

Standard range

MULTI-BLADED REAMERS AND COUNTERSINKING TOOLS

YOUR PARTNER FOR REAMING AND COUNTERSINKING

History, tradition and progress

Founded in 1906 by August Beck in Winterlingen, today the company is the specialist for the fine machining of bores using multi-bladed reamers. With this portfolio, its many years of experience and its special know-how, BECK has made a name for itself worldwide in the automotive and machine engineering sector as well as in trade. Today BECK stands for the high quality and the precision of its products. BECK offers its customers a broad product range for reliable and cost-effective machining processes.

The offering ranges from standardised reamers as per DIN/ISO made of HSS-E or carbide metal, through high-performance reamers made of solid carbide or with brazed blades, right up to modern replaceable head systems. Countersinking and boring tools complete the range. This ensures that the right tool concept is always found to meet the requirements of the workpiece material to be machined, the demanded tolerance and the planned manufacturing volume.

All high-quality products are of course "Made in Germany" and always available from stock. Even intermediate sizes and special fits can be supplied at short notice if required. In addition, BECK also offers numerous individual custom tools. New developments constantly complement the product range in order to meet the growing demands of modern manufacturing.

High-performance, innovative products paired with high availability and absolute customer orientation make BECK the dependable partner for reaming and countersinking.

Customer Focus

Customers' expectations of BECK and their products are very high all over the world. Active communication with customers makes it possible to understand their needs and demands. This understanding creates the basis for responsible action in line with the challenges presented to all employees. High-quality products and services are the result of this process. Dependability and perseverance are the guiding principles that characterise all of BECK's activities.

Stability on the market and expansion of the market shares

BECK customers expect modern and future-oriented products and services. It is therefore BECK's declared goal to maintain and further expand this position in a constantly changing market environment through innovative products and solutions. As specialists for fixed tools, BECK also aims to develop into new areas where the company can gain a leading position on the market thanks to their competence, high manufacturing depth and experience.

Innovation as the foundation for a successful company

Innovation is the main driver behind the company's success in all of its areas of expertise. For this reason, freedom of thought and action are given free rein every day. This results in new, positive developments for the technology sector and the company as a whole.





You can find out more on our website
www.beck.mapal.com



Partnerships within the MAPAL Group

For a professional and dependable partnership with the trade, BECK is part of an association of three strong brands from leading, internationally renowned tool manufacturers. Within the MAPAL Group, it is a matter of conviction and an objective to support and develop processes, products and services internally on the basis of partnership. BECK profits from this cooperation. Through its active involvement, BECK contributes to the overall success of the MAPAL Group.

Precise and high-quality products

BECK's customers rely on the guaranteed precision of all BECK products. For this reason, quality and precision are a constant obligation for BECK and part of the vision for all employees. The company goals as well as standards regarding abilities and activities reflect this vision and are practised every day at BECK.

Employees are the guarantee of success

Ongoing intensive contact with the customers makes it possible to assess and actively fulfil the expectations of BECK and its products. The experience gathered in the process provides a clear view of the chances and opportunities here. The compilation and implementation of this information to the benefit of the company and to the satisfaction of BECK's customers is particularly important. This is only possible thanks to a high degree of competence, enthusiasm and commitment on the part of all BECK employees.





CONTENTS

01 Introduction

Product overview	6
Special solutions	8
Reconditioning	10
Innovations and highlights	12
Selection of multi-bladed reamers	14
Selection system	16

02 High-performance reamers

Product overview: high-performance reamers	24
HNC reamers	26
FXR reamers	66
Drill-Reamers	70
XR replaceable head reamers	78

03 Machine reamers

Product overview: machine reamers	140
Machine reamers without internal cooling	142
Hand reamers	220
Shell reamers	232

04 Countersinking and boring tools

Product overview: countersinking and boring tools	246
Countersink	248
Counterbores	267
Boring tools	278

05 Technical appendix

Technical appendix	300
--------------------------	-----



PRODUCT OVERVIEW



High-performance reamers

- 1 HNC reamers (page 26)
- 2 FXR reamers (page 66)
- 3 Drill-Reamers (page 70)
- 4 XR replaceable head reamers (page 78)

Machine reamers

- 5 Machine reamers without internal cooling (page 142)
- 6 Hand reamers (page 220)
- 7 Shell reamers (page 232)



Countersinking and boring tools

- 8 Countersink (page 248)
- 9 Counterbores (page 267)
- 10 Boring tools (page 278)

SPECIAL SOLUTIONS

Multi-bladed reamer

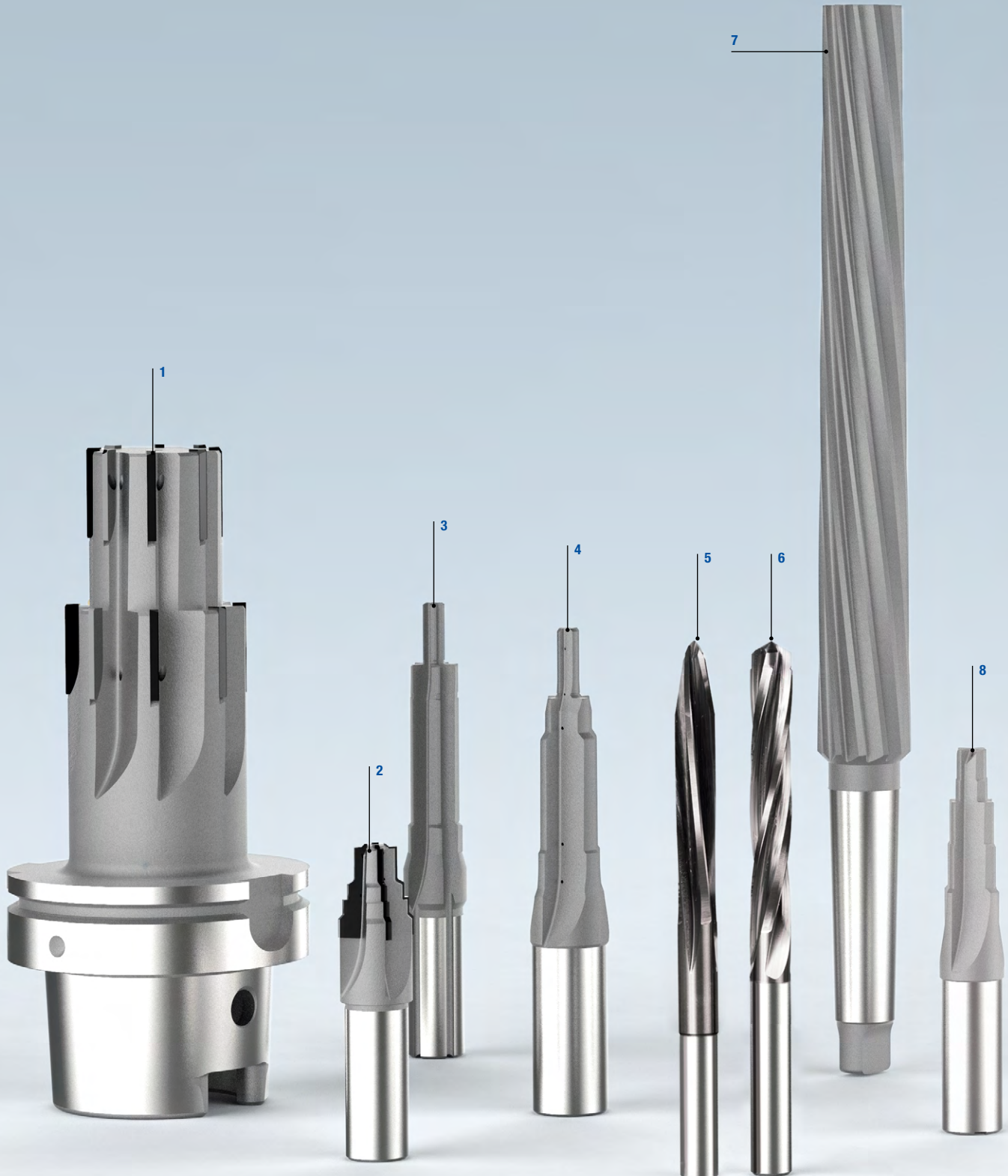

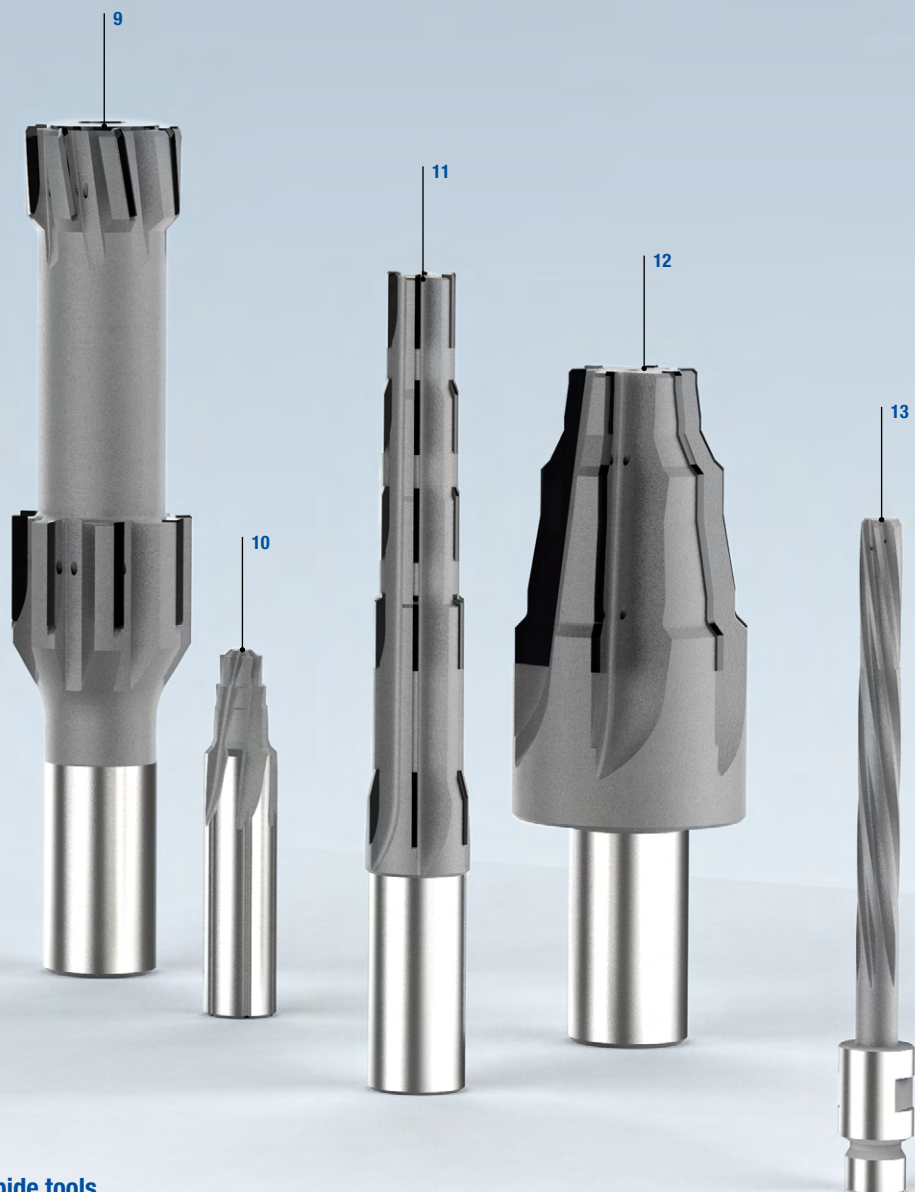

Special solutions – solid carbide tools

- 1 Two-stage custom tool with brazed blades for machining a hydraulic housing made of EN-GJS-500-7
- 2 Tipped multi-stepped custom tool with chamfer and radius machining of a steel cylinder holder
- 3 Coated solid carbide step reamer for machining the injector bore in a cylinder head
- 4 Coated solid carbide step reamer for fine machining the contour of the spark plug bore in EN-GJL-250
- 5 Hand drill made of solid carbide for machining CFRP workpiece materials
- 6 Boring reamer made of solid carbide for machining multilayer composite workpiece materials
- 7 HSS machine taper reamer with MK shank
- 8 Solid carbide step reamer with VA geometry for machining a stainless steel valve block
- 9 Two-stage custom reamer with brazed cermet blades with combined straight and left-hand fluted design
- 10 Coated multi-stage solid carbide reamer with internal cooling on the shank for machining a rail
- 11 Step reamer with brazed half-round embedded cermet blades for machining a steel nozzle holder
- 12 Coated carbide-tipped form reamer for machining special turned parts
- 13 High-performance reamer with blunt brazed solid carbide head with custom connection for aerospace for machining a titanium, aluminium and high-alloy steel rivet hole combination

WORLDWIDE RECONDITIONING SERVICE

It doesn't matter where in the world you're manufacturing your products: You can be sure that you will be able to take advantage of our on-site services for reconditioning your tools to original BECK quality.



**CONSISTENT
QUALITY STANDARDS
WORLDWIDE**



**MANUFACTURING AND RECONDITIONING TOOLS
FROM A SINGLE SOURCE**



**RECONDITIONING AVAILABLE WORLDWIDE WITH
IDENTICAL
MACHINES AND SOFTWARE**



**CONTACT PARTNERS
STATIONED IN EVERY COUNTRY**



SERVICE ON SITE
EVEN FOR COMPLEX TOOL SYSTEMS



EASY, QUICK AND TIMELY
PROCESSING



HIGH-QUALITY
EQUIPMENT, GRINDING WHEELS, ETC.



QUALIFIED, SPECIALLY
TRAINED SERVICE PERSONNEL
WORLDWIDE

INNOVATIONS | HIGHLIGHTS

HNC-Plus

Cost-efficient and productive

New carbide substrates specially adapted to machining, in combination with new coatings ensure better tool life. Thanks to a new circular ground chamfer the reamers are even better guided in the bore - roundness and cylinder shapes are improved even further.

1 High-performance coating

- For the processing of **P M K N S H**

2 Patented arc land chamfer

- For up to 30 % better roundness and cylinder shape

3 Prime number division

- Less vibrations, better surface finish, smoother running and longer tool life

4 Innovative coolant supplies

- Optimum cooling lubricant supply for blind and through bores

Universally applicable

- One design for machining blind and through bores to reduce storage costs

Short design

- for more stability and higher feeds

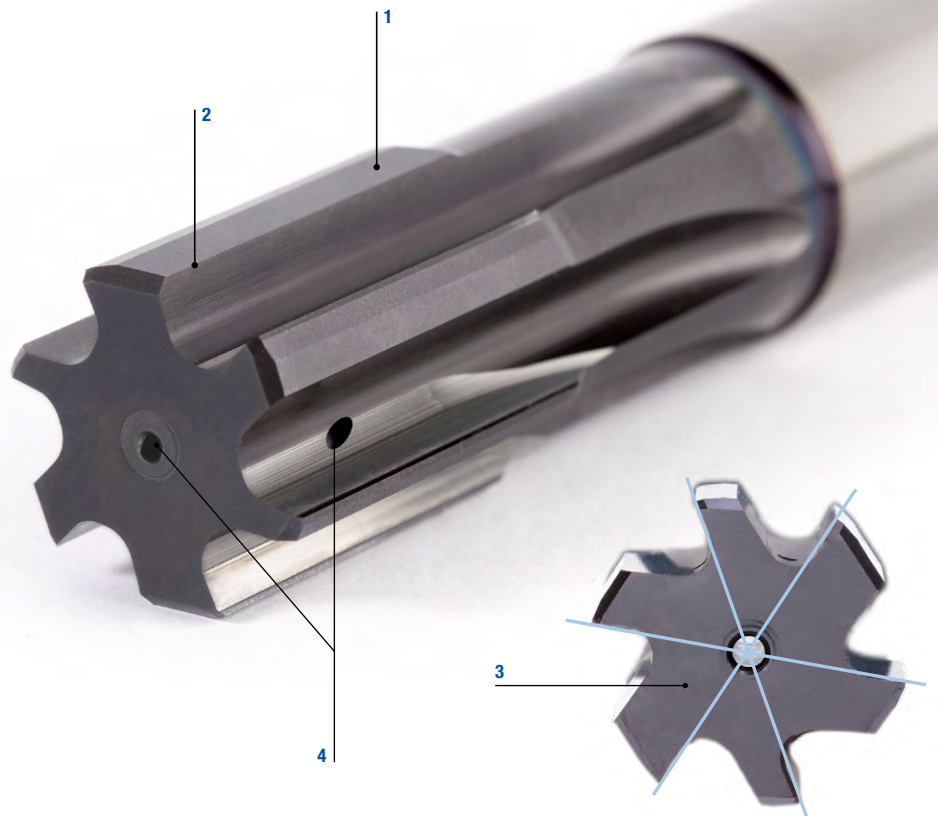

Features

- One reamer for through bore and blind bore
- Up to 100 % increase in tool life
- Low storage costs, as universally applicable
- Short design increases stability and conserves carbide resources
- In the diameter range from 3.701 to 20.200 mm
- Perfectly matched to almost all materials
- Patented circular ground chamfer

Achieved tool life [%]

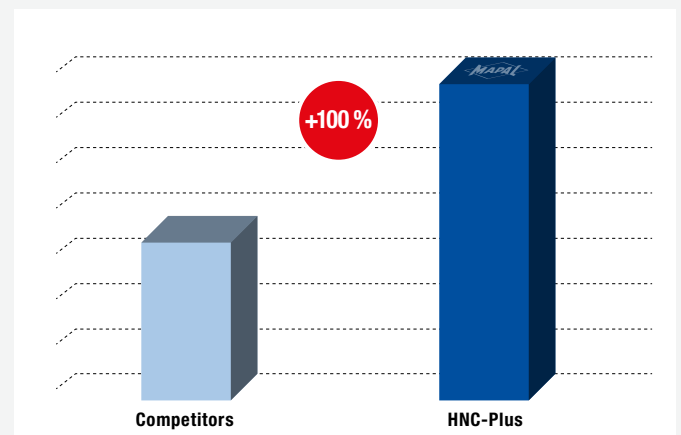

FixReam 700

Reconditioning enables the cost per part to be considerably reduced

The FixReam 700 was developed to increase economic efficiency through effective reconditioning. Thanks to an expansion screw, the multi-bladed reamer can be expanded in diameter before regrinding. As a result, all functional surfaces can be reground, both on the lead as well as on the tool diameter. This allows the reamer to be reused up to 9 times.

1 30% better roundness and cylindrical form

- Thanks to patented geometry

2 Optimal chip shape

- New, innovative leads enable better chip shape

3 Up to 9 uses

- Possible through expansion screw for compensation before regrinding

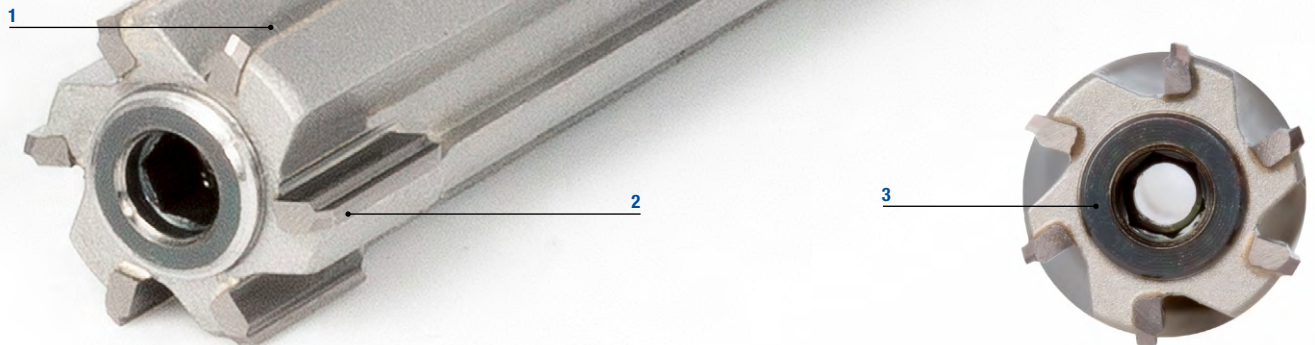

Features

Configurable features:

- \emptyset area: 9.900 - 32.200 mm
- Bore diameter: Tolerance \geq IT6
- Tool diameter: Tolerance \geq 3 μ m in increments of 0.001 mm
- Further carbide-coated and cermet-coated variants to follow in Q2 2024

Dimensions:

- Available as a short and long design
- For through bores and blind bores
- Preferred series available from stock in H7: 10.000 - 32.000 mm

Achieved tool life [%]

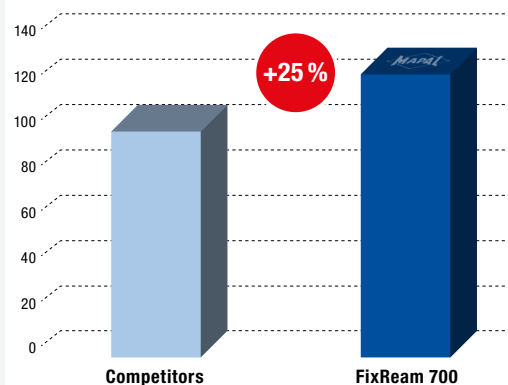











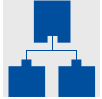
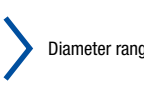

Workpiece material: 42CrMoS4
Machining length: 45.00 mm
Nominal \emptyset : 12.00 mm
n: 3448 rpm
vf: 3448 mm/min
vc: 130 m/min
z: 6

SELECTION OF MULTI-BLADED REAMERS

Step by step to the right reamer

This selection aid guides you step by step to the right reamer.

1	Application	Select your application.	 Reaming	 Countersinking
2	Product category	Choose a product category.	 Basic LINE	Basic Line: Universal tools, broad field of application, low procurement costs
3	Design	Select your preferred design (monolithic or modular).	 Monolithic	 Modular connection
4	Bore features	Check that the geometric features meet your requirements. Select the diameter range and the required tolerance.	 Diameter range	 $\leq IT7$ $\geq IT7$ Achievable bore tolerance
5	Material suitability	Identify your workpiece material as per BECK machining groups.	 P Steel	 M Stainless steel
6	Type of bore	Check the requirements that are placed on your tool by the type of bore.	 Through hole	 Blind bore
7	Product	Select your reamer. Products of the preferred series are available from stock and at short notice, while products with configurable features can be freely configured within predefined limits.	 Free configuration	 CONFIG Product with configurable features

16 STANDARD RANGE | Introduction

Reaming (1/2)

Product category	Design	Bore features		Series
		Diameter (Preferred series available from stock)	Tolerance	
Performance LINE	Monolithic	3.000 - 20.000*	≥ IT6	HNC
		3.970 - 20.000*		HNC-Plus
		3.000 - 20.000*		HNC-Speed

HNC reamers

Solid carbide reamer for a wide range of applications. Depending on the diameter, the high-performance reamers HNC have between four and eight cutting edges with internal cooling and achieve correspondingly high feed rates.

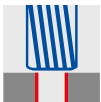

Boring



Performance Line:
High-performance tools, broad field of application,
high productivity in series production



Expert Line:
Specialist tools for selected applications,
maximum precision and productivity



Cast iron



Non-ferrous metals
and plastics

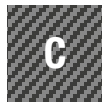

Composite
materials



Super alloy
and titanium



Hardened steel
and cast steel



Interrupted cut



Preferred series
available from stock

STANDARD RANGE | Introduction 17

Step 1:
Application

Step 2:
Product category

Step 3:
Design

Step 4:
Bore features

Step 5:
Material suitability

Step 6:
Type of bore

Material suitability															Type of bore			Product						
P						M	K					N	C			S	H		CONFIG	Configurable diameter range	Page			
1	2	3.1	3.2	3.3	4	5	6	1-3	1	2.1	2.2	2.3	3	1-2	3	1.1	1.2	1.3				1-5	1	2
																							✓	32
																							✓	26
																							✓	34
																							✓	64





5

6

7



Reaming (1/2)

Product category	De-sign	Bore features		Series			
		Diameter (Preferred series available from stock)	Tolerance		Series		
Performance LINE		3.970 - 20.000*	≥ IT6	HNC reamers	 <p>Solid carbide reamer for a wide range of applications. Depending on the diameter, the high-performance reamers HNC have between four and eight cutting edges with internal cooling and achieve correspondingly high feed rates.</p>	HNC-Plus	
		3.000 - 20.000*				HNC	
		3.000 - 20.000*				HNC-Speed	
		3.000 - 20.000*				HNC-Short	
		10.000 - 32.000	≥ IT6	FixReam 700	 <p>The FixReam 700 increases efficiency thanks to an expansion screw that expands the diameter before regrinding and enables reuse up to 9 times.</p>	FXR700	
		4.000 - 16.000	≥ IT7	Drill-Reamer	 <p>The Drill-Reamer allows the combined processing of boring and reaming in a single step, resulting in a faster and more efficient working method and significantly reduced machining times.</p>	Drill-Reamer-Pyramid	
		4.000 - 16.000				Drill-Reamer	
			8.000 - 40.000	≥ IT6	XR replaceable head reamers	 <p>High-performance reamer as replaceable head system in solid carbide and tipped design from diameter ø 8.00 mm (DL) and ø 10.00 mm (GL).</p>	XR 06 Solid carbide
			8.000 - 40.000				XR 01 Tipped

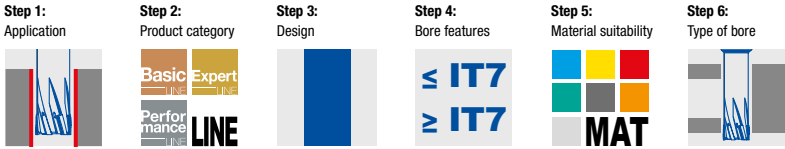

	Material suitability															Type of bore			Product								
	P						M	K					N		C			S	H			Configurable diameter range	Page				
	1	2	3.1	3.2	3.3	4	5	6	1-3	1	2.1	2.2	2.3	3	1-2	3	1.1	1.2	1.3	1-5				1	2		
	■	■	■	■	■	■	■	■	■	■	■	■	■	■						■	■	■	■	■		✓	26
					■		■	■	■	■	■	■	■	■		■	■	■	■				■	■	■	✓	32
	■	■	■	■	■		■	■	■	■	■	■	■										■	■		✓	34
	■	■	■	■	■	■	■	■	■	■	■	■	■										■	■		✓	64
	■	■	■	■	■			■	■	■	■	■	■										■	■		✓	66
	■	■	■	■	■		■	■	■	■	■	■	■										■	■		✓	70
	■	■	■	■	■		■	■	■	■	■	■	■										■	■		✓	72
	■	■	■	■	■	■	■	■	■	■	■	■	■	■								■	■	■	■	✓	78
	■	■	■	■	■		■	■	■	■	■	■	■	■									■	■	■	✓	88



Reaming (2/2)

Product category	Design	Bore features		Series				
		Diameter (Preferred series available from stock)	Tolerance			Series		
Basic LINE	[Highly suitable]	0.600 - 30.200*	≥ IT6	Machine reamers without internal cooling		<p>BECK offers cost-effective DIN reamers in carbide and HSS variants with high stock availability and quality, particularly suitable for applications with small to medium lot sizes or older machines without internal coolant supply.</p>	NC machine reamers in accordance with DIN	
		1.000 - 40.000*					Machine reamers in accordance with DIN with carbide blades	
		1.000 - 20.000					NC machine reamers in accordance with DIN made of HSS-E	
		1.000 - 50.000					Machine reamers in accordance with DIN made of HSS-E	
		8.000 - 40.000					Reamers in accordance with DIN and WN with solid carbide blades	
		1.000 - 40.000					Special reamers in accordance with DIN and WN made of HSS-E	
	[Suitable in some situations]	1.000 - 60.000*	≥ IT6	Hand reamers		<p>BECK manual and taper reamers are high-quality tools, adapted for hard-to-reach bores or tapered transitions, and offer high surface finish and performance despite manual use.</p>	Hand reamers	
		6.400- 95.000		Quick adjustment reamer		<p>Features a wide adjustment range. Especially suitable for repair work.</p>	Quick adjustment reamer	
	[Suitable in some situations]	[Highly suitable]	25.000 - 100.000*	≥ IT6	Shell reamers		<p>Shell reamers in accordance with DIN and associated tool holders in accordance with DIN.</p>	Shell reamers

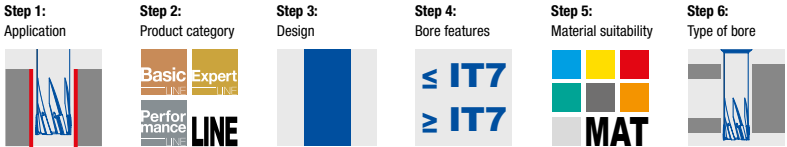

	Material suitability															Type of bore			Product						
	P						M	K					N		C			S	H			Configurable diameter range	Page		
	1	2	3.1	3.2	3.3	4	5	6	1-3	1	2.1	2.2	2.3	3	1-2	3	1.1	1.2	1.3	1-5				1	2
	■	■	■	■	■				■	■	■	■	■	■										✓	142
	■	■	■	■	■				■	■	■	■	■	■										✓	152
	■	■	■	■	■				■	■	■	■	■	■										✓	170
	■	■	■	■	■				■	■	■	■	■	■										✓	176
	■	■	■	■	■				■	■	■	■	■	■										-	216
	■	■	■	■	■				■	■	■	■	■	■										✓	211
	■	■	■	■	■				■	■				■										✓	220
	■	■	■	■	■				■	■				■										-	226
	■	■	■	■	■				■	■	■	■	■	■										✓	232



Countersinking

Product category	De-sign	Bore features		Series		
		Diameter (Preferred series available from stock)	Tolerance		Series	
Basic LINE		4.300 - 31.000*		 Countersinks 90° with extremely unequal cutting edge spacing. Precision design made of HSS and solid carbide with special coating.	EUC-Speed	
		4.300 - 100.000			 With even cutting edge spacing. Precision design made of HSS and solid carbide with various coatings.	Countersinks 90° in accordance with DIN and factory standard
		6.000 - 80.000*			 With even cutting edge spacing. Precision design made of HSS and HSS with TiN coating.	Countersinks 60° in accordance with DIN and factory standard
		6.000 - 63.000*		 Counterbores With solid and replaceable pilots. Designs made of HSS and HSS with TiN coating.	Counterbores in accordance with DIN and factory standard	

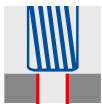

Boring

Product category	De-sign	Bore features		Series	
		Diameter (Preferred series available from stock)	Tolerance		Series
Basic LINE		4.800 - 100.000*	IT8	 Boring tools HSS boring tools allow precise boring before reaming and avoid the need for expensive intermediate diameters thanks to their adaptable design.	Boring tools made of HSS

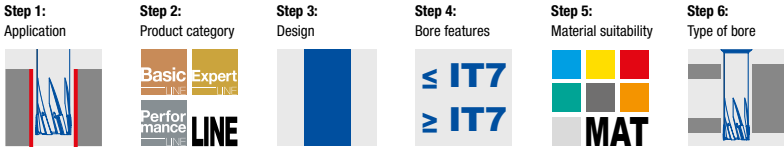

	Material suitability																Type of bore			Product					
	P						M	K					N		C			S	H			Configurable diameter range	Page		
	1	2	3.1	3.2	3.3	4	5	6	1-3	1	2.1	2.2	2.3	3	1-2	3	1.1	1.2	1.3	1-5				1	2
	■	■	■	■	■	■	■	■	■	■	■	■	■	■	■	■	■	■	■	■	■	■	■	-	248
	■	■	■	■	■	■	■	■	■	■	■	■	■	■	■				■	■			-	252	
	■	■	■	■	■	■	■	■	■	■	■	■	■	■	■				■	■			-	262	
	■	■	■	■	■	■	■	■	■	■	■	■	■	■	■				■	■			-	267	

	Material suitability																Type of bore			Product				
	P						M	K					N		C			S	H			Configurable diameter range	Page	
	1	2	3.1	3.2	3.3	4	5	6	1-3	1	2.1	2.2	2.3	3	1-2	3	1.1	1.2	1.3	1-5				1
	■	■	■	■	■				■	■	■	■	■	■	■				■	■			-	278



HIGH-PERFORMANCE REAMERS

Introduction

Product overview	24
------------------------	----

High-performance reamers

HNC-Plus	26
HNC	32
HNC-Short	64
FXR reamers	66
Drill-Reamer	70
XR replaceable head reamers	78

Technical appendix

Cutting data recommendations	120
------------------------------------	-----

PRODUCT OVERVIEW

High-performance reamers, replaceable head reamers and drill reamers

Drastically reduced machining times are possible using fixed multi-bladed reamers. The multiple blades permit a higher feed rate, which ultimately reduces machining times. Due to specifically developed systems and the latest manufacturing technology, BECK guarantees the highest levels of accuracy on these tools.

The product portfolio offers a wide variety that will satisfy all the requirements of the machining task: from monoblock designs to modern replaceable head systems. Drill reamers allow the cost-efficient production of precision fit bores with just one tool, which can significantly reduce both productive and non-productive times.



High-performance reamers



HNC-Plus

With the powerful HNC-Plus high-performance reamer for machining almost all workpiece materials, both through bores and blind bores can be machined with the same reamer.

Ø area: 3.970 - 20.000*



HNC

High-performance reamers made of solid carbide, spiral fluted with internal cooling. Preferred series with tolerance H7 and +0.004 mm, configurable series for intermediate diameters and special tolerances.

Ø area: 3.000 - 20.000*





HNC-Short

Extra short high-performance reamer made of solid carbide that is specially designed for usage on automated lathes.

Ø area: 3.000 - 20.000*

* The diameter range can vary, depending on the series.



	Drill reamers	Replaceable head reamers
		
<p>FixReam 700</p> <p>The FixReam 700 was developed to increase economic efficiency through efficient reconditioning. Thanks to an expansion screw, the diameter of the multi-bladed reamer can be extended prior to regrinding. This makes it possible to regrind all functional surfaces, both on the lead, and also on the tool diameter. As a result, the reamer can be reused up to 9 times.</p> <p>Ø area: 10.000 - 32.000</p>	<p>Drill-Reamer</p> <p>Drilling and reaming is realised in one work step thanks to the Drill-Reamer. In this way bores can be machined faster and more efficiently and the productive and non-productive times significantly reduced. Two drill cutting edges on the coated tool initially undertake the bore machining into the solid. Four slightly axially offset reaming cutting edges provide the fine machining and safeguard the required surface finishes, the dimensional accuracy as well as the roundness in reaming quality.</p> <p>Ø area: 4.000 - 16.000</p>	<p>XR replaceable head reamers</p> <p>To counter rising tool costs, BECK has modular tool systems in its product range that offer a particularly high degree of flexibility as the tool holders can be fitted with different reaming elements via defined connections. Short tool change times, generally without re-measuring, make this type of tools attractive for medium and large lot sizes as the change can be carried out directly at the machine.</p> <p>Ø area: 8.000 - 40.000</p>
<p>Page 66</p>	<p>Page 70</p>	<p>Page 78</p>

HNC-Plus PK I B043565

Fixed design, straight fluted, for blind and through bores, internal coolant supply

Design:

Diameter: 3.701 - 20.200 mm
 Cutting direction: Right-hand cutting
 Cutting material: Solid carbide, BPK-coated (HP900)
 Groove direction: Straight fluted
 Geometry: HPC, EU spacing

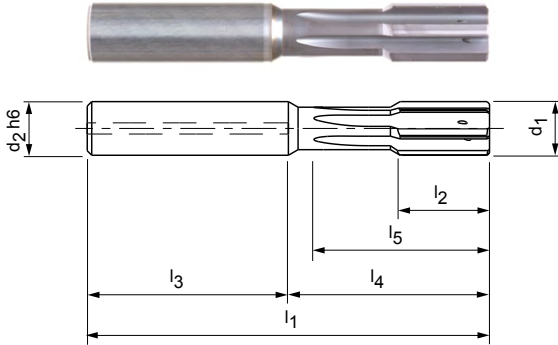

Preferred series available from stock in H7 | +0.005

Dimensions								z	Order no.
d ₁	Tolerance	d ₂ h ₆	l ₁	l ₂	l ₃	l ₄	l ₅		
3,970	+0,005	4	50	12	28	22	19	4	31174797
3,980	+0,005	4	50	12	28	22	19	4	31174798
3,990	+0,005	4	50	12	28	22	19	4	31174799
4,000	H7	4	50	12	28	22	19	4	31142699
4,010	+0,005	4	50	12	28	22	19	4	31174800
4,020	+0,005	4	50	12	28	22	19	4	31174801
4,030	+0,005	4	50	12	28	22	19	4	31174802
4,970	+0,005	4	50	12	28	22	19	4	31174803
4,980	+0,005	4	50	12	28	22	19	4	31174804
4,990	+0,005	4	50	12	28	22	19	4	31174805
5,000	H7	4	50	12	28	22	19	4	31142761
5,010	+0,005	4	50	12	28	22	19	4	31174806
5,020	+0,005	4	50	12	28	22	19	4	31174807
5,030	+0,005	4	50	12	28	22	19	4	31174808
5,970	+0,005	6	64	12	36	28	25	6	31174809
5,980	+0,005	6	64	12	36	28	25	6	31174810
5,990	+0,005	6	64	12	36	28	25	6	31174811
6,000	H7	6	64	12	36	28	25	6	31142763
6,010	+0,005	6	64	12	36	28	25	6	31174812
6,020	+0,005	6	64	12	36	28	25	6	31174813
6,030	+0,005	6	64	12	36	28	25	6	31174814
7,000	H7	6	70	16	36	34	31	6	31142765
7,970	+0,005	8	75	16	36	39	36	6	31174815
7,980	+0,005	8	75	16	36	39	36	6	31174816
7,990	+0,005	8	75	16	36	39	36	6	31174817
8,000	H7	8	75	16	36	39	36	6	31142767
8,010	+0,005	8	75	16	36	39	36	6	31174818
8,020	+0,005	8	75	16	36	39	36	6	31174819
8,030	+0,005	8	75	16	36	39	36	6	31174820
9,000	H7	8	80	20	36	44	41	6	31142769
9,970	+0,005	10	80	20	40	40	37	6	31174821
9,980	+0,005	10	80	20	40	40	37	6	31174822
9,990	+0,005	10	80	20	40	40	37	6	31174823
10,000	H7	10	80	20	40	40	37	6	31142771
10,010	+0,005	10	80	20	40	40	37	6	31174824

HNC-Plus PK I B043565, fixed design, straight fluted, for blind and through bores

Dimensions								z	Order no.
d ₁	Tolerance	d ₂ h6	l ₁	l ₃	l ₃	l ₄	l ₅		
10,020	+0,005	10	80	20	40	40	37	6	31174825
10,030	+0,005	10	80	20	40	40	37	6	31174826
11,000	H7	10	85	20	40	45	42	6	31142773
11,970	+0,005	12	90	20	45	45	42	6	31174827
11,980	+0,005	12	90	20	45	45	42	6	31174828
11,990	+0,005	12	90	20	45	45	42	6	31174829
12,000	H7	12	90	20	45	45	42	6	31142775
12,010	+0,005	12	90	20	45	45	42	6	31174830
12,020	+0,005	12	90	20	45	45	42	6	31174831
12,030	+0,005	12	90	20	45	45	42	6	31174832
13,000	H7	12	90	22	45	45	42	6	31142776
14,000	H7	14	95	22	45	50	47	6	31142777
15,000	H7	14	100	22	45	55	52	6	31142778
16,000	H7	16	105	25	48	57	54	6	31142779
17,000	H7	16	110	25	48	62	59	6	31142780
18,000	H7	18	110	25	48	62	59	6	31142781
19,000	H7	18	110	25	48	62	59	6	31142782
20,000	H7	20	115	25	50	65	62	6	31142783

Configurable features



Bore diameter tolerance ≥ IT6:
- Diameter in increments of 0.001 mm
freely selectable



Specification:
B043565[Diameter][Tolerance]

G variant (see page 303):
- Diameter in increments of 0.001 mm
freely selectable
- Can be ordered from tolerances ≥ 5 μm

G variant specification:
B043565[Diameter][Tolerance]

IT8 tolerance example:
B043565-Ø11.530H8

Bore diameter d₁ = 11.530 H8

G variant example:
B043565-Ø11.530+5

Special tool diameter d₁ = 11.530 +5 μm

Dimensions of configurable series IT6

d ₁	d ₂ h6	l ₁	l ₂	l ₃	l ₄	l ₅	z
3,701 - 5,200	4	50	12	28	22	19	4
5,201 - 5,700	6	64	12	36	28	25	4
5,701 - 6,200	6	64	12	36	28	25	6
6,201 - 7,700	6	70	16	36	34	31	6
7,701 - 8,200	8	75	16	36	39	36	6
8,201 - 8,700	8	75	20	36	39	36	6
8,701 - 9,700	8	80	20	36	44	41	6
9,701 - 10,700	10	80	20	40	40	37	6
10,701 - 11,700	10	85	20	40	45	42	6
11,701 - 12,200	12	90	20	45	45	42	6
12,201 - 13,200	12	90	22	45	45	42	6
13,201 - 14,200	14	95	22	45	50	47	6
14,201 - 15,200	14	100	22	45	55	52	6
15,201 - 16,200	16	105	25	48	57	54	6
16,201 - 17,200	16	110	25	48	62	59	6
17,201 - 19,200	18	110	25	48	62	59	6
19,201 - 20,200	20	115	25	50	65	62	6

Dimensions in mm.

For cutting data recommendations, see end of chapter.

HNC-Plus MS | B043575

Fixed design, straight fluted, for blind and through bores, internal coolant supply

Design:

Diameter: 3.701 - 20.200 mm
 Cutting direction: Right-hand cutting
 Cutting material: Solid carbide, BMS-coated (HP900)
 Groove direction: Straight fluted
 Geometry: HPC, EU spacing

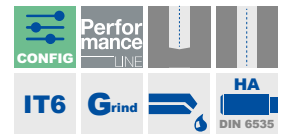
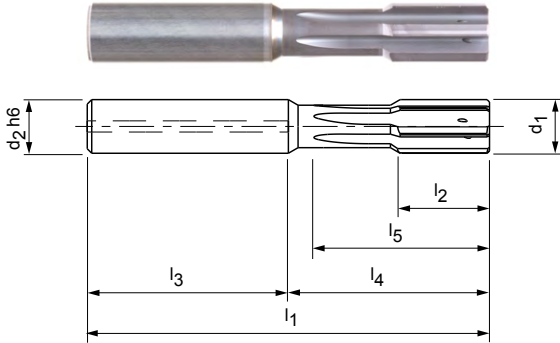

Configurable features



Bore diameter tolerance \geq IT6:
 - Diameter in increments of 0.001 mm freely selectable

Specification:
 B043575[**Diameter**][**Tolerance**]

G variant (see page 303):
 - Diameter in increments of 0.001 mm freely selectable
 - Can be ordered from tolerances $\geq 5 \mu\text{m}$

G variant specification:
 B043575[**Diameter**][**Tolerance**]

IT8 tolerance example:
 B043575- **\varnothing 11.530H8**

Bore diameter $d_1 = 11.530 \text{ H8}$

G variant example:
 B043575- **\varnothing 11.530+5**

Special tool diameter $d_1 = 11.530 +5 \mu\text{m}$

Dimensions of configurable series IT6

d_1	d_2 h6	l_1	l_2	l_3	l_4	l_5	z
3,701 - 5,200	4	50	12	28	22	19	4
5,201 - 5,700	6	64	12	36	28	25	4
5,701 - 6,200	6	64	12	36	28	25	6
6,201 - 7,700	6	70	16	36	34	31	6
7,701 - 8,200	8	75	16	36	39	36	6
8,201 - 8,700	8	75	20	36	39	36	6
8,701 - 9,700	8	80	20	36	44	41	6
9,701 - 10,700	10	80	20	40	40	37	6
10,701 - 11,700	10	85	20	40	45	42	6
11,701 - 12,200	12	90	20	45	45	42	6
12,201 - 13,200	12	90	22	45	45	42	6
13,201 - 14,200	14	95	22	45	50	47	6
14,201 - 15,200	14	100	22	45	55	52	6
15,201 - 16,200	16	105	25	48	57	54	6
16,201 - 17,200	16	110	25	48	62	59	6
17,201 - 19,200	18	110	25	48	62	59	6
19,201 - 20,200	20	115	25	50	65	62	6

HNC-Plus AL | B043555

Fixed design, straight fluted, for blind and through bores, internal coolant supply

Design:

Diameter: 3.701 - 20.200 mm
 Cutting direction: Right-hand cutting
 Cutting material: Solid carbide, BAL-coated (HP622)
 Groove direction: Straight fluted
 Geometry: HPC, EU spacing

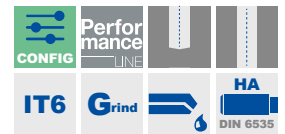
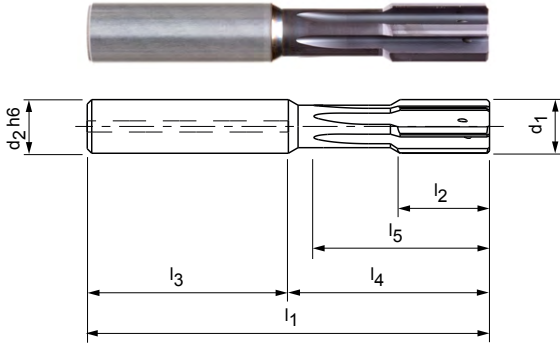

Configurable features



Bore diameter tolerance \geq IT6:
 - Diameter in increments of 0.001 mm freely selectable

Specification:
 B043555[Diameter][Tolerance]

G variant (see page 303):
 - Diameter in increments of 0.001 mm freely selectable
 - Can be ordered from tolerances $\geq 4 \mu\text{m}$

G variant specification:
 B043555[Diameter][Tolerance]

IT8 tolerance example:
 B043555- \varnothing 11.530H8

Bore diameter $d_1 = 11.530 \text{ H8}$

G variant example:
 B043555- \varnothing 11.530+4

Special tool diameter $d_1 = 11.530 +4 \mu\text{m}$

Dimensions of configurable series IT6

d_1	$d_2 h_6$	l_1	l_2	l_3	l_4	l_5	z
3,701 - 5,200	4	50	12	28	22	19	4
5,201 - 5,700	6	64	12	36	28	25	4
5,701 - 6,200	6	64	12	36	28	25	6
6,201 - 7,700	6	70	16	36	34	31	6
7,701 - 8,200	8	75	16	36	39	36	6
8,201 - 8,700	8	75	20	36	39	36	6
8,701 - 9,700	8	80	20	36	44	41	6
9,701 - 10,700	10	80	20	40	40	37	6
10,701 - 11,700	10	85	20	40	45	42	6
11,701 - 12,200	12	90	20	45	45	42	6
12,201 - 13,200	12	90	22	45	45	42	6
13,201 - 14,200	14	95	22	45	50	47	6
14,201 - 15,200	14	100	22	45	55	52	6
15,201 - 16,200	16	105	25	48	57	54	6
16,201 - 17,200	16	110	25	48	62	59	6
17,201 - 19,200	18	110	25	48	62	59	6
19,201 - 20,200	20	115	25	50	65	62	6

Dimensions in mm.

For cutting data recommendations, see end of chapter.

HNC-Plus H I B043585

Fixed design, straight fluted, for blind and through bores, internal coolant supply

Design:

Diameter: 3.701 - 20.200 mm
 Cutting direction: Right-hand cutting
 Cutting material: Solid carbide, BHT-coated (HP141)
 Groove direction: Straight fluted
 Geometry: HPC, EU spacing

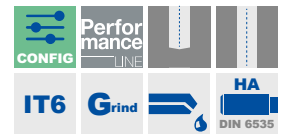
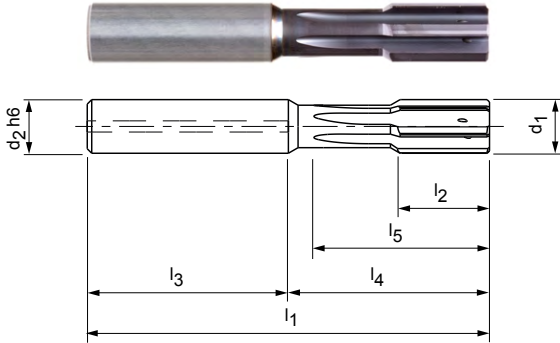

Configurable features



Bore diameter tolerance \geq IT6:
 - Diameter in increments of 0.001 mm freely selectable

Specification:
 B043585[Diameter][Tolerance]

G variant (see page 303):
 - Diameter in increments of 0.001 mm freely selectable
 - Can be ordered from tolerances $\geq 5 \mu\text{m}$

G variant specification:
 B043585[Diameter][Tolerance]

IT8 tolerance example:
 B043585- \emptyset 11.530H8

Bore diameter $d_1 = 11.530 \text{ H8}$

G variant example:
 B043585- \emptyset 11.530+5

Special tool diameter $d_1 = 11.530 +5 \mu\text{m}$

Dimensions of configurable series IT6

d_1	d_2h6	l_1	l_2	l_3	l_4	l_5	z
3,701 - 5,200	4	50	12	28	22	19	4
5,201 - 5,700	6	64	12	36	28	25	4
5,701 - 6,200	6	64	12	36	28	25	6
6,201 - 7,700	6	70	16	36	34	31	6
7,701 - 8,200	8	75	16	36	39	36	6
8,201 - 8,700	8	75	20	36	39	36	6
8,701 - 9,700	8	80	20	36	44	41	6
9,701 - 10,700	10	80	20	40	40	37	6
10,701 - 11,700	10	85	20	40	45	42	6
11,701 - 12,200	12	90	20	45	45	42	6
12,201 - 13,200	12	90	22	45	45	42	6
13,201 - 14,200	14	95	22	45	50	47	6
14,201 - 15,200	14	100	22	45	55	52	6
15,201 - 16,200	16	105	25	48	57	54	6
16,201 - 17,200	16	110	25	48	62	59	6
17,201 - 19,200	18	110	25	48	62	59	6
19,201 - 20,200	20	115	25	50	65	62	6

Dimensions in mm.

For cutting data recommendations, see end of chapter.



HNC I B040260

Fixed design for through bore, internal coolant supply

Design:

Diameter: 2.800 - 20.200 mm
 Cutting direction: Right-hand cutting
 Cutting material: Solid carbide, uncoated (HU612)
 Groove direction: Spiral fluted
 Geometry: HPC, EU spacing

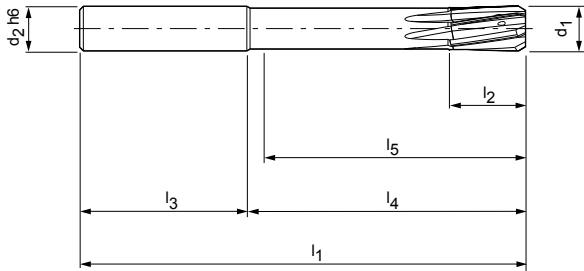

Preferred series available from stock in H7 | +0.004

Dimensions								z	Order no.
d ₁	Tolerance	d ₂ h6	l ₁	l ₂	l ₃	l ₄	l ₅		
3,000	H7	4	65	12	28	37	34	4	30402429
3,200	H7	4	65	12	28	37	34	4	30402431
3,500	H7	4	65	12	28	37	34	4	30402433
3,970	+0,004	6	75	12	36	39	34	4	30131192
3,980	+0,004	6	75	12	36	39	34	4	30131194
3,990	+0,004	6	75	12	36	39	34	4	30131196
4,000	H7	6	75	12	36	39	34	4	30131198
4,010	+0,004	6	75	12	36	39	34	4	30131200
4,020	+0,004	6	75	12	36	39	34	4	30131202
4,030	+0,004	6	75	12	36	39	34	4	30131204
4,500	H7	6	75	12	36	39	34	4	30131206
4,970	+0,004	6	75	12	36	39	35	4	30131208
4,980	+0,004	6	75	12	36	39	35	4	30131210
4,990	+0,004	6	75	12	36	39	35	4	30131212
5,000	H7	6	75	12	36	39	35	4	30131214
5,010	+0,004	6	75	12	36	39	35	4	30131216
5,020	+0,004	6	75	12	36	39	35	4	30131218
5,030	+0,004	6	75	12	36	39	35	4	30131220
5,500	H7	6	75	12	36	39	35	4	30131222
5,970	+0,004	6	75	12	36	39	35	4	30131224
5,980	+0,004	6	75	12	36	39	35	4	30131226
5,990	+0,004	6	75	12	36	39	35	4	30131228
6,000	H7	6	75	12	36	39	35	4	30131230
6,010	+0,004	6	75	12	36	39	35	4	30131232
6,020	+0,004	6	75	12	36	39	35	4	30131234
6,030	+0,004	6	75	12	36	39	35	4	30131236
6,500	H7	8	100	16	36	64	59	6	30131238
7,000	H7	8	100	16	36	64	59	6	30131240
7,500	H7	8	100	16	36	64	60	6	30131242
7,970	+0,004	8	100	16	36	64	60	6	30131244
7,980	+0,004	8	100	16	36	64	60	6	30131246
7,990	+0,004	8	100	16	36	64	60	6	30131248
8,000	H7	8	100	16	36	64	60	6	30131250
8,010	+0,004	8	100	16	36	64	60	6	30131252
8,020	+0,004	8	100	16	36	64	60	6	30131254

HNC I B040260, fixed design for through bore, internal coolant supply

Dimensions								z	Order no.
d ₁	Tolerance	d ₂ h6	l ₁	l ₂	l ₃	l ₄	l ₅		
8,030	+0,004	8	100	16	36	64	60	6	30131256
8,500	H7	10	100	20	40	60	55	6	30131258
9,000	H7	10	100	20	40	60	55	6	30131260
9,500	H7	10	120	20	40	80	76	6	30131262
9,970	+0,004	10	120	20	40	80	76	6	30131264
9,980	+0,004	10	120	20	40	80	76	6	30131266
9,990	+0,004	10	120	20	40	80	76	6	30131268
10,000	H7	10	120	20	40	80	76	6	30131270
10,010	+0,004	10	120	20	40	80	76	6	30131272
10,020	+0,004	10	120	20	40	80	76	6	30131274
10,030	+0,004	10	120	20	40	80	76	6	30131276
10,500	H7	12	120	20	45	75	70	6	30131278
11,000	H7	12	120	20	45	75	70	6	30131280
11,500	H7	12	120	20	45	75	71	6	30131282
11,970	+0,004	12	120	20	45	75	71	6	30131284
11,980	+0,004	12	120	20	45	75	71	6	30131286
11,990	+0,004	12	120	20	45	75	71	6	30131288
12,000	H7	12	120	20	45	75	71	6	30131290
12,010	+0,004	12	120	20	45	75	71	6	30131292
12,020	+0,004	12	120	20	45	75	71	6	30131294
12,030	+0,004	12	120	20	45	75	71	6	30131296
13,000	H7	14	130	22	45	85	80	6	30131298
14,000	H7	14	130	22	45	85	80	6	30131300
15,000	H7	16	130	22	48	82	77	6	30131302
16,000	H7	16	150	25	48	102	97	6	30131304
17,000	H7	18	150	25	48	102	97	8	30131306
18,000	H7	18	150	25	48	102	97	8	30131308
19,000	H7	20	150	25	50	100	95	8	30131310
20,000	H7	20	150	25	50	100	95	8	30131312

Configurable features

Bore diameter tolerance ≥ IT6:
 - Diameter in increments of 0.001 mm freely selectable
 - Can be ordered in tolerance ≥ IT6



Specification:
 B040260[Diameter][Tolerance]

G variant (see page 303):
 - Diameter in increments of 0.001 mm freely selectable
 - Can be ordered from tolerances ≥ 3 μm

G variant specification:
 B040260[Diameter][Tolerance]

IT6 tolerance example:
 B040260-Ø16.350H6

Bore diameter d₁ = 16.350 H6

G variant example:
 B040260-Ø16.350-3

Special tool diameter d₁ = 16.350 -3 μm

Dimensions of configurable series IT6

d ₁	d ₂	l ₁	l ₂	l ₃	l ₄	l ₅	z
2,800-3,700*	4	65	12	28	37	34	4
3,701-6,200	6	75	12	36	39	34	4
6,201-7,200	8	100	16	36	64	59	6
7,201-8,200	8	100	16	36	64	60	6
8,201-9,200	10	100	20	40	60	55	6
9,201-10,200	10	120	20	40	80	76	6
10,201-11,200	12	120	20	45	75	70	6
11,201-12,200	12	120	20	45	75	71	6
12,201-14,200	14	130	22	45	85	80	6
14,201-15,200	16	130	22	48	82	77	6
15,201-16,200	16	150	25	48	102	97	6
16,201-18,200	18	150	25	48	102	97	8/6
18,201-20,200	20	150	25	50	100	95	8/6

* ≤ d₁ 3.000 mm only IT7 possible.

Dimensions in mm.

For cutting data recommendations, see end of chapter.

HNC-Speed I B043260

Fixed design for through bore, internal coolant supply

Design:

Diameter: 2.800 - 20.200 mm
 Cutting direction: Right-hand cutting
 Cutting material: Solid carbide, BSP-coated (HP145)
 Groove direction: Spiral fluted
 Geometry: HPC, EU spacing

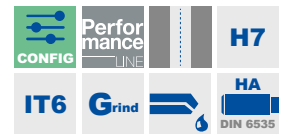
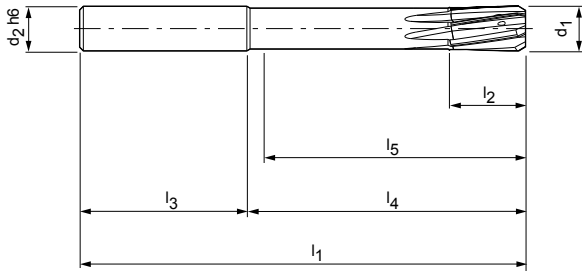

Preferred series available from stock in H7 | +0.004

Dimensions								z	Order no.
d ₁	Tolerance	d ₂ h6	l ₁	l ₂	l ₃	l ₄	l ₅		
3,000	H7	4	65	12	28	37	34	4	30402444
3,200	H7	4	65	12	28	37	34	4	30402446
3,500	H7	4	65	12	28	37	34	4	30402448
3,970	+0,004	6	75	12	36	39	34	4	30131436
3,980	+0,004	6	75	12	36	39	34	4	30131438
3,990	+0,004	6	75	12	36	39	34	4	30131440
4,000	H7	6	75	12	36	39	34	4	30131442
4,010	+0,004	6	75	12	36	39	34	4	30131444
4,020	+0,004	6	75	12	36	39	34	4	30131446
4,030	+0,004	6	75	12	36	39	34	4	30131448
4,500	H7	6	75	12	36	39	34	4	30131450
4,970	+0,004	6	75	12	36	39	35	4	30131452
4,980	+0,004	6	75	12	36	39	35	4	30131454
4,990	+0,004	6	75	12	36	39	35	4	30131456
5,000	H7	6	75	12	36	39	35	4	30131458
5,010	+0,004	6	75	12	36	39	35	4	30131460
5,020	+0,004	6	75	12	36	39	35	4	30131462
5,030	+0,004	6	75	12	36	39	35	4	30131464
5,500	H7	6	75	12	36	39	35	4	30131466
5,970	+0,004	6	75	12	36	39	35	4	30131468
5,980	+0,004	6	75	12	36	39	35	4	30131470
5,990	+0,004	6	75	12	36	39	35	4	30131472
6,000	H7	6	75	12	36	39	35	4	30131474
6,010	+0,004	6	75	12	36	39	35	4	30131476
6,020	+0,004	6	75	12	36	39	35	4	30131478
6,030	+0,004	6	75	12	36	39	35	4	30131480
6,500	H7	8	100	16	36	64	59	6	30131482
7,000	H7	8	100	16	36	64	59	6	30131484
7,500	H7	8	100	16	36	64	60	6	30131486
7,970	+0,004	8	100	16	36	64	60	6	30131488
7,980	+0,004	8	100	16	36	64	60	6	30131490
7,990	+0,004	8	100	16	36	64	60	6	30131492
8,000	H7	8	100	16	36	64	60	6	30131494
8,010	+0,004	8	100	16	36	64	60	6	30131496
8,020	+0,004	8	100	16	36	64	60	6	30131498

HNC-Speed I B043260, fixed design for through bore, internal coolant supply

Dimensions								z	Order no.
d ₁	Tolerance	d ₂ h6	l ₁	l ₂	l ₃	l ₄	l ₅		
8,030	+0,004	8	100	16	36	64	60	6	30131500
8,500	H7	10	100	20	40	60	55	6	30131502
9,000	H7	10	100	20	40	60	55	6	30131504
9,500	H7	10	120	20	40	80	76	6	30131506
9,970	+0,004	10	120	20	40	80	76	6	30131508
9,980	+0,004	10	120	20	40	80	76	6	30131510
9,990	+0,004	10	120	20	40	80	76	6	30131512
10,000	H7	10	120	20	40	80	76	6	30131514
10,010	+0,004	10	120	20	40	80	76	6	30131516
10,020	+0,004	10	120	20	40	80	76	6	30131518
10,030	+0,004	10	120	20	40	80	76	6	30131520
10,500	H7	12	120	20	45	75	70	6	30131522
11,000	H7	12	120	20	45	75	70	6	30131524
11,500	H7	12	120	20	45	75	71	6	30131526
11,970	+0,004	12	120	20	45	75	71	6	30131528
11,980	+0,004	12	120	20	45	75	71	6	30131530
11,990	+0,004	12	120	20	45	75	71	6	30131532
12,000	H7	12	120	20	45	75	71	6	30131534
12,010	+0,004	12	120	20	45	75	71	6	30131536
12,020	+0,004	12	120	20	45	75	71	6	30131538
12,030	+0,004	12	120	20	45	75	71	6	30131540
13,000	H7	14	130	22	45	85	80	6	30131542
14,000	H7	14	130	22	45	85	80	6	30131544
15,000	H7	16	130	22	48	82	77	6	30131546
16,000	H7	16	150	25	48	102	97	6	30131548
17,000	H7	18	150	25	48	102	97	8	30131550
18,000	H7	18	150	25	48	102	97	8	30131552
19,000	H7	20	150	25	50	100	95	8	30131554
20,000	H7	20	150	25	50	100	95	8	30131556

Configurable features



Bore diameter tolerance ≥ IT6:
 - Diameter in increments of 0.001 mm freely selectable
 - Can be ordered in tolerance ≥ IT6



Specification:
 B043260[**Diameter**][**Tolerance**]

G variant (see page 303):
 - Diameter in increments of 0.001 mm freely selectable
 - Can be ordered from tolerances ≥ 4 μm

G variant specification:
 B043260[**Diameter**][**Tolerance**]

IT6 tolerance example:
 B043260-Ø16.350H6

Bore diameter d₁ = 16.350 H6

G variant example:
 B043260-Ø16.350-4

Special tool diameter d₁ = 16.350 -4 μm

Dimensions of configurable series IT6

d ₁	d ₂	l ₁	l ₂	l ₃	l ₄	l ₅	z
2,800-3,700*	4	65	12	28	37	34	4
3,701-6,200	6	75	12	36	39	34	4
6,201-7,200	8	100	16	36	64	59	6
7,201-8,200	8	100	16	36	64	60	6
8,201-9,200	10	100	20	40	60	55	6
9,201-10,200	10	120	20	40	80	76	6
10,201-11,200	12	120	20	45	75	70	6
11,201-12,200	12	120	20	45	75	71	6
12,201-14,200	14	130	22	45	85	80	6
14,201-15,200	16	130	22	48	82	77	6
15,201-16,200	16	150	25	48	102	97	6
16,201-18,200	18	150	25	48	102	97	8/6
18,201-20,200	20	150	25	50	100	95	8/6

* ≤ d₁ 3.000 mm only IT7 possible.

Dimensions in mm.

For cutting data recommendations, see end of chapter.

HNC-VA | B043270

Fixed design for through bore, internal coolant supply

Design:

Diameter: 2.800 - 20.200 mm
 Cutting direction: Right-hand cutting
 Cutting material: Solid carbide, BVA-coated (HP145)
 Groove direction: Spiral fluted
 Geometry: HPC, EU spacing

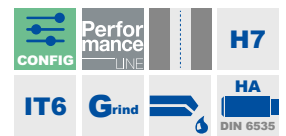
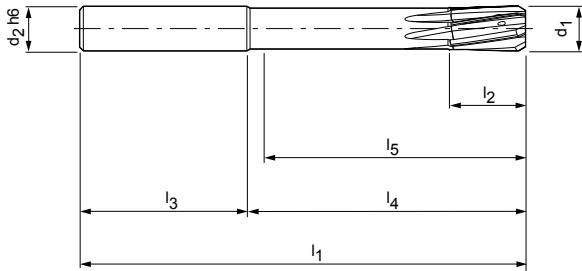

Preferred series available from stock in H7 | +0.004

Dimensions								z	Order no.
d ₁	Tolerance	d ₂ h6	l ₁	l ₂	l ₃	l ₄	l ₅		
3,970	+0,004	6	75	12	36	39	34	4	30195076
3,980	+0,004	6	75	12	36	39	34	4	30195079
3,990	+0,004	6	75	12	36	39	34	4	30195080
4,000	H7	6	75	12	36	39	34	4	30195082
4,010	+0,004	6	75	12	36	39	34	4	30195083
4,020	+0,004	6	75	12	36	39	34	4	30195085
4,030	+0,004	6	75	12	36	39	34	4	30195086
4,500	H7	6	75	12	36	39	34	4	30195087
4,970	+0,004	6	75	12	36	39	35	4	30195089
4,980	+0,004	6	75	12	36	39	35	4	30195090
4,990	+0,004	6	75	12	36	39	35	4	30195092
5,000	H7	6	75	12	36	39	35	4	30195094
5,010	+0,004	6	75	12	36	39	35	4	30195095
5,020	+0,004	6	75	12	36	39	35	4	30195097
5,030	+0,004	6	75	12	36	39	35	4	30195098
5,500	H7	6	75	12	36	39	35	4	30195101
5,970	+0,004	6	75	12	36	39	35	4	30195102
5,980	+0,004	6	75	12	36	39	35	4	30195104
5,990	+0,004	6	75	12	36	39	35	4	30195106
6,000	H7	6	75	12	36	39	35	4	30195108
6,010	+0,004	6	75	12	36	39	35	4	30195109
6,020	+0,004	6	75	12	36	39	35	4	30195111
6,030	+0,004	6	75	12	36	39	35	4	30195112
6,500	H7	8	100	16	36	64	59	6	30195113
7,000	H7	8	100	16	36	64	59	6	30195115
7,500	H7	8	100	16	36	64	60	6	30195116
7,970	+0,004	8	100	16	36	64	60	6	30195117
7,980	+0,004	8	100	16	36	64	60	6	30195119
7,990	+0,004	8	100	16	36	64	60	6	30195121
8,000	H7	8	100	16	36	64	60	6	30195122
8,010	+0,004	8	100	16	36	64	60	6	30195123
8,020	+0,004	8	100	16	36	64	60	6	30195124
8,030	+0,004	8	100	16	36	64	60	6	30195125
8,500	H7	10	100	20	40	60	55	6	30195127
9,000	H7	10	100	20	40	60	55	6	30195132

HNC-VA | B043270, fixed design for through bore, internal coolant supply

Dimensions								z	Order no.
d ₁	Tolerance	d ₂ h6	l ₁	l ₂	l ₃	l ₄	l ₅		
9,500	H7	10	120	20	40	80	76	6	30195133
9,970	+0,004	10	120	20	40	80	76	6	30195134
9,980	+0,004	10	120	20	40	80	76	6	30195135
9,990	+0,004	10	120	20	40	80	76	6	30195136
10,000	H7	10	120	20	40	80	76	6	30195138
10,010	+0,004	10	120	20	40	80	76	6	30195140
10,020	+0,004	10	120	20	40	80	76	6	30195142
10,030	+0,004	10	120	20	40	80	76	6	30195143
10,500	H7	12	120	20	45	75	70	6	30195144
11,000	H7	12	120	20	45	75	70	6	30195146
11,500	H7	12	120	20	45	75	71	6	30195147
11,970	+0,004	12	120	20	45	75	71	6	30195148
11,980	+0,004	12	120	20	45	75	71	6	30195150
11,990	+0,004	12	120	20	45	75	71	6	30195153
12,000	H7	12	120	20	45	75	71	6	30195155
12,010	+0,004	12	120	20	45	75	71	6	30195159
12,020	+0,004	12	120	20	45	75	71	6	30195165
12,030	+0,004	12	120	20	45	75	71	6	30195168
13,000	H7	14	130	22	45	85	80	6	30195169
14,000	H7	14	130	22	45	85	80	6	30195170
15,000	H7	16	130	22	48	82	77	6	30195172
16,000	H7	16	150	25	48	102	97	6	30195175
17,000	H7	18	150	25	48	102	97	8	30195178
18,000	H7	18	150	25	48	102	97	8	30195182
19,000	H7	20	150	25	50	100	95	8	30195185
20,000	H7	20	150	25	50	100	95	8	30195188

Configurable features



Bore diameter tolerance ≥ IT6:
 - Diameter in increments of 0.001 mm freely selectable
 - Can be ordered in tolerance ≥ IT6



Specification:
 B043270[**Diameter**][**Tolerance**]

G variant (see page 303):
 - Diameter in increments of 0.001 mm freely selectable
 - Can be ordered from tolerances ≥ 4 μm

G variant specification:
 B043270[**Diameter**][**Tolerance**]

IT6 tolerance example:
 B043270-**Ø16.350H6**

Bore diameter d₁ = 16.350 H6

G variant example:
 B043270-**Ø16.350-4**

Special tool diameter d₁ = 16.350 -4 μm

Dimensions of configurable series IT6

d ₁	d ₂	l ₁	l ₂	l ₃	l ₄	l ₅	z
2,800-3,700*	4	65	12	28	37	34	4
3,701-6,200	6	75	12	36	39	34	4
6,201-7,200	8	100	16	36	64	59	6
7,201-8,200	8	100	16	36	64	60	6
8,201-9,200	10	100	20	40	60	55	6
9,201-10,200	10	120	20	40	80	76	6
10,201-11,200	12	120	20	45	75	70	6
11,201-12,200	12	120	20	45	75	71	6
12,201-14,200	14	130	22	45	85	80	6
14,201-15,200	16	130	22	48	82	77	6
15,201-16,200	16	150	25	48	102	97	6
16,201-18,200	18	150	25	48	102	97	8/6
18,201-20,200	20	150	25	50	100	95	8/6

* ≤ d₁ 3.000 mm only IT7 possible.

HNC-TI | B043272

Fixed design for through bore, internal coolant supply

Design:

Diameter: 2.800 - 20.200 mm
 Cutting direction: Right-hand cutting
 Cutting material: Solid carbide, BTI-coated (HP625)
 Groove direction: Spiral fluted
 Geometry: HPC, EU spacing

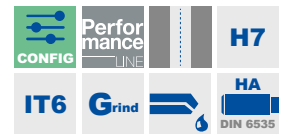
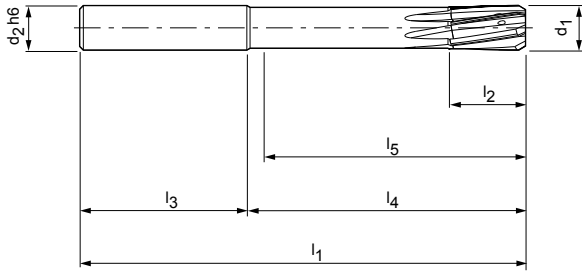

Preferred series available from stock in H7 | +0.004

Dimensions								z	Order no.
d ₁	Tolerance	d ₂ h6	l ₁	l ₂	l ₃	l ₄	l ₅		
3,970	+0,004	6	75	12	36	39	34	4	30585253
3,980	+0,004	6	75	12	36	39	34	4	30585254
3,990	+0,004	6	75	12	36	39	34	4	30585255
4,000	H7	6	75	12	36	39	34	4	30585228
4,010	+0,004	6	75	12	36	39	34	4	30585256
4,020	+0,004	6	75	12	36	39	34	4	30585257
4,030	+0,004	6	75	12	36	39	34	4	30585258
4,500	H7	6	75	12	36	39	34	4	30585229
4,970	+0,004	6	75	12	36	39	35	4	30585259
4,980	+0,004	6	75	12	36	39	35	4	30585260
4,990	+0,004	6	75	12	36	39	35	4	30585261
5,000	H7	6	75	12	36	39	35	4	30585230
5,010	+0,004	6	75	12	36	39	35	4	30585262
5,020	+0,004	6	75	12	36	39	35	4	30585263
5,030	+0,004	6	75	12	36	39	35	4	30585264
5,500	H7	6	75	12	36	39	35	4	30585231
5,970	+0,004	6	75	12	36	39	35	4	30585265
5,980	+0,004	6	75	12	36	39	35	4	30585266
5,990	+0,004	6	75	12	36	39	35	4	30585267
6,000	H7	6	75	12	36	39	35	4	30585232
6,010	+0,004	6	75	12	36	39	35	4	30585268
6,020	+0,004	6	75	12	36	39	35	4	30585269
6,030	+0,004	6	75	12	36	39	35	4	30585270
6,500	H7	8	100	16	36	64	59	6	30585233
7,000	H7	8	100	16	36	64	59	6	30585234
7,500	H7	8	100	16	36	64	60	6	30585235
7,970	+0,004	8	100	16	36	64	60	6	30585271
7,980	+0,004	8	100	16	36	64	60	6	30585272
7,990	+0,004	8	100	16	36	64	60	6	30585273
8,000	H7	8	100	16	36	64	60	6	30585236
8,010	+0,004	8	100	16	36	64	60	6	30585274
8,020	+0,004	8	100	16	36	64	60	6	30585275
8,030	+0,004	8	100	16	36	64	60	6	30585276
8,500	H7	10	100	20	40	60	55	6	30585237
9,000	H7	10	100	20	40	60	55	6	30585238

HNC-TI | B043272, fixed design for through bore, internal coolant supply

Dimensions								z	Order no.
d ₁	Tolerance	d ₂ h6	l ₁	l ₂	l ₃	l ₄	l ₅		
9,500	H7	10	120	20	40	80	76	6	30585239
9,970	+0,004	10	120	20	40	80	76	6	30585277
9,980	+0,004	10	120	20	40	80	76	6	30585278
9,990	+0,004	10	120	20	40	80	76	6	30585279
10,000	H7	10	120	20	40	80	76	6	30585240
10,010	+0,004	10	120	20	40	80	76	6	30585280
10,020	+0,004	10	120	20	40	80	76	6	30585281
10,030	+0,004	10	120	20	40	80	76	6	30585282
10,500	H7	12	120	20	45	75	70	6	30585241
11,000	H7	12	120	20	45	75	70	6	30585242
11,500	H7	12	120	20	45	75	71	6	30585243
11,970	+0,004	12	120	20	45	75	71	6	30585283
11,980	+0,004	12	120	20	45	75	71	6	30585284
11,990	+0,004	12	120	20	45	75	71	6	30585285
12,000	H7	12	120	20	45	75	71	6	30585244
12,010	+0,004	12	120	20	45	75	71	6	30585286
12,020	+0,004	12	120	20	45	75	71	6	30585287
12,030	+0,004	12	120	20	45	75	71	6	30585288
13,000	H7	14	130	22	45	85	80	6	30585245
14,000	H7	14	130	22	45	85	80	6	30585246
15,000	H7	16	130	22	48	82	77	6	30585247
16,000	H7	16	150	25	48	102	97	6	30585248
17,000	H7	18	150	25	48	102	97	8	30585249
18,000	H7	18	150	25	48	102	97	8	30585250
19,000	H7	20	150	25	50	100	95	8	30585251
20,000	H7	20	150	25	50	100	95	8	30585252

Configurable features



Bore diameter tolerance \geq IT6:
 - Diameter in increments of 0.001 mm freely selectable
 - Can be ordered in tolerance \geq IT6



Specification:
 B043272[Diameter][Tolerance]

G variant (see page 303):
 - Diameter in increments of 0.001 mm freely selectable
 - Can be ordered from tolerances \geq 4 μ m

G variant specification:
 B043272[Diameter][Tolerance]

IT6 tolerance example:
 B043272-**Ø16.350H6**

Bore diameter d₁ = 16.350 H6

G variant example:
 B043272-**Ø16.350-4**

Special tool diameter d₁ = 16.350 -4 μ m

Dimensions of configurable series IT6

d ₁	d ₂	l ₁	l ₂	l ₃	l ₄	l ₅	z
2,800-3,700*	4	65	12	28	37	34	4
3,701-6,200	6	75	12	36	39	34	4
6,201-7,200	8	100	16	36	64	59	6
7,201-8,200	8	100	16	36	64	60	6
8,201-9,200	10	100	20	40	60	55	6
9,201-10,200	10	120	20	40	80	76	6
10,201-11,200	12	120	20	45	75	70	6
11,201-12,200	12	120	20	45	75	71	6
12,201-14,200	14	130	22	45	85	80	6
14,201-15,200	16	130	22	48	82	77	6
15,201-16,200	16	150	25	48	102	97	6
16,201-18,200	18	150	25	48	102	97	8/6
18,201-20,200	20	150	25	50	100	95	8/6

* \leq d₁ 3.000 mm only IT7 possible.

Dimensions in mm.

For cutting data recommendations, see end of chapter.

HNC-Diamond I B043290

Fixed design for through bore, internal coolant supply

Design:

Diameter: 2.800 - 20.200 mm
 Cutting direction: Right-hand cutting
 Cutting material: Solid carbide, diamond-coated (HC614)
 Groove direction: Spiral fluted
 Geometry: HPC, EU spacing

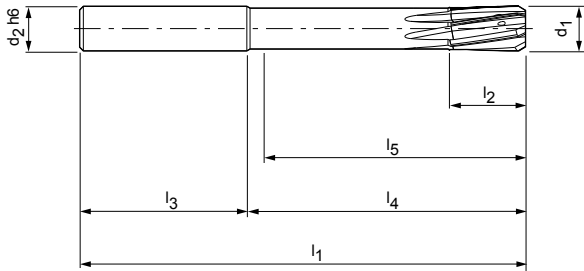

N	1.1	1.2	1.3	1.4	2.1	2.2	2.3	3.1	4.1	4.2	4.3	C	1.1	1.2	1.3	2.1	3.1	4.1	4.2	4.3	4.4	5.1	5.2
---	-----	-----	-----	-----	-----	-----	-----	-----	-----	-----	-----	---	-----	-----	-----	-----	-----	-----	-----	-----	-----	-----	-----

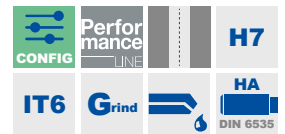

Preferred series in H7

Dimensions							z	Order no.
d ₁ H7	d ₂ h6	l ₁	l ₂	l ₃	l ₄	l ₅		
4,000	6	75	12	36	39	34	4	30476709
4,500	6	75	12	36	39	34	4	30476711
5,000	6	75	12	36	39	35	4	30476714
5,500	6	75	12	36	39	35	4	30476718
6,000	6	75	12	36	39	35	4	30476719
6,500	8	100	16	36	64	59	6	30412526
7,000	8	100	16	36	64	59	6	30476727
7,500	8	100	16	36	64	60	6	30476728
8,000	8	100	16	36	64	60	6	30476729
8,500	10	100	20	40	60	55	6	30476730
9,000	10	100	20	40	60	55	6	30412525
9,500	10	120	20	40	80	76	6	30476732
10,000	10	120	20	40	80	76	6	30412529
10,500	12	120	20	45	75	70	6	30476693
11,000	12	120	20	45	75	70	6	30476694
11,500	12	120	20	45	75	71	6	30476695
12,000	12	120	20	45	75	71	6	30412530
13,000	14	130	22	45	85	80	6	30476696
14,000	14	130	22	45	85	80	6	30466585
15,000	16	130	22	48	82	77	6	30476699
16,000	16	150	25	48	102	97	6	30476702
17,000	18	150	25	48	102	97	8	30476704
18,000	18	150	25	48	102	97	8	30476706
19,000	20	150	25	50	100	95	8	30476707
20,000	20	150	25	50	100	95	8	30412531

Configurable features



Bore diameter tolerance \geq IT6:
 - Diameter in increments of 0.001 mm freely selectable
 - Can be ordered in tolerance \geq IT6



Specification:
 B043290[Diameter][Tolerance]

G variant (see page 303):
 - Diameter in increments of 0.001 mm freely selectable
 - Can be ordered from tolerances $\geq 4 \mu\text{m}$

G variant specification:
 B043290[Diameter][Tolerance]

IT6 tolerance example:
 B043290-Ø16.350H6

Bore diameter $d_1 = 16.350 \text{ H6}$

G variant example:
 B043290-Ø16.350-4

Special tool diameter $d_1 = 16.350 -4 \mu\text{m}$

Dimensions of configurable series IT6

d_1	d_2	l_1	l_2	l_3	l_4	l_5	z
2,800-3,700*	4	65	12	28	37	34	4
3,701-6,200	6	75	12	36	39	34	4
6,201-7,200	8	100	16	36	64	59	6
7,201-8,200	8	100	16	36	64	60	6
8,201-9,200	10	100	20	40	60	55	6
9,201-10,200	10	120	20	40	80	76	6
10,201-11,200	12	120	20	45	75	70	6
11,201-12,200	12	120	20	45	75	71	6
12,201-14,200	14	130	22	45	85	80	6
14,201-15,200	16	130	22	48	82	77	6
15,201-16,200	16	150	25	48	102	97	6
16,201-18,200	18	150	25	48	102	97	8/6
18,201-20,200	20	150	25	50	100	95	8/6

* $\leq d_1$ 3,000 mm only IT7 possible.

HNC-AL | B043250

Fixed design for through bore, internal coolant supply

Design:

Diameter: 2.800 - 20.200 mm
 Cutting direction: Right-hand cutting
 Cutting material: Solid carbide, BAL-coated (HP622)
 Groove direction: Straight fluted
 Geometry: HPC, EU spacing

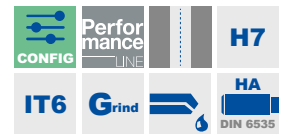
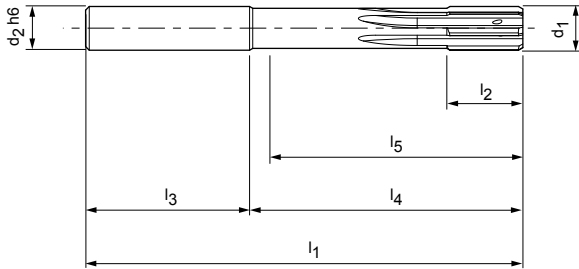

Preferred series in H7

Dimensions							z	Order no.
d ₁ H7	d ₂ h6	l ₁	l ₂	l ₃	l ₄	l ₅		
4,000	6	75	12	36	39	34	4	30384144
4,500	6	75	12	36	39	34	4	30384145
5,000	6	75	12	36	39	35	4	30385390
5,500	6	75	12	36	39	35	4	30385391
6,000	6	75	12	36	39	35	4	30385392
6,500	8	100	16	36	64	59	6	30385393
7,000	8	100	16	36	64	59	6	30385394
7,500	8	100	16	36	64	60	6	30385396
8,000	8	100	16	36	64	60	6	30385397
8,500	10	100	20	40	60	55	6	30385398
9,000	10	100	20	40	60	55	6	30385401
9,500	10	120	20	40	80	76	6	30385403
10,000	10	120	20	40	80	76	6	30385405
10,500	12	120	20	45	75	70	6	30385407
11,000	12	120	20	45	75	70	6	30385408
11,500	12	120	20	45	75	71	6	30385409
12,000	12	120	20	45	75	71	6	30385410
13,000	14	130	22	45	85	80	6	30385411
14,000	14	130	22	45	85	80	6	30385413
15,000	16	130	22	48	82	77	6	30385415
16,000	16	150	25	48	102	97	6	30385416
17,000	18	150	25	48	102	97	6	30385418
18,000	18	150	25	48	102	97	6	30385421
19,000	20	150	25	50	100	95	6	30385423
20,000	20	150	25	50	100	95	6	30385425

Configurable features

**Bore diameter tolerance \geq IT6:**

- Diameter in increments of 0.001 mm freely selectable
- Can be ordered in tolerance \geq IT6

**Specification:**

B043250[Diameter][Tolerance]

G variant (see page 303):

- Diameter in increments of 0.001 mm freely selectable
- Can be ordered from tolerances $\geq 4 \mu\text{m}$

G variant specification:

B043250[Diameter][Tolerance]

IT6 tolerance example:

B043250-Ø16.350H6

Bore diameter $d_1 = 16.350 \text{ H6}$ **G variant example:**

B043250-Ø16.350-4

Special tool diameter $d_1 = 16.350 -4 \mu\text{m}$

Dimensions of configurable series IT6

d_1	d_2	l_1	l_2	l_3	l_4	l_5	z
2,800-3,700*	4	65	12	28	37	34	4
3,701-6,200	6	75	12	36	39	34	4
6,201-7,200	8	100	16	36	64	59	6
7,201-8,200	8	100	16	36	64	60	6
8,201-9,200	10	100	20	40	60	55	6
9,201-10,200	10	120	20	40	80	76	6
10,201-11,200	12	120	20	45	75	70	6
11,201-12,200	12	120	20	45	75	71	6
12,201-14,200	14	130	22	45	85	80	6
14,201-15,200	16	130	22	48	82	77	6
15,201-16,200	16	150	25	48	102	97	6
16,201-18,200	18	150	25	48	102	97	8/6
18,201-20,200	20	150	25	50	100	95	8/6

* $\leq d_1$ 3.000 mm only IT7 possible.

HNC-HT | B043280

Fixed design for through bore, internal coolant supply

Design:

Diameter: 2.800 - 20.200 mm
 Cutting direction: Right-hand cutting
 Cutting material: Solid carbide, BHV-coated (HP141)
 Groove direction: Straight fluted
 Geometry: HPC, EU spacing
 Hardness level: Up to 60 HRC

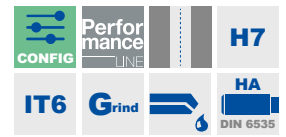
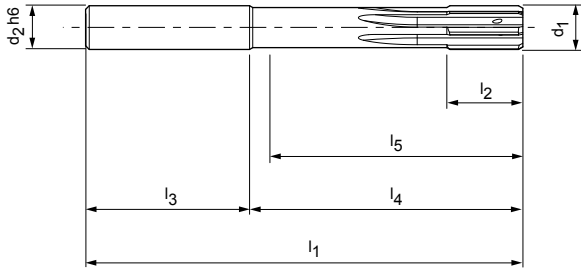

Preferred series available from stock in H7 | +0.004

Dimensions								z	Order no.
d ₁	Tolerance	d ₂ h6	l ₁	l ₂	l ₃	l ₄	l ₅		
3,970	+0,004	6	75	12	36	39	34	4	30300822
3,980	+0,004	6	75	12	36	39	34	4	30300837
3,990	+0,004	6	75	12	36	39	34	4	30300838
4,000	H7	6	75	12	36	39	34	4	30300839
4,010	+0,004	6	75	12	36	39	34	4	30300844
4,020	+0,004	6	75	12	36	39	34	4	30300853
4,030	+0,004	6	75	12	36	39	34	4	30300861
4,500	H7	6	75	12	36	39	34	4	30300865
4,970	+0,004	6	75	12	36	39	35	4	30300866
4,980	+0,004	6	75	12	36	39	35	4	30300867
4,990	+0,004	6	75	12	36	39	35	4	30300868
5,000	H7	6	75	12	36	39	35	4	30300869
5,010	+0,004	6	75	12	36	39	35	4	30300871
5,020	+0,004	6	75	12	36	39	35	4	30300873
5,030	+0,004	6	75	12	36	39	35	4	30300875
5,500	H7	6	75	12	36	39	35	4	30300876
5,970	+0,004	6	75	12	36	39	35	4	30300877
5,980	+0,004	6	75	12	36	39	35	4	30300878
5,990	+0,004	6	75	12	36	39	35	4	30300879
6,000	H7	6	75	12	36	39	35	4	30300882
6,010	+0,004	6	75	12	36	39	35	4	30300884
6,020	+0,004	6	75	12	36	39	35	4	30300885
6,030	+0,004	6	75	12	36	39	35	4	30300911
6,500	H7	8	100	16	36	64	59	6	30300912
7,000	H7	8	100	16	36	64	59	6	30300913
7,500	H7	8	100	16	36	64	60	6	30300914
7,970	+0,004	8	100	16	36	64	60	6	30300955
7,980	+0,004	8	100	16	36	64	60	6	30300957
7,990	+0,004	8	100	16	36	64	60	6	30300959
8,000	H7	8	100	16	36	64	60	6	30228276
8,010	+0,004	8	100	16	36	64	60	6	30300960
8,020	+0,004	8	100	16	36	64	60	6	30300961
8,030	+0,004	8	100	16	36	64	60	6	30300962
8,500	H7	10	100	20	40	60	55	6	30300963
9,000	H7	10	100	20	40	60	55	6	30300964

HNC-HT I B043280, fixed design for through bore, internal coolant supply

Dimensions								z	Order no.
d ₁	Tolerance	d ₂ h6	l ₁	l ₂	l ₃	l ₄	l ₅		
9,500	H7	10	120	20	40	80	76	6	30300965
9,970	+0,004	10	120	20	40	80	76	6	30300966
9,980	+0,004	10	120	20	40	80	76	6	30300967
9,990	+0,004	10	120	20	40	80	76	6	30300968
10,000	H7	10	120	20	40	80	76	6	30300972
10,010	+0,004	10	120	20	40	80	76	6	30300974
10,020	+0,004	10	120	20	40	80	76	6	30300976
10,030	+0,004	10	120	20	40	80	76	6	30300977
10,500	H7	12	120	20	45	75	70	6	30300979
11,000	H7	12	120	20	45	75	70	6	30300980
11,500	H7	12	120	20	45	75	71	6	30300982
11,970	+0,004	12	120	20	45	75	71	6	30300983
11,980	+0,004	12	120	20	45	75	71	6	30300985
11,990	+0,004	12	120	20	45	75	71	6	30300986
12,000	H7	12	120	20	45	75	71	6	30228277
12,010	+0,004	12	120	20	45	75	71	6	30300994
12,020	+0,004	12	120	20	45	75	71	6	30300995
12,030	+0,004	12	120	20	45	75	71	6	30300996
13,000	H7	14	130	22	45	85	80	6	30300998
14,000	H7	14	130	22	45	85	80	6	30300999
15,000	H7	16	130	22	48	82	77	6	30301001
16,000	H7	16	150	25	48	102	97	6	30228279
17,000	H7	18	150	25	48	102	97	6	30301002
18,000	H7	18	150	25	48	102	97	6	30301003
19,000	H7	20	150	25	50	100	95	6	30301004
20,000	H7	20	150	25	50	100	95	6	30301005

Configurable features



Bore diameter tolerance ≥ IT6:
 - Diameter in increments of 0.001 mm freely selectable
 - Can be ordered in tolerance ≥ IT6



Specification:
 B043280[Diameter][Tolerance]

G variant (see page 303):
 - Diameter in increments of 0.001 mm freely selectable
 - Can be ordered from tolerances ≥ 4 μm

G variant specification:
 B043280[Diameter][Tolerance]

IT6 tolerance example:
 B043280-Ø16.350H6

Bore diameter d₁ = 16.350 H6

G variant example:
 B043280-Ø16.350-4

Special tool diameter d₁ = 16.350 -4 μm

Dimensions of configurable series IT6

d ₁	d ₂	l ₁	l ₂	l ₃	l ₄	l ₅	z
2,800-3,700*	4	65	12	28	37	34	4
3,701-6,200	6	75	12	36	39	34	4
6,201-7,200	8	100	16	36	64	59	6
7,201-8,200	8	100	16	36	64	60	6
8,201-9,200	10	100	20	40	60	55	6
9,201-10,200	10	120	20	40	80	76	6
10,201-11,200	12	120	20	45	75	70	6
11,201-12,200	12	120	20	45	75	71	6
12,201-14,200	14	130	22	45	85	80	6
14,201-15,200	16	130	22	48	82	77	6
15,201-16,200	16	150	25	48	102	97	6
16,201-18,200	18	150	25	48	102	97	8/6
18,201-20,200	20	150	25	50	100	95	8/6

* ≤ d₁ 3.000 mm only IT7 possible.

Dimensions in mm.

For cutting data recommendations, see end of chapter.

PcBN reamer | B040356

Fixed design for through bore, internal coolant supply

Design:

Diameter:

Cutting direction:

Cutting material:

Groove direction:

Geometry:

Hardness level:

3.000 - 10.200 mm

Right-hand cutting

PcBN head

Straight fluted

HPC, EU spacing

Up to 68 HRC

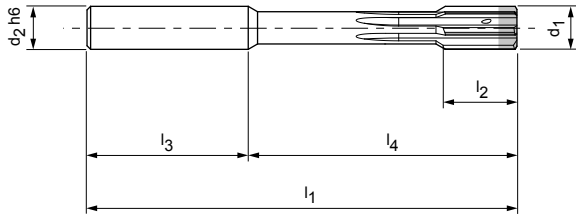

Preferred series in H7

Dimensions						z	Order no.
d ₁ H7	d ₂ h6	l ₁	l ₂	l ₃	l ₄		
3,000	4	65	12	28	37	6	30601315
3,500	4	65	12	28	37	6	30601316
4,000	6	75	12	36	39	6	30556056
4,500	6	75	12	36	39	6	30601317
5,000	6	75	12	36	39	6	30601318
5,500	6	75	12	36	39	6	30601319
6,000	6	75	12	36	39	8	30591461
6,500	8	100	16	36	64	8	30601320
7,000	8	100	16	36	64	8	30601321
7,500	8	100	16	36	64	8	30601322
8,000	8	100	16	36	64	10	30589906
8,500	10	100	16	40	60	10	30601323
9,000	10	100	16	40	60	10	30601324
9,500	10	120	20	40	80	10	30601325
10,000	10	120	20	40	80	10	30601327

Configurable features

**Bore diameter tolerance \geq IT6:**

- Diameter in increments of 0.001 mm freely selectable
- Can be ordered in tolerance \geq IT6

**Specification:**

B040356[Diameter][Tolerance]

G variant (see page 303):

- Diameter in increments of 0.001 mm freely selectable
- Can be ordered from tolerances $\geq 3 \mu\text{m}$

G variant specification:

B040356[Diameter][Tolerance]

Dimensions of configurable series IT6

d_1	d_2 h6	l_1	l_2	l_3	l_4	z
3,001-3,710	4	65	12	28	37	6
3,711-5,710	6	75	12	36	39	6
4,211-4,710	6	75	12	36	39	6
4,711-5,210	6	75	12	36	39	6
5,711-6,210	6	75	12	36	39	8
6,211-6,710	8	100	16	36	64	8
6,711-7,210	8	100	16	36	64	8
7,711-8,210	8	100	16	36	64	10
8,211-9,210	10	100	16	40	60	10
9,211-10,200	10	120	20	40	80	10

IT6 tolerance example:B040356-~~008.350~~H6Bore diameter $d_1 = 8.350$ H6**G variant example:**B040356-~~008.350~~-3Special tool diameter $d_1 = 8.350 -3 \mu\text{m}$

HNC I B040261

Fixed design for blind bore, internal coolant supply

Design:

Diameter: 2.800 - 20.200 mm
 Cutting direction: Right-hand cutting
 Cutting material: Solid carbide, uncoated (HU612)
 Groove direction: Straight fluted
 Geometry: HPC, EU spacing

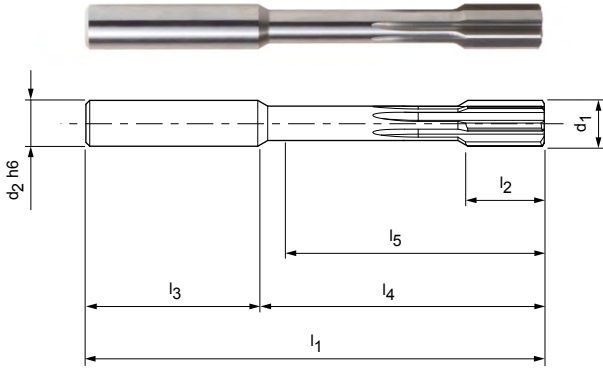

Preferred series available from stock in H7 | +0.004

Dimensions								z	Order no.
d_1	Tolerance	$d_2 \text{ h6}$	l_1	l_2	l_3	l_4	l_5		
3,000	H7	4	65	12	28	37	33	4	30402436
3,200	H7	4	65	12	28	37	33	4	30402437
3,500	H7	4	65	12	28	37	33	4	30402440
3,970	+0,004	6	75	12	36	39	34	4	30131314
3,980	+0,004	6	75	12	36	39	34	4	30131316
3,990	+0,004	6	75	12	36	39	34	4	30131318
4,000	H7	6	75	12	36	39	34	4	30131320
4,010	+0,004	6	75	12	36	39	34	4	30131322
4,020	+0,004	6	75	12	36	39	34	4	30131324
4,030	+0,004	6	75	12	36	39	34	4	30131326
4,500	H7	6	75	12	36	39	34	4	30131328
4,970	+0,004	6	75	12	36	39	34	4	30131330
4,980	+0,004	6	75	12	36	39	34	4	30131332
4,990	+0,004	6	75	12	36	39	34	4	30131334
5,000	H7	6	75	12	36	39	34	4	30131336
5,010	+0,004	6	75	12	36	39	34	4	30131338
5,020	+0,004	6	75	12	36	39	34	4	30131340
5,030	+0,004	6	75	12	36	39	34	4	30131342
5,500	H7	6	75	12	36	39	34	4	30131344
5,970	+0,004	6	75	12	36	39	34	4	30131346
5,980	+0,004	6	75	12	36	39	34	4	30131348
5,990	+0,004	6	75	12	36	39	34	4	30131350
6,000	H7	6	75	12	36	39	34	4	30131352
6,010	+0,004	6	75	12	36	39	34	4	30131354
6,020	+0,004	6	75	12	36	39	34	4	30131356
6,030	+0,004	6	75	12	36	39	34	4	30131358
6,500	H7	8	100	16	36	64	58	6	30131360
7,000	H7	8	100	16	36	64	58	6	30131362
7,500	H7	8	100	16	36	64	58	6	30131364
7,970	+0,004	8	100	16	36	64	58	6	30131366
7,980	+0,004	8	100	16	36	64	58	6	30131368
7,990	+0,004	8	100	16	36	64	58	6	30131370
8,000	H7	8	100	16	36	64	58	6	30131372
8,010	+0,004	8	100	16	36	64	58	6	30131374
8,020	+0,004	8	100	16	36	64	58	6	30131376

HNC I B040261, fixed design for blind bore, internal coolant supply

Dimensions								z	Order no.
d ₁	Tolerance	d ₂ h6	l ₁	l ₂	l ₃	l ₄	l ₅		
8,030	+0,004	8	100	16	36	64	58	6	30131378
8,500	H7	10	100	20	40	60	54	6	30131380
9,000	H7	10	100	20	40	60	54	6	30131382
9,500	H7	10	120	20	40	80	74	6	30131384
9,970	+0,004	10	120	20	40	80	74	6	30131386
9,980	+0,004	10	120	20	40	80	74	6	30131388
9,990	+0,004	10	120	20	40	80	74	6	30131390
10,000	H7	10	120	20	40	80	74	6	30131392
10,010	+0,004	10	120	20	40	80	74	6	30131394
10,020	+0,004	10	120	20	40	80	74	6	30131396
10,030	+0,004	10	120	20	40	80	74	6	30131398
10,500	H7	12	120	20	45	75	68	6	30131400
11,000	H7	12	120	20	45	75	68	6	30131402
11,500	H7	12	120	20	45	75	68	6	30131404
11,970	+0,004	12	120	20	45	75	68	6	30131406
11,980	+0,004	12	120	20	45	75	68	6	30131408
11,990	+0,004	12	120	20	45	75	68	6	30131410
12,000	H7	12	120	20	45	75	68	6	30131412
12,010	+0,004	12	120	20	45	75	68	6	30131414
12,020	+0,004	12	120	20	45	75	68	6	30131416
12,030	+0,004	12	120	20	45	75	68	6	30131418
13,000	H7	14	130	22	45	85	78	6	30131420
14,000	H7	14	130	22	45	85	78	6	30131422
15,000	H7	16	130	22	48	82	75	6	30131424
16,000	H7	16	150	25	48	102	95	6	30131426
17,000	H7	18	150	25	48	102	95	6	30131428
18,000	H7	18	150	25	48	102	95	6	30131430
19,000	H7	20	150	25	50	100	92	6	30131432
20,000	H7	20	150	25	50	100	92	6	30131434

Configurable features

Bore diameter tolerance \geq IT6:
 - Diameter in increments of 0.001 mm freely selectable
 - Can be ordered in tolerance \geq IT6



Specification:
 B040261[**Diameter**][**Tolerance**]

G variant (see page 303):
 - Diameter in increments of 0.001 mm freely selectable
 - Can be ordered from tolerances \geq 3 μ m

G variant specification:
 B040261[**Diameter**][**Tolerance**]

IT6 tolerance example:
 B040261-**Ø016.350H6**

Bore diameter d₁ = 16.350 H6

G variant example:
 B040261-**Ø016.350-3**

Special tool diameter d₁ = 16.350 -3 μ m

Dimensions of configurable series IT6

d ₁	d ₂	l ₁	l ₂	l ₃	l ₄	l ₅	z
2,800-3,700*	4	65	12	28	37	33	4
3,701-6,200	6	75	12	36	39	34	4
6,201-8,200	8	100	16	36	64	58	6
8,201-9,200	10	100	20	40	60	54	6
9,201-10,200	10	120	20	40	80	74	6
10,201-12,200	12	120	20	45	75	68	6
12,201-14,200	14	130	22	45	85	78	6
14,201-15,200	16	130	22	48	82	75	6
15,201-16,200	16	150	25	48	102	95	6
16,201-18,200	18	150	25	48	102	95	6
18,201-20,200	20	150	25	50	100	92	6

* \leq d₁ 3.000 mm only IT7 possible.

Dimensions in mm.

For cutting data recommendations, see end of chapter.

HNC-Speed I B043261

Fixed design for blind bore, internal coolant supply

Design:

Diameter: 2.800 - 20.200 mm
 Cutting direction: Right-hand cutting
 Cutting material: Solid carbide, BSP-coated (HP145)
 Groove direction: Straight fluted
 Geometry: HPC, EU spacing

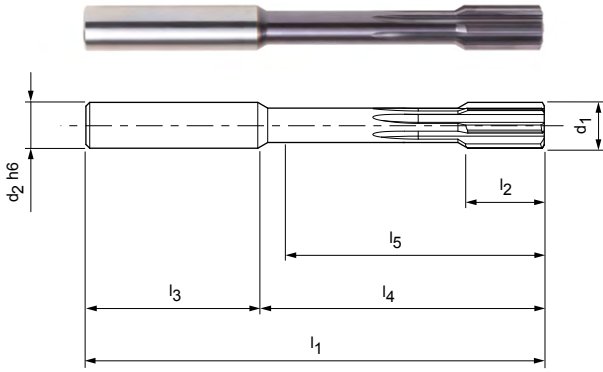

Preferred series available from stock in H7 | +0.004

Dimensions								z	Order no.
d_1	Tolerance	d_2 h6	l_1	l_2	l_3	l_4	l_5		
3,000	H7	4	65	12	28	37	33	4	30402456
3,200	H7	4	65	12	28	37	33	4	30402457
3,500	H7	4	65	12	28	37	33	4	30402458
3,970	+0,004	6	75	12	36	39	34	4	30131558
3,980	+0,004	6	75	12	36	39	34	4	30131560
3,990	+0,004	6	75	12	36	39	34	4	30131562
4,000	H7	6	75	12	36	39	34	4	30131564
4,010	+0,004	6	75	12	36	39	34	4	30131566
4,020	+0,004	6	75	12	36	39	34	4	30131568
4,030	+0,004	6	75	12	36	39	34	4	30131570
4,500	H7	6	75	12	36	39	34	4	30131572
4,970	+0,004	6	75	12	36	39	34	4	30131574
4,980	+0,004	6	75	12	36	39	34	4	30131576
4,990	+0,004	6	75	12	36	39	34	4	30131578
5,000	H7	6	75	12	36	39	34	4	30131580
5,010	+0,004	6	75	12	36	39	34	4	30131582
5,020	+0,004	6	75	12	36	39	34	4	30131584
5,030	+0,004	6	75	12	36	39	34	4	30131586
5,500	H7	6	75	12	36	39	34	4	30131588
5,970	+0,004	6	75	12	36	39	34	4	30131590
5,980	+0,004	6	75	12	36	39	34	4	30131592
5,990	+0,004	6	75	12	36	39	34	4	30131594
6,000	H7	6	75	12	36	39	34	4	30131596
6,010	+0,004	6	75	12	36	39	34	4	30131598
6,020	+0,004	6	75	12	36	39	34	4	30131600
6,030	+0,004	6	75	12	36	39	34	4	30131602
6,500	H7	8	100	16	36	64	58	6	30131604
7,000	H7	8	100	16	36	64	58	6	30131606
7,500	H7	8	100	16	36	64	58	6	30131608
7,970	+0,004	8	100	16	36	64	58	6	30131610
7,980	+0,004	8	100	16	36	64	58	6	30131612
7,990	+0,004	8	100	16	36	64	58	6	30131614
8,000	H7	8	100	16	36	64	58	6	30131616
8,010	+0,004	8	100	16	36	64	58	6	30131618
8,020	+0,004	8	100	16	36	64	58	6	30131620

HNC I B043261, fixed design for blind bore, internal coolant supply

Dimensions								z	Order no.
d ₁	Tolerance	d ₂ h6	l ₁	l ₂	l ₃	l ₄	l ₅		
8,030	+0,004	8	100	16	36	64	58	6	30131622
8,500	H7	10	100	20	40	60	54	6	30131624
9,000	H7	10	100	20	40	60	54	6	30131626
9,500	H7	10	120	20	40	80	74	6	30131628
9,970	+0,004	10	120	20	40	80	74	6	30131630
9,980	+0,004	10	120	20	40	80	74	6	30131632
9,990	+0,004	10	120	20	40	80	74	6	30131634
10,000	H7	10	120	20	40	80	74	6	30131636
10,010	+0,004	10	120	20	40	80	74	6	30131638
10,020	+0,004	10	120	20	40	80	74	6	30131640
10,030	+0,004	10	120	20	40	80	74	6	30131642
10,500	H7	12	120	20	45	75	68	6	30131644
11,000	H7	12	120	20	45	75	68	6	30131646
11,500	H7	12	120	20	45	75	68	6	30131648
11,970	+0,004	12	120	20	45	75	68	6	30131650
11,980	+0,004	12	120	20	45	75	68	6	30131652
11,990	+0,004	12	120	20	45	75	68	6	30131654
12,000	H7	12	120	20	45	75	68	6	30131656
12,010	+0,004	12	120	20	45	75	68	6	30131658
12,020	+0,004	12	120	20	45	75	68	6	30131660
12,030	+0,004	12	120	20	45	75	68	6	30131662
13,000	H7	14	130	22	45	85	78	6	30131664
14,000	H7	14	130	22	45	85	78	6	30131666
15,000	H7	16	130	22	48	82	75	6	30131668
16,000	H7	16	150	25	48	102	95	6	30131670
17,000	H7	18	150	25	48	102	95	6	30131672
18,000	H7	18	150	25	48	102	95	6	30131674
19,000	H7	20	150	25	50	100	92	6	30131676
20,000	H7	20	150	25	50	100	92	6	30131678

Configurable features

Bore diameter tolerance ≥ IT6:
 - Diameter in increments of 0.001 mm freely selectable
 - Can be ordered in tolerance ≥ IT6



Specification:
 B043261[**Diameter**][**Tolerance**]

G variant (see page 303):
 - Diameter in increments of 0.001 mm freely selectable
 - Can be ordered from tolerances ≥ 4 μm

G variant specification:
 B043261[**Diameter**][**Tolerance**]

IT6 tolerance example:
 B043261-**Ø016.350H6**

Bore diameter d₁ = 16.350 H6

G variant example:
 B043261-**Ø016.350-4**

Special tool diameter d₁ = 16.350 -4 μm

Dimensions of configurable series IT6

d ₁	d ₂	l ₁	l ₂	l ₃	l ₄	l ₅	z
2,800-3,700*	4	65	12	28	37	33	4
3,701-6,200	6	75	12	36	39	34	4
6,201-8,200	8	100	16	36	64	58	6
8,201-9,200	10	100	20	40	60	54	6
9,201-10,200	10	120	20	40	80	74	6
10,201-12,200	12	120	20	45	75	68	6
12,201-14,200	14	130	22	45	85	78	6
14,201-15,200	16	130	22	48	82	75	6
15,201-16,200	16	150	25	48	102	95	6
16,201-18,200	18	150	25	48	102	95	6
18,201-20,200	20	150	25	50	100	92	6

* ≤ d₁ 3.000 mm only IT7 possible.

Dimensions in mm.

For cutting data recommendations, see end of chapter.

HNC-VA | B043271

Fixed design for blind bore, internal coolant supply

Design:

Diameter:

2.800 - 20.200 mm

Cutting direction:

Right-hand cutting

Cutting material:

Solid carbide,
BVA-coated (HP145)

Groove direction:

Straight fluted

Geometry:

HPC, EU spacing

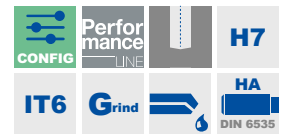
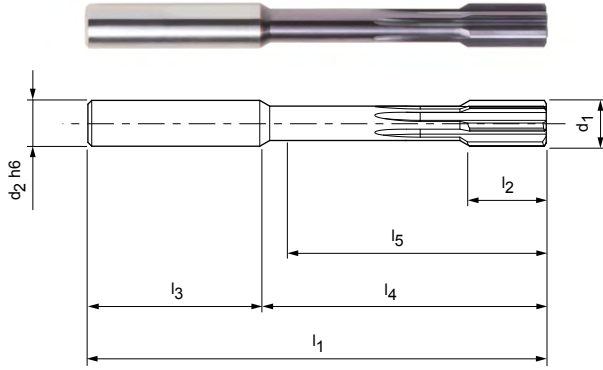

Preferred series available from stock in H7 | +0.004

Dimensions								z	Order no.
d_1	Tolerance	d_2 h6	l_1	l_2	l_3	l_4	l_5		
3,970	+0,004	6	75	12	36	39	34	4	30131802
3,980	+0,004	6	75	12	36	39	34	4	30131804
3,990	+0,004	6	75	12	36	39	34	4	30131806
4,000	H7	6	75	12	36	39	34	4	30131808
4,010	+0,004	6	75	12	36	39	34	4	30131810
4,020	+0,004	6	75	12	36	39	34	4	30131812
4,030	+0,004	6	75	12	36	39	34	4	30131814
4,500	H7	6	75	12	36	39	34	4	30131816
4,970	+0,004	6	75	12	36	39	34	4	30131818
4,980	+0,004	6	75	12	36	39	34	4	30131820
4,990	+0,004	6	75	12	36	39	34	4	30131822
5,000	H7	6	75	12	36	39	34	4	30131824
5,010	+0,004	6	75	12	36	39	34	4	30131826
5,020	+0,004	6	75	12	36	39	34	4	30131828
5,030	+0,004	6	75	12	36	39	34	4	30131830
5,500	H7	6	75	12	36	39	34	4	30131832
5,970	+0,004	6	75	12	36	39	34	4	30131834
5,980	+0,004	6	75	12	36	39	34	4	30131836
5,990	+0,004	6	75	12	36	39	34	4	30131838
6,000	H7	6	75	12	36	39	34	4	30131840
6,010	+0,004	6	75	12	36	39	34	4	30131842
6,020	+0,004	6	75	12	36	39	34	4	30131844
6,030	+0,004	6	75	12	36	39	34	4	30131846
6,500	H7	8	100	16	36	64	58	6	30131848
7,000	H7	8	100	16	36	64	58	6	30131850
7,500	H7	8	100	16	36	64	58	6	30131852
7,970	+0,004	8	100	16	36	64	58	6	30131854
7,980	+0,004	8	100	16	36	64	58	6	30131856
7,990	+0,004	8	100	16	36	64	58	6	30131858
8,000	H7	8	100	16	36	64	58	6	30131860
8,010	+0,004	8	100	16	36	64	58	6	30131862
8,020	+0,004	8	100	16	36	64	58	6	30131864
8,030	+0,004	8	100	16	36	64	58	6	30131866
8,500	H7	10	100	20	40	60	54	6	30131868
9,000	H7	10	100	20	40	60	54	6	30131870

HNC-VA I B043271, fixed design for blind bore, internal coolant supply

Dimensions								z	Order no.
d ₁	Tolerance	d ₂ h6	l ₁	l ₂	l ₃	l ₄	l ₅		
9,500	H7	10	120	20	40	80	74	6	30131872
9,970	+0,004	10	120	20	40	80	74	6	30131874
9,980	+0,004	10	120	20	40	80	74	6	30131876
9,990	+0,004	10	120	20	40	80	74	6	30131878
10,000	H7	10	120	20	40	80	74	6	30131880
10,010	+0,004	10	120	20	40	80	74	6	30131882
10,020	+0,004	10	120	20	40	80	74	6	30131884
10,030	+0,004	10	120	20	40	80	74	6	30131886
10,500	H7	12	120	20	45	75	68	6	30131888
11,000	H7	12	120	20	45	75	68	6	30131890
11,500	H7	12	120	20	45	75	68	6	30131892
11,970	+0,004	12	120	20	45	75	68	6	30131894
11,980	+0,004	12	120	20	45	75	68	6	30131896
11,990	+0,004	12	120	20	45	75	68	6	30131898
12,000	H7	12	120	20	45	75	68	6	30131900
12,010	+0,004	12	120	20	45	75	68	6	30131902
12,020	+0,004	12	120	20	45	75	68	6	30131904
12,030	+0,004	12	120	20	45	75	68	6	30131906
13,000	H7	14	130	22	45	85	78	6	30131908
14,000	H7	14	130	22	45	85	78	6	30131910
15,000	H7	16	130	22	48	82	75	6	30131912
16,000	H7	16	150	25	48	102	95	6	30131914
17,000	H7	18	150	25	48	102	95	6	30131916
18,000	H7	18	150	25	48	102	95	6	30131918
19,000	H7	20	150	25	50	100	92	6	30131920
20,000	H7	20	150	25	50	100	92	6	30131922

Configurable features



Bore diameter tolerance \geq IT6:
 - Diameter in increments of 0.001 mm freely selectable
 - Can be ordered in tolerance \geq IT6



Specification:
 B043271[**Diameter**][**Tolerance**]

G variant (see page 303):
 - Diameter in increments of 0.001 mm freely selectable
 - Can be ordered from tolerances \geq 4 μ m

G variant specification:
 B043271[**Diameter**][**Tolerance**]

IT6 tolerance example:
 B043271-**0016.350H6**

Bore diameter d₁ = 16.350 H6

G variant example:
 B043271-**0016.350-4**

Special tool diameter d₁ = 16.350 -4 μ m

Dimensions of configurable series IT6

d ₁	d ₂	l ₁	l ₂	l ₃	l ₄	l ₅	z
2,800-3,700*	4	65	12	28	37	33	4
3,701-6,200	6	75	12	36	39	34	4
6,201-8,200	8	100	16	36	64	58	6
8,201-9,200	10	100	20	40	60	54	6
9,201-10,200	10	120	20	40	80	74	6
10,201-12,200	12	120	20	45	75	68	6
12,201-14,200	14	130	22	45	85	78	6
14,201-15,200	16	130	22	48	82	75	6
15,201-16,200	16	150	25	48	102	95	6
16,201-18,200	18	150	25	48	102	95	6
18,201-20,200	20	150	25	50	100	92	6

* \leq d₁ 3.000 mm only IT7 possible.

HNC-TI | B043273

Fixed design for blind bore, internal coolant supply

Design:

Diameter:

2.800 - 20.200 mm

Cutting direction:

Right-hand cutting

Cutting material:

Solid carbide,
BTI-coated (HP625)

Groove direction:

Straight fluted

Geometry:

HPC, EU spacing

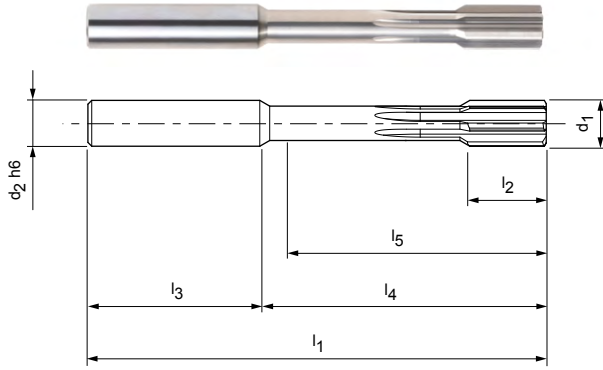

Preferred series available from stock in H7 | +0.004

Dimensions								z	Order no.
d ₁	Tolerance	d ₂ h6	l ₁	l ₂	l ₃	l ₄	l ₅		
3,970	+0,004	6	75	12	36	39	34	4	30585314
3,980	+0,004	6	75	12	36	39	34	4	30585315
3,990	+0,004	6	75	12	36	39	34	4	30585316
4,000	H7	6	75	12	36	39	34	4	30585289
4,010	+0,004	6	75	12	36	39	34	4	30585317
4,020	+0,004	6	75	12	36	39	34	4	30585318
4,030	+0,004	6	75	12	36	39	34	4	30585319
4,500	H7	6	75	12	36	39	34	4	30585290
4,970	+0,004	6	75	12	36	39	34	4	30585320
4,980	+0,004	6	75	12	36	39	34	4	30585321
4,990	+0,004	6	75	12	36	39	34	4	30585322
5,000	H7	6	75	12	36	39	34	4	30585291
5,010	+0,004	6	75	12	36	39	34	4	30585323
5,020	+0,004	6	75	12	36	39	34	4	30585324
5,030	+0,004	6	75	12	36	39	34	4	30585325
5,500	H7	6	75	12	36	39	34	4	30585292
5,970	+0,004	6	75	12	36	39	34	4	30585326
5,980	+0,004	6	75	12	36	39	34	4	30585327
5,990	+0,004	6	75	12	36	39	34	4	30585328
6,000	H7	6	75	12	36	39	34	4	30585293
6,010	+0,004	6	75	12	36	39	34	4	30585329
6,020	+0,004	6	75	12	36	39	34	4	30585330
6,030	+0,004	6	75	12	36	39	34	4	30585331
6,500	H7	8	100	16	36	64	58	6	30585294
7,000	H7	8	100	16	36	64	58	6	30585295
7,500	H7	8	100	16	36	64	58	6	30585296
7,970	+0,004	8	100	16	36	64	58	6	30585332
7,980	+0,004	8	100	16	36	64	58	6	30585333
7,990	+0,004	8	100	16	36	64	58	6	30585334
8,000	H7	8	100	16	36	64	58	6	30585297
8,010	+0,004	8	100	16	36	64	58	6	30585335
8,020	+0,004	8	100	16	36	64	58	6	30585336
8,030	+0,004	8	100	16	36	64	58	6	30585337
8,500	H7	10	100	20	40	60	54	6	30585298
9,000	H7	10	100	20	40	60	54	6	30585299

HNC-TI | B043273, fixed design for blind bore, internal coolant supply

Dimensions								z	Order no.
d ₁	Tolerance	d ₂ h6	l ₁	l ₂	l ₃	l ₄	l ₅		
9,500	H7	10	120	20	40	80	74	6	30585300
9,970	+0,004	10	120	20	40	80	74	6	30585338
9,980	+0,004	10	120	20	40	80	74	6	30585339
9,990	+0,004	10	120	20	40	80	74	6	30585340
10,000	H7	10	120	20	40	80	74	6	30585301
10,010	+0,004	10	120	20	40	80	74	6	30585341
10,020	+0,004	10	120	20	40	80	74	6	30585342
10,030	+0,004	10	120	20	40	80	74	6	30585343
10,500	H7	12	120	20	45	75	68	6	30585302
11,000	H7	12	120	20	45	75	68	6	30585303
11,500	H7	12	120	20	45	75	68	6	30585304
11,970	+0,004	12	120	20	45	75	68	6	30585344
11,980	+0,004	12	120	20	45	75	68	6	30585345
11,990	+0,004	12	120	20	45	75	68	6	30585346
12,000	H7	12	120	20	45	75	68	6	30585305
12,010	+0,004	12	120	20	45	75	68	6	30585347
12,020	+0,004	12	120	20	45	75	68	6	30585348
12,030	+0,004	12	120	20	45	75	68	6	30585349
13,000	H7	14	130	22	45	85	78	6	30585306
14,000	H7	14	130	22	45	85	78	6	30585307
15,000	H7	16	130	22	48	82	75	6	30585308
16,000	H7	16	150	25	48	102	95	6	30585309
17,000	H7	18	150	25	48	102	95	6	30585310
18,000	H7	18	150	25	48	102	95	6	30585311
19,000	H7	20	150	25	50	100	92	6	30585312
20,000	H7	20	150	25	50	100	92	6	30585313

Configurable features

Bore diameter tolerance ≥ IT6:
 - Diameter in increments of 0.001 mm freely selectable
 - Can be ordered in tolerance ≥ IT6



Specification:
 B043273[**Diameter**][**Tolerance**]

G variant (see page 303):
 - Diameter in increments of 0.001 mm freely selectable
 - Can be ordered from tolerances ≥ 4 μm

G variant specification:
 B043273[**Diameter**][**Tolerance**]

IT6 tolerance example:
 B043273-~~00~~**16.350H6**

Bore diameter d₁ = 16.350 H6

G variant example:
 B043273-~~00~~**16.350-4**

Special tool diameter d₁ = 16.350 -4 μm

Dimensions of configurable series IT6

d ₁	d ₂	l ₁	l ₂	l ₃	l ₄	l ₅	z
2,800-3,700*	4	65	12	28	37	33	4
3,701-6,200	6	75	12	36	39	34	4
6,201-8,200	8	100	16	36	64	58	6
8,201-9,200	10	100	20	40	60	54	6
9,201-10,200	10	120	20	40	80	74	6
10,201-12,200	12	120	20	45	75	68	6
12,201-14,200	14	130	22	45	85	78	6
14,201-15,200	16	130	22	48	82	75	6
15,201-16,200	16	150	25	48	102	95	6
16,201-18,200	18	150	25	48	102	95	6
18,201-20,200	20	150	25	50	100	92	6

* ≤ d₁ 3.000 mm only IT7 possible.

Dimensions in mm.

For cutting data recommendations, see end of chapter.

HNC-Diamond I B043291

Fixed design for blind bore, internal coolant supply

Design:

Diameter: 2.800 - 20.200 mm
 Cutting direction: Right-hand cutting
 Cutting material: Solid carbide, diamond-coated (HC614)
 Groove direction: Straight fluted
 Geometry: HPC, EU spacing

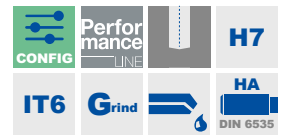
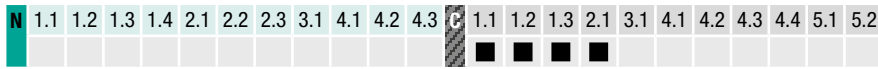
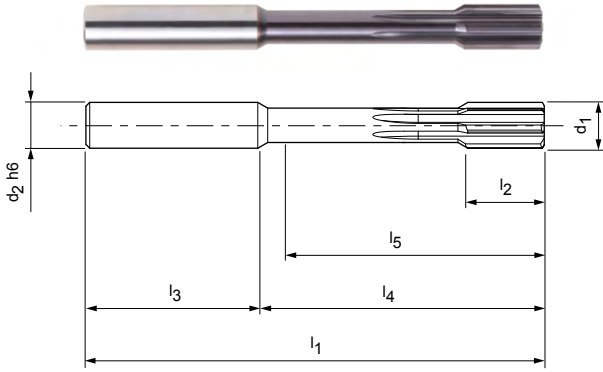

Preferred series in H7

Dimensions							z	Order no.
d_1 H7	d_2 h6	l_1	l_2	l_3	l_4	l_5		
4,000	6	75	12	36	39	34	4	30601845
4,500	6	75	12	36	39	34	4	30495398
5,000	6	75	12	36	39	34	4	30601846
5,500	6	75	12	36	39	34	4	30601847
6,000	6	75	12	36	39	34	4	30498850
6,500	8	100	16	36	64	58	6	30601848
7,000	8	100	16	36	64	58	6	30601849
7,500	8	100	16	36	64	58	6	30601850
8,000	8	100	16	36	64	58	6	30546131
8,500	10	100	20	40	60	54	6	30601851
9,000	10	100	20	40	60	54	6	30601852
9,500	10	120	20	40	80	74	6	30601853
10,000	10	120	20	40	80	74	6	30419221
10,500	12	120	20	45	75	68	6	30601854
11,000	12	120	20	45	75	68	6	30601855
11,500	12	120	20	45	75	68	6	30601856
12,000	12	120	20	45	75	68	6	30466230
13,000	14	130	22	45	85	78	6	30601857
14,000	14	130	22	45	85	78	6	30601858
15,000	16	130	22	48	82	75	6	30601859
16,000	16	150	25	48	102	95	6	30601860
17,000	18	150	25	48	102	95	6	30601861
18,000	18	150	25	48	102	95	6	30601862
19,000	20	150	25	50	100	92	6	30601863
20,000	20	150	25	50	100	92	6	30497749

Configurable features

**Bore diameter tolerance \geq IT6:**

- Diameter in increments of 0.001 mm freely selectable
- Can be ordered in tolerance \geq IT6

**Specification:**

B043291[Diameter][Tolerance]

G variant (see page 303):

- Diameter in increments of 0.001 mm freely selectable
- Can be ordered from tolerances $\geq 4 \mu\text{m}$

G variant specification:

B043291[Diameter][Tolerance]

IT6 tolerance example:

B043291-0016.350H6

Bore diameter $d_1 = 16.350 \text{ H6}$ **G variant example:**

B043291-0016.350-4

Special tool diameter $d_1 = 16.350 -4 \mu\text{m}$

Dimensions of configurable series IT6

d_1	d_2	l_1	l_2	l_3	l_4	l_5	z
2,800-3,700*	4	65	12	28	37	33	4
3,701-6,200	6	75	12	36	39	34	4
6,201-8,200	8	100	16	36	64	58	6
8,201-9,200	10	100	20	40	60	54	6
9,201-10,200	10	120	20	40	80	74	6
10,201-12,200	12	120	20	45	75	68	6
12,201-14,200	14	130	22	45	85	78	6
14,201-15,200	16	130	22	48	82	75	6
15,201-16,200	16	150	25	48	102	95	6
16,201-18,200	18	150	25	48	102	95	6
18,201-20,200	20	150	25	50	100	92	6

* $\leq d_1$ 3.000 mm only IT7 possible.

HNC-AL | B043251

Fixed design for blind bore, internal coolant supply

Design:

Diameter: 2.800 - 20.200 mm
 Cutting direction: Right-hand cutting
 Cutting material: Solid carbide, BAL-coated (HP622)
 Groove direction: Straight fluted
 Geometry: HPC, EU spacing

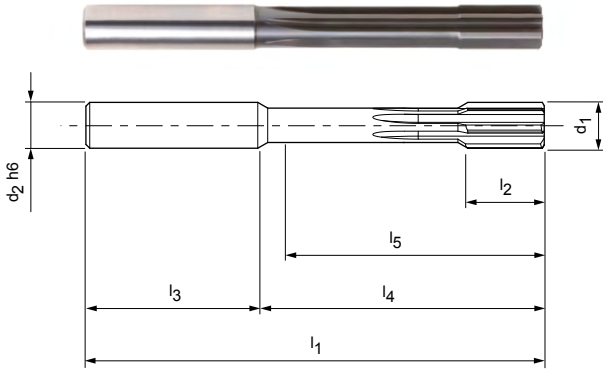

Preferred series in H7

Dimensions							z	Order no.
d_1 H7	d_2 h6	l_1	l_2	l_3	l_4	l_5		
4,000	6	75	12	36	39	34	4	30385429
4,500	6	75	12	36	39	34	4	30385431
5,000	6	75	12	36	39	34	4	30385433
5,500	6	75	12	36	39	34	4	30385434
6,000	6	75	12	36	39	34	4	30385436
6,500	8	100	16	36	64	58	6	30385439
7,000	8	100	16	36	64	58	6	30385440
7,500	8	100	16	36	64	58	6	30385441
8,000	8	100	16	36	64	58	6	30385442
8,500	10	100	20	40	60	54	6	30385443
9,000	10	100	20	40	60	54	6	30385444
9,500	10	120	20	40	80	74	6	30385445
10,000	10	120	20	40	80	74	6	30385446
10,500	12	120	20	45	75	68	6	30385447
11,000	12	120	20	45	75	68	6	30385449
11,500	12	120	20	45	75	68	6	30385451
12,000	12	120	20	45	75	68	6	30385452
13,000	14	130	22	45	85	78	6	30385453
14,000	14	130	22	45	85	78	6	30385454
15,000	16	130	22	48	82	75	6	30385455
16,000	16	150	25	48	102	95	6	30385456
17,000	18	150	25	48	102	95	6	30385458
18,000	18	150	25	48	102	95	6	30385460
19,000	20	150	25	50	100	92	6	30385461
20,000	20	150	25	50	100	92	6	30385464

Configurable features



Bore diameter tolerance \geq IT6:
 - Diameter in increments of 0.001 mm freely selectable
 - Can be ordered in tolerance \geq IT6



Specification:
 B043251[Diameter][Tolerance]

G variant (see page 303):
 - Diameter in increments of 0.001 mm freely selectable
 - Can be ordered from tolerances $\geq 4 \mu\text{m}$

G variant specification:
 B043251[Diameter][Tolerance]

IT6 tolerance example:
 B043251-~~00~~16.350H6

Bore diameter $d_1 = 16.350 \text{ H6}$

G variant example:
 B043251-~~00~~16.350-4

Special tool diameter $d_1 = 16.350 -4 \mu\text{m}$

Dimensions of configurable series IT6

d_1	d_2	l_1	l_2	l_3	l_4	l_5	z
2,800-3,700*	4	65	12	28	37	33	4
3,701-6,200	6	75	12	36	39	34	4
6,201-8,200	8	100	16	36	64	58	6
8,201-9,200	10	100	20	40	60	54	6
9,201-10,200	10	120	20	40	80	74	6
10,201-12,200	12	120	20	45	75	68	6
12,201-14,200	14	130	22	45	85	78	6
14,201-15,200	16	130	22	48	82	75	6
15,201-16,200	16	150	25	48	102	95	6
16,201-18,200	18	150	25	48	102	95	6
18,201-20,200	20	150	25	50	100	92	6

* $\leq d_1$ 3,000 mm only IT7 possible.

HNC-HT | B043281

Fixed design for blind bore, internal coolant supply

Design:

Diameter: 2.800 - 20.200 mm
 Cutting direction: Right-hand cutting
 Cutting material: Solid carbide, BHV-coated (HP141)
 Groove direction: Straight fluted
 Geometry: HPC, EU spacing
 Hardness level: Up to 60 HRC

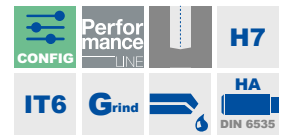
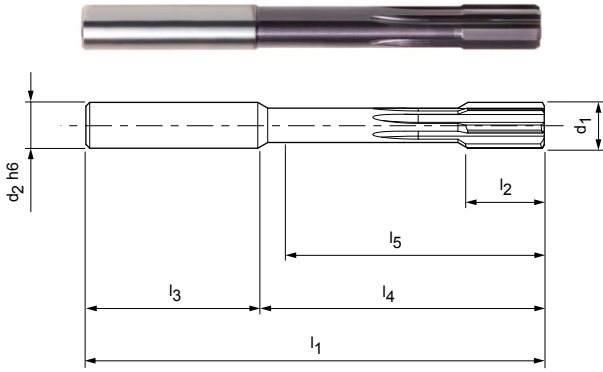

Preferred series available from stock in H7 | +0.004

Dimensions								z	Order no.
d_1	Tolerance	$d_2 \text{ h6}$	l_1	l_2	l_3	l_4	l_5		
3,970	+0,004	6	75	12	36	39	34	4	30301217
3,980	+0,004	6	75	12	36	39	34	4	30301219
3,990	+0,004	6	75	12	36	39	34	4	30301220
4,000	H7	6	75	12	36	39	34	4	30301222
4,010	+0,004	6	75	12	36	39	34	4	30301223
4,020	+0,004	6	75	12	36	39	34	4	30301224
4,030	+0,004	6	75	12	36	39	34	4	30301225
4,500	H7	6	75	12	36	39	34	4	30301226
4,970	+0,004	6	75	12	36	39	34	4	30301227
4,980	+0,004	6	75	12	36	39	34	4	30301228
4,990	+0,004	6	75	12	36	39	34	4	30301229
5,000	H7	6	75	12	36	39	34	4	30301234
5,010	+0,004	6	75	12	36	39	34	4	30301236
5,020	+0,004	6	75	12	36	39	34	4	30301237
5,030	+0,004	6	75	12	36	39	34	4	30301365
5,500	H7	6	75	12	36	39	34	4	30301366
5,970	+0,004	6	75	12	36	39	34	4	30301369
5,980	+0,004	6	75	12	36	39	34	4	30301372
5,990	+0,004	6	75	12	36	39	34	4	30301373
6,000	H7	6	75	12	36	39	34	4	30301374
6,010	+0,004	6	75	12	36	39	34	4	30301375
6,020	+0,004	6	75	12	36	39	34	4	30301376
6,030	+0,004	6	75	12	36	39	34	4	30301377
6,500	H7	8	100	16	36	64	58	6	30301378
7,000	H7	8	100	16	36	64	58	6	30301379
7,500	H7	8	100	16	36	64	58	6	30301380
7,970	+0,004	8	100	16	36	64	58	6	30301381
7,980	+0,004	8	100	16	36	64	58	6	30301382
7,990	+0,004	8	100	16	36	64	58	6	30301383
8,000	H7	8	100	16	36	64	58	6	30228281
8,010	+0,004	8	100	16	36	64	58	6	30301384
8,020	+0,004	8	100	16	36	64	58	6	30301387
8,030	+0,004	8	100	16	36	64	58	6	30301388
8,500	H7	10	100	20	40	60	54	6	30301389
9,000	H7	10	100	20	40	60	54	6	30301390

HNC-HT I B043281, fixed design for blind bore, internal coolant supply

Dimensions								z	Order no.
d ₁	Tolerance	d ₂ h6	l ₁	l ₂	l ₃	l ₄	l ₅		
9,500	H7	10	120	20	40	80	74	6	30301391
9,970	+0,004	10	120	20	40	80	74	6	30301392
9,980	+0,004	10	120	20	40	80	74	6	30301393
9,990	+0,004	10	120	20	40	80	74	6	30301394
10,000	H7	10	120	20	40	80	74	6	30301395
10,010	+0,004	10	120	20	40	80	74	6	30301398
10,020	+0,004	10	120	20	40	80	74	6	30301399
10,030	+0,004	10	120	20	40	80	74	6	30301400
10,500	H7	12	120	20	45	75	68	6	30301401
11,000	H7	12	120	20	45	75	68	6	30301402
11,500	H7	12	120	20	45	75	68	6	30301403
11,970	+0,004	12	120	20	45	75	68	6	30301404
11,980	+0,004	12	120	20	45	75	68	6	30301405
11,990	+0,004	12	120	20	45	75	68	6	30301406
12,000	H7	12	120	20	45	75	68	6	30228282
12,010	+0,004	12	120	20	45	75	68	6	30301452
12,020	+0,004	12	120	20	45	75	68	6	30301453
12,030	+0,004	12	120	20	45	75	68	6	30301455
13,000	H7	14	130	22	45	85	78	6	30301456
14,000	H7	14	130	22	45	85	78	6	30301457
15,000	H7	16	130	22	48	82	75	6	30301465
16,000	H7	16	150	25	48	102	95	6	30228283
17,000	H7	18	150	25	48	102	95	6	30301467
18,000	H7	18	150	25	48	102	95	6	30301470
19,000	H7	20	150	25	50	100	92	6	30301499
20,000	H7	20	150	25	50	100	92	6	30301500

Configurable features



Bore diameter tolerance \geq IT6:
 - Diameter in increments of 0.001 mm freely selectable
 - Can be ordered in tolerance \geq IT6



Specification:
 B043281[**Diameter**][**Tolerance**]

G variant (see page 303):
 - Diameter in increments of 0.001 mm freely selectable
 - Can be ordered from tolerances \geq 4 μ m

G variant specification:
 B043281[**Diameter**][**Tolerance**]

IT6 tolerance example:
 B043281-**0016.350H6**

Bore diameter d₁ = 16.350 H6

G variant example:
 B043281-**0016.350-4**

Special tool diameter d₁ = 16.350 -4 μ m

Dimensions of configurable series IT6

d ₁	d ₂	l ₁	l ₂	l ₃	l ₄	l ₅	z
2,800-3,700*	4	65	12	28	37	33	4
3,701-6,200	6	75	12	36	39	34	4
6,201-8,200	8	100	16	36	64	58	6
8,201-9,200	10	100	20	40	60	54	6
9,201-10,200	10	120	20	40	80	74	6
10,201-12,200	12	120	20	45	75	68	6
12,201-14,200	14	130	22	45	85	78	6
14,201-15,200	16	130	22	48	82	75	6
15,201-16,200	16	150	25	48	102	95	6
16,201-18,200	18	150	25	48	102	95	6
18,201-20,200	20	150	25	50	100	92	6

* \leq d₁ 3.000 mm only IT7 possible.

PcBN reamer I B040366

Fixed design for blind bore, internal coolant supply

Design:

Diameter:

Cutting direction:

Cutting material:

Groove direction:

Geometry:

Hardness level:

3.000 - 10.200 mm

Right-hand cutting

PcBN head

Straight fluted

HPC, EU spacing

Up to 68 HRC

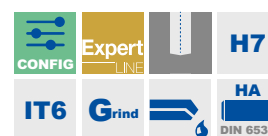
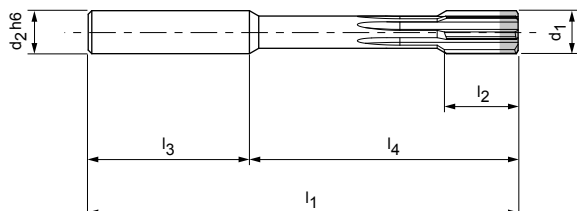

Preferred series in H7

Dimensions						z	Order no.
d ₁ H7	d ₂ h6	l ₁	l ₂	l ₃	l ₄		
3,000	4	65	12	28	37	6	30601813
3,500	4	65	12	28	37	6	30601814
4,000	6	75	12	36	39	6	30601815
4,500	6	75	12	36	39	6	30601816
5,000	6	75	12	36	39	6	30601817
5,500	6	75	12	36	39	6	30601818
6,000	6	75	12	36	39	8	30601819
6,500	8	100	16	36	64	8	30601820
7,000	8	100	16	36	64	8	30601821
7,500	8	100	16	36	64	8	30601822
8,000	8	100	16	36	64	10	30601823
8,500	10	100	16	40	60	10	30601824
9,000	10	100	16	40	60	10	30601825
9,500	10	120	20	40	80	10	30601826
10,000	10	120	20	40	80	10	30601827

Configurable features

**Bore diameter tolerance \geq IT6:**

- Diameter in increments of 0.001 mm freely selectable
- Can be ordered in tolerance \geq IT6

**Specification:**

B040366[Diameter][Tolerance]

G variant (see page 303):

- Diameter in increments of 0.001 mm freely selectable
- Can be ordered from tolerances $\geq 3 \mu\text{m}$

G variant specification:

B040366[Diameter][Tolerance]

IT6 tolerance example:B040366-~~008.350~~H6Bore diameter $d_1 = 8.350 \text{ H6}$ **G variant example:**B040366-~~008.350~~-3Special tool diameter $d_1 = 8.350 -3 \mu\text{m}$

Dimensions of configurable series IT6

d_1	$d_2 \text{ h6}$	l_1	l_2	l_3	l_4	z
3,001-3,710	4	65	12	28	37	6
3,711-5,710	6	75	12	36	39	6
5,711-6,210	6	75	12	36	39	8
6,211-7,710	8	100	16	36	64	8
7,711-8,210	8	100	16	36	64	10
8,211-9,210	10	100	16	40	60	10
9,211-10,200	10	120	20	40	80	10

HNC-Short | B043265

Fixed design for blind bore, internal coolant supply

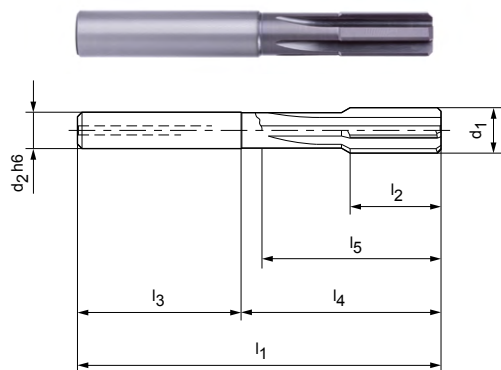

Design:

Diameter: 2.800 - 20.100 mm
 Cutting direction: Right-hand cutting
 Cutting material: Solid carbide, BSP-coated (HP145)
 Groove direction: Straight fluted
 Geometry: HPC, EU spacing
 Special feature: Suitable for machining on automated lathes, for short bores

Note:

Suitable in some situations for through bores (external cooling required).

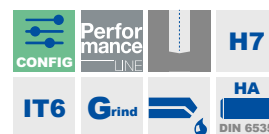

Preferred series in H7

Dimensions							z	Order no.
d_1 H7	d_2 h6	l_1	l_2	l_3	l_4	l_5		
3,000	4	56	12	28	28	24	4	30400036
3,200	4	56	12	28	28	24	4	30400035
3,500	4	56	12	28	28	24	4	30400037
4,000	4	56	12	28	28	24	4	30400038
4,500	6	64	12	36	28	23	4	30400039
5,000	6	64	12	36	28	23	4	30357266
5,500	6	64	12	36	28	24	4	30400040
6,000	6	64	12	36	28	25	4	30356948
6,500	8	75	16	36	39	32	6	30395323
7,000	8	75	16	36	39	34	6	30400043
7,500	8	75	16	36	39	35	6	30400044
8,000	8	75	16	36	39	35	6	30356949
8,500	8	75	20	36	39	35	6	30400046
9,000	8	75	20	36	39	35	6	30400050
9,500	8	75	20	36	39	35	6	30400051
10,000	8	75	20	36	39	35	6	30356951
10,500	10	80	20	40	40	35	6	30400053
11,000	10	80	20	40	40	35	6	30400054
11,500	10	80	20	40	40	35	6	30400055
12,000	12	90	22	45	45	40	6	30356952
13,000	12	90	22	45	45	40	6	30400057
14,000	14	90	22	45	45	40	6	30400058
15,000	14	90	22	45	45	40	6	30400059
16,000	16	100	25	48	52	47	8	30400060
17,000	16	100	25	48	52	47	8	30400061
18,000	16	100	25	48	52	47	8	30384786
19,000	18	100	25	48	52	47	8	30400062
20,000	18	100	25	48	52	47	8	30400063

Configurable features



Bore diameter tolerance \geq IT6:
 - Diameter in increments of 0.001 mm freely selectable
 - Can be ordered in tolerance \geq IT6



Specification:
 B043265[Diameter][Tolerance]

G variant (see page 303):
 - Diameter in increments of 0.001 mm freely selectable
 - Can be ordered from tolerances $\geq 4 \mu\text{m}$

G variant specification:
 B043265[Diameter][Tolerance]

IT6 tolerance example:
 B043265-~~00~~16.350H6

Bore diameter $d_1 = 16.350 \text{ H6}$

G variant example:
 B043265-~~00~~16.350-4

Special tool diameter $d_1 = 16.350 -4 \mu\text{m}$

Dimensions of configurable series IT6

d_1	d_2	l_1	l_2	l_3	l_4	l_5	z
2,800-4,050*	4	56	12	28	28	24	4
4,051-5,100	6	64	12	36	28	23	4
5,101-5,600	6	64	12	36	28	24	4
5,601-6,100	6	64	12	36	28	25	4
6,101-8,100	8	75	16	36	39	32	6
8,101-10,100	8	75	20	36	39	35	6
10,101-11,600	10	80	20	40	40	35	6
11,601-13,100	12	90	22	45	45	40	6
13,101-15,100	14	90	22	45	45	40	6
15,101-18,100	16	100	25	48	52	47	8
18,101-20,100	18	100	25	48	52	47	8

* $\leq d_1$ 3,000 mm only IT7 possible.

FixReam 700 | B042200

Expanding design, short, for through bore

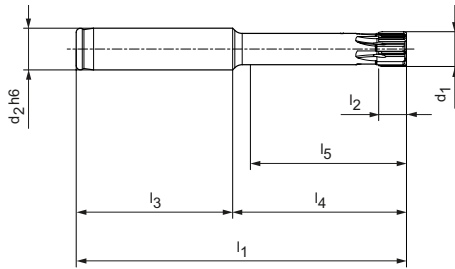

Design:
 Diameter: 9.900 - 32.200 mm
 Cutting direction: Right-hand cutting
 Cutting material: Cermet uncoated (CU111)
 Groove direction: Straight fluted

Application:
 The expansion system is therefore only suitable for compensation prior to re-grinding and not for setting or re-adjusting the diameter.

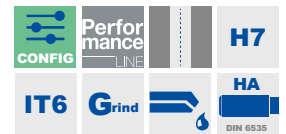

Preferred series in H7

d ₁ H7	Dimensions						z	Order no.
	d ₂ h6	l ₁	l ₂	l ₃	l ₄	l ₅		
10,000	12	95	8	45	50	45	6	31449002
12,000	12	95	8	45	50	45	6	31449003
14,000	12	95	8	45	50	45	6	31449004
16,000	16	100	12	50	50	45	6	31449005
18,000	16	100	12	50	50	45	6	31449006
20,000	20	120	12	60	60	55	6	31449007
22,000	20	120	12	60	60	55	6	31449008
24,000	20	120	12	60	60	55	6	31449009
25,000	20	120	12	60	60	55	6	31449030
28,000	25	135	12	60	75	70	6	31449032
30,000	25	135	12	60	75	70	6	31449033
32,000	25	135	12	60	75	70	6	31449034

Configurable features



Bore diameter tolerance ≥ IT6:
 - Diameter in increments of 0.001 mm freely selectable
 - Can be ordered in tolerance ≥ IT6

Specification:
 B042200@[Diameter][Tolerance]

G variant (see page 303):
 - Diameter in increments of 0.001 mm freely selectable
 - Can be ordered from tolerances ≥ 3 μm (G variant, see cutting data)

G variant specification:
 B042200@[Diameter][Tolerance]

Dimensions of configurable series IT6

d ₁	d ₂	l ₁	l ₂	l ₃	l ₄	l ₅	z
9,900 - 15,899	12	95	8	45	50	45	6
15,900 - 18,899	16	100	12	50	50	45	6
18,900 - 25,899	20	120	12	60	60	55	6
25,900 - 32,200	25	135	12	60	75	70	6

IT6 tolerance example:
 B042200@16.350H6

Bore diameter d₁ = 16.350 H6

G variant example:
 B042200@16.350-3

Special tool diameter d₁ = 16.350 -3 μm

Dimensions in mm.
 For cutting data recommendations, see end of chapter.

FixReam 700 | B042700

Expanding design, long, for through bore

Design:

Diameter: 9.900 - 32.200 mm
 Cutting direction: Right-hand cutting
 Cutting material: Cermet uncoated (CU111)
 Groove direction: Straight fluted

Application:

The expansion system is therefore only suitable for compensation prior to re-grinding and not for setting or re-adjusting the diameter.

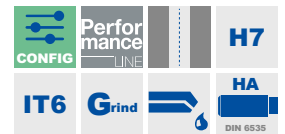
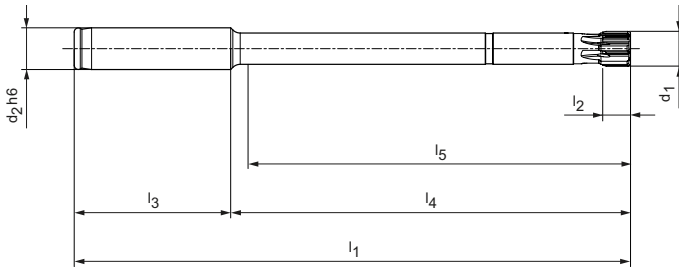

Preferred series in H7

d ₁ H7	Dimensions						z	Order no.
	d ₂ h6	l ₁	l ₂	l ₃	l ₄	l ₅		
10,000	12	160	8	45	115	110	6	31449035
12,000	12	160	8	45	115	110	6	31449036
14,000	12	160	8	45	115	110	6	31449037
16,000	16	180	12	50	130	125	6	31449038
18,000	16	180	12	50	130	125	6	31449039
20,000	20	200	12	60	140	135	6	31449040
22,000	20	200	12	60	140	135	6	31449041
24,000	20	200	12	60	140	135	6	31449042
25,000	20	200	12	60	140	135	6	31449043
28,000	25	210	12	60	150	145	6	31449045
30,000	25	210	12	60	150	145	6	31449046
32,000	25	210	12	60	150	145	6	31449047

Configurable features



Bore diameter tolerance ≥ IT6:
 - Diameter in increments of 0.001 mm freely selectable
 - Can be ordered in tolerance ≥ IT6

Specification:
 B042700@[Diameter][Tolerance]

G variant (see page 303):
 - Diameter in increments of 0.001 mm freely selectable
 - Can be ordered from tolerances ≥ 3 μm (G variant, see cutting data)

G variant specification:
 B042700@[Diameter][Tolerance]

Dimensions of configurable series IT6

d ₁	d ₂	l ₁	l ₂	l ₃	l ₄	l ₅	z
9,900 - 15,899	12	160	8	45	115	110	6
15,900 - 18,899	16	180	12	50	130	125	6
18,900 - 25,899	20	200	12	60	140	135	6
25,900 - 32,200	25	210	12	60	150	145	6

IT6 tolerance example:
 B042700@16.350H6

Bore diameter d₁ = 16.350 H6

G variant example:
 B042700@16.350-3

Special tool diameter d₁ = 16.350 -3 μm

Dimensions in mm.
 For cutting data recommendations, see end of chapter.

FixReam 700 | B042201

Expanding design, short, for blind bore

Design:

Diameter: 9.900 - 32.200 mm
 Cutting direction: Right-hand cutting
 Cutting material: Cermet uncoated (CU111)
 Groove direction: Straight fluted

Application:

The expansion system is therefore only suitable for compensation prior to re-grinding and not for setting or re-adjusting the diameter.

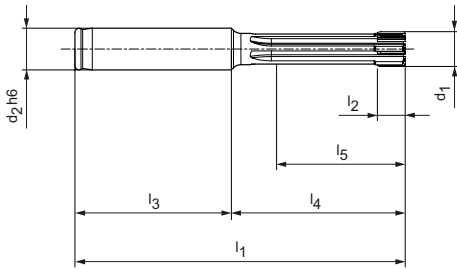

Preferred series in H7

d ₁ H7	Dimensions						z	Order no.
	d ₂ h6	l ₁	l ₂	l ₃	l ₄	l ₅		
10,000	12	95	8	45	50	38	6	31449048
12,000	12	95	8	45	50	39	6	31449049
14,000	12	95	8	45	50	39	6	31449050
16,000	16	100	12	50	50	38	6	31449051
18,000	16	100	12	50	50	39	6	31449052
20,000	20	120	12	60	60	45	6	31449053
22,000	20	120	12	60	60	45	6	31449054
24,000	20	120	12	60	60	45	6	31449055
25,000	20	120	12	60	60	45	6	31449056
28,000	25	135	12	60	75	60	6	31449058
30,000	25	135	12	60	75	60	6	31449059
32,000	25	135	12	60	75	60	6	31449060

Configurable features



Bore diameter tolerance ≥ IT6:
 - Diameter in increments of 0.001 mm freely selectable
 - Can be ordered in tolerance ≥ IT6

Specification:
 B042201Ø[Diameter][Tolerance]

G variant (see page 303):
 - Diameter in increments of 0.001 mm freely selectable
 - Can be ordered from tolerances ≥ 3 µm (G variant, see cutting data)

G variant specification:
 B042201Ø[Diameter][Tolerance]

Dimensions of configurable series IT6

d ₁	d ₂	l ₁	l ₂	l ₃	l ₄	l ₅	z
9,900 - 15,899	12	95	8	45	50	38	6
15,900 - 18,899	16	100	12	50	50	38	6
18,900 - 25,899	20	120	12	60	60	45	6
25,900 - 32,200	25	135	12	60	75	60	6

IT6 tolerance example:
 B042201Ø16.350H6

Bore diameter d₁ = 16.350 H6

G variant example:
 B042201Ø16.350-3

Special tool diameter d₁ = 16.350 -3 µm

Dimensions in mm.

For cutting data recommendations, see end of chapter.

FixReam 700 | B042701

Expanding design, long, for blind bore

Design:

Diameter: 9.900 - 32.200 mm
 Cutting direction: Right-hand cutting
 Cutting material: Cermet uncoated (CU111)
 Groove direction: Straight fluted

Application:

The expansion system is therefore only suitable for compensation prior to re-grinding and not for setting or re-adjusting the diameter.

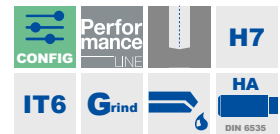
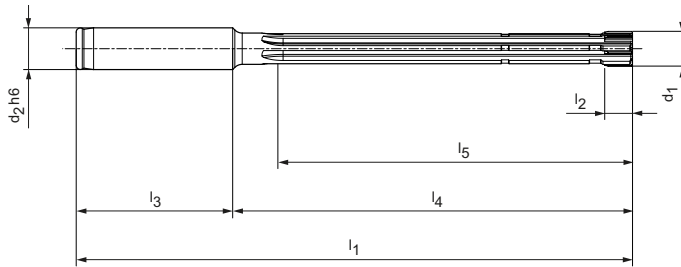

Preferred series in H7

d ₁ H7	Dimensions						z	Order no.
	d ₂ h6	l ₁	l ₂	l ₃	l ₄	l ₅		
10,000	12	160	8	45	115	100	6	31449061
12,000	12	160	8	45	115	100	6	31449062
14,000	12	160	8	45	115	100	6	31449063
16,000	16	180	12	50	130	114	6	31449064
18,000	16	180	12	50	130	115	6	31449065
20,000	20	200	12	60	140	120	6	31449066
22,000	20	200	12	60	140	120	6	31449067
24,000	20	200	12	60	140	120	6	31449068
25,000	20	200	12	60	140	120	6	31449069
28,000	25	210	12	60	150	130	6	31449071
30,000	25	210	12	60	150	130	6	31449072
32,000	25	210	12	60	150	130	6	31449073

Configurable features



Bore diameter tolerance ≥ IT6:
 - Diameter in increments of 0.001 mm freely selectable
 - Can be ordered in tolerance ≥ IT6

Specification:
 B042701Ø[Diameter][Tolerance]

G variant (see page 303):
 - Diameter in increments of 0.001 mm freely selectable
 - Can be ordered from tolerances ≥ 3 µm (G variant, see cutting data)

G variant specification:
 B042701Ø[Diameter][Tolerance]

Dimensions of configurable series IT6

d ₁	d ₂	l ₁	l ₂	l ₃	l ₄	l ₅	z
9,900 - 15,899	12	160	8	45	115	100	6
15,900 - 18,899	16	180	12	50	130	113	6
18,900 - 25,899	20	200	12	60	140	120	6
25,900 - 32,200	25	210	12	60	150	130	6

IT6 tolerance example:
 B042701Ø16.350H6

Bore diameter d₁ = 16.350 H6

G variant example:
 B042701Ø16.350-3

Special tool diameter d₁ = 16.350 -3 µm

Dimensions in mm.

For cutting data recommendations, see end of chapter.

Drill-Reamer-Pyramid | B093505

Drill reamer with pyramid tip (5xD), internal coolant supply



Design:

- Drill diameter: 3.970 - 16.050 mm
- Bore tolerance: ≥ IT 7
- Cutting material: Solid carbide, special TiAlN coating (HP358)
- Number of cutting edges: 2
- Number of margin lands: 4
- Tip angle: 140°
- Helix angle: 30°
- Special features: With pyramid tip, inclined bore entrance up to max. 10°

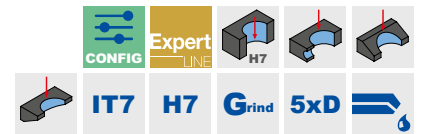
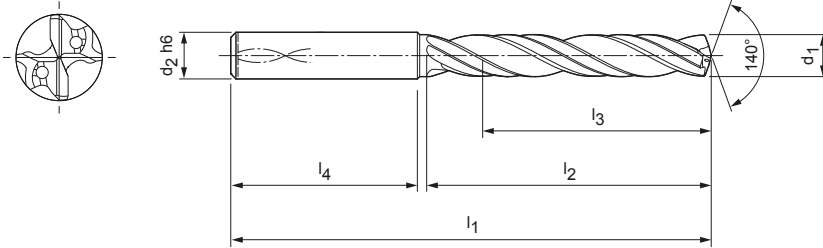

Preferred series available from stock in H7 | ±0.003

Dimensions							Shank form HA
d ₁	Tolerance	d ₂ h6	l ₁	l ₂	l ₃	l ₄	Order no.
4,000	H7	6	74	36	29	36	31178666
5,000	H7	6	91	53	43	36	31178667
5,980	±0,003	6	91	53	43	36	31178565
6,000	±0,003	6	91	53	43	36	31178567
6,000	H7	6	91	53	43	36	31178668
6,010	±0,003	6	91	53	43	36	31178568
6,020	±0,003	6	91	53	43	36	31178569
7,000	H7	8	91	53	43	36	31178669
7,980	±0,003	8	91	53	43	36	31178637
8,000	±0,003	8	91	53	43	36	31178639
8,000	H7	8	91	53	43	36	31178670
8,010	±0,003	8	91	53	43	36	31178640
8,020	±0,003	8	91	53	43	36	31178641
9,000	H7	10	103	61	49	40	31178671
9,540	±0,003	10	103	61	49	40	31178647
10,000	±0,003	10	103	61	49	40	31178651
10,000	H7	10	103	61	49	40	31178672
10,010	±0,003	10	103	61	49	40	31178652
10,020	±0,003	10	103	61	49	40	31178653
11,980	±0,003	12	118	71	56	45	31178655
11,990	±0,003	12	118	71	56	45	31178656
12,000	±0,003	12	118	71	56	45	31178657
12,000	H7	12	118	71	56	45	31178673
12,010	±0,003	12	118	71	56	45	31178658
12,020	±0,003	12	118	71	56	45	31178659
12,700	±0,003	14	124	77	60	45	31178663
14,000	H7	14	124	77	60	45	31178674
16,000	H7	16	133	83	63	48	31178675

Configurable features



Bore diameter tolerance \geq IT7:
 - Diameter in increments of 0.001 mm freely selectable
 - Can be ordered in tolerance \geq IT7



Specification:
 B093505-[Diameter][Tolerance]AR

G variant (see page 303):
 - Diameter in increments of 0.001 mm freely selectable
 - Can be ordered from tolerances $\geq 6 \mu\text{m}$

G variant specification:
 B093505-[Diameter][Tolerance]AR

Dimensions of configurable series IT7 and G variants

d_1	d_2 h6	l_1	l_2	l_3	l_4
3,970 - 4,800	6	74	36	29	36
4,801 - 6,050	6	91	53	43	36
6,051 - 8,050	8	91	53	43	36
8,051 - 10,050	10	103	61	49	40
10,051 - 12,050	12	118	71	56	45
12,051 - 14,050	14	124	77	60	45
14,051 - 16,050	16	133	83	63	48

IT7 tolerance example:
 B093505-11.530H7AR

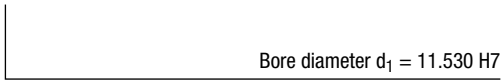

G variant example:
 B093505-11.530+3-3AR

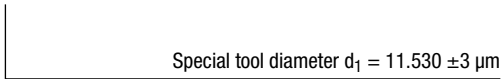

Dimensions in mm.
 For cutting data recommendations, see end of chapter.
 Special designs and other coatings available upon request.

Drill-Reamer | B093305

Drill reamer (5xD), internal coolant supply

Design:

Drill diameter:	3.970 - 16.050 mm
Bore tolerance:	≥ IT 7
Cutting material:	Solid carbide, special TiAlN coating (HP835)
Number of cutting edges:	2
Number of margin lands:	4
Point geometry:	Specific geometry
Tip angle:	140°
Helix angle:	30°

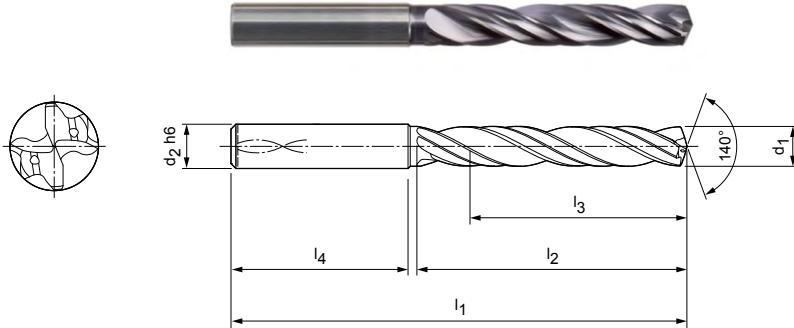

Preferred series available from stock in H7 | ±0.003

Dimensions							Shank form HA
d ₁	Tolerance	d ₂ h6	l ₁	l ₂	l ₃	l ₄	Order no.
4,000	H7	6	74	36	29	36	30134903
5,000	H7	6	91	53	43	36	30157641
6,000	±0,003	6	91	53	43	36	30120152
6,000	H7	6	91	53	43	36	30060348
6,010	±0,003	6	91	53	43	36	30120153
6,020	±0,003	6	91	53	43	36	30120154
7,000	H7	8	91	53	43	36	30076515
8,000	±0,003	8	91	53	43	36	30099663
8,000	H7	8	91	53	43	36	30072738
8,010	±0,003	8	91	53	43	36	30120194
8,020	±0,003	8	91	53	43	36	30120195
9,000	H7	10	103	61	49	40	30076516
10,000	H7	10	103	61	49	40	30072099
10,010	±0,003	10	103	61	49	40	30120233
10,020	±0,003	10	103	61	49	40	30120234
12,000	±0,003	12	118	71	56	45	30120272
12,000	H7	12	118	71	56	45	30060349
12,010	±0,003	12	118	71	56	45	30120273
12,020	±0,003	12	118	71	56	45	30120274
14,000	H7	14	124	77	60	45	30060350
16,000	H7	16	133	83	63	48	30060351

Configurable features



Bore diameter tolerance ≥ IT7:

- Diameter in increments of 0.001 mm freely selectable
- Can be ordered in tolerance ≥ IT7



Specification:
B093305-[Diameter][Tolerance]AE

G variant (see page 303):

- Diameter in increments of 0.001 mm freely selectable
- Can be ordered from tolerances ≥ 6 μm

G variant specification:
B093305-[Diameter][Tolerance]AE

Dimensions of configurable series IT7 and G variants

d ₁	d ₂ h6	l ₁	l ₂	l ₃	l ₄
3,970 - 4,800	6	74	36	29	36
4,801 - 6,050	6	91	53	43	36
6,051 - 8,050	8	91	53	43	36
8,051 - 10,050	10	103	61	49	40
10,051 - 12,050	12	118	71	56	45
12,051 - 14,050	14	124	77	60	45
14,051 - 16,050	16	133	83	63	48

IT7 tolerance example:
B093305-11.530H7AE

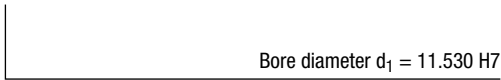

G variant example:
B093305-11.530+3-3AE

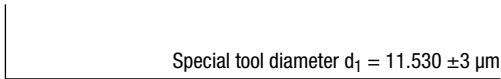

Dimensions in mm.

For cutting data recommendations, see end of chapter.

Special designs and other coatings available upon request.

Drill-Reamer | B093303

Drill reamer (3xD), internal coolant supply

Design:

Drill diameter: 3.970 - 16.050 mm
 Bore tolerance: ≥ IT 7
 Cutting material: Solid carbide, special TiAlN coating (HP835)
 Number of cutting edges: 2
 Number of margin lands: 4
 Point geometry: Specific geometry
 Tip angle: 140°
 Helix angle: 30°

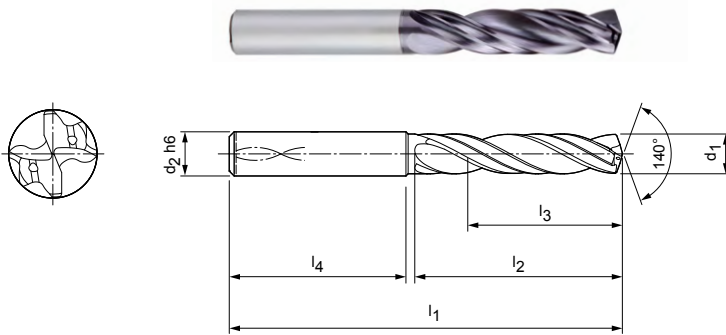

Preferred series available from stock in H7 | ±0.003

Dimensions							Shank form HA
d ₁	Tolerance	d ₂ h6	l ₁	l ₂	l ₃	l ₄	Order no.
4,000	H7	6	66	24	17	36	30115438
5,000	H7	6	79	34	24	36	30095401
6,000	±0,003	6	79	34	24	36	30119701
6,000	H7	6	79	34	24	36	30072761
6,010	±0,003	6	79	34	24	36	30119702
6,020	±0,003	6	79	34	24	36	30119703
7,000	H7	8	79	34	24	36	30076509
7,980	±0,003	8	79	34	24	36	30119739
8,000	±0,003	8	79	34	24	36	30095195
8,000	H7	8	79	34	24	36	30072737
8,010	±0,003	8	79	34	24	36	30119740
8,020	±0,003	8	79	34	24	36	30119741
9,000	H7	10	89	47	35	40	30076510
9,990	±0,003	10	89	47	35	40	30119780
10,000	±0,003	10	89	47	35	40	30119781
10,000	H7	10	89	47	35	40	30072858
10,010	±0,003	10	89	47	35	40	30119782
10,020	±0,003	10	89	47	35	40	30119783
12,000	±0,003	12	102	55	40	45	30119832
12,000	H7	12	102	55	40	45	30072857
14,000	H7	14	107	60	43	45	30060346
16,000	H7	16	115	65	45	48	30060347

Configurable features



Bore diameter tolerance ≥ IT7:

- Diameter in increments of 0.001 mm freely selectable
- Can be ordered in tolerance ≥ IT7



Specification:

B093303-[Diameter][Tolerance]AE

G variant (see page 303):

- Diameter in increments of 0.001 mm freely selectable
- Can be ordered from tolerances ≥ 6 μm

G variant specification:

B093303-[Diameter][Tolerance]AE

Dimensions of configurable series IT7 and G variants

d ₁	d ₂ h6	l ₁	l ₂	l ₃	l ₄
3,970 - 4,800	6	66	24	17	36
4,801 - 6,050	6	79	34	24	36
6,051 - 8,050	8	79	34	24	36
8,051 - 10,050	10	89	47	35	40
10,051 - 12,050	12	102	55	40	45
12,051 - 14,050	14	107	60	43	45
14,051 - 16,050	16	115	65	45	48

IT7 tolerance example:

B093303-11.530H7AE

Bore diameter d₁ = 11.530 H7

G variant example:

B093303-11.530+3-3AE

Special tool diameter d₁ = 11.530 ±3 μm

Dimensions in mm.

For cutting data recommendations, see end of chapter.

Special designs and other coatings available upon request.

Drill-Reamer | B093301

Drill reamer (3xD), external coolant supply

Design:

Drill diameter:	3.970 - 16.050 mm
Bore tolerance:	≥ IT 7
Cutting material:	Solid carbide, special TiAlN coating (HP835)
Number of cutting edges:	2
Number of margin lands:	4
Point geometry:	Specific geometry
Tip angle:	140°
Helix angle:	30°

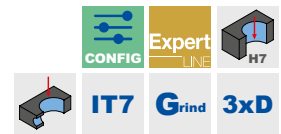
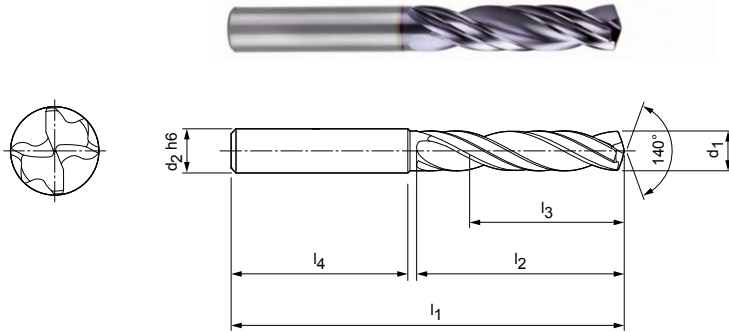

Preferred series available from stock in ±0.003

Dimensions							Shank form HA
d ₁	Tolerance	d ₂ h6	l ₁	l ₂	l ₃	l ₄	Order no.
5,990	±0,003	6	79	34	24	36	30184711
6,000	±0,003	6	79	34	24	36	30099666
6,020	±0,003	6	79	34	24	36	30219852
8,000	±0,003	8	79	34	24	36	30175468
10,000	±0,003	10	89	47	35	40	30099665

Configurable features



G variants:

- Diameter in increments of 0.001 mm freely selectable
- Can be ordered from tolerances ≥ 6 μm

G variant specification:

B093301-[Diameter][Tolerance]AE

G variant example:

B093301-11.530+3-3AE

Special tool diameter d₁ = 11.530 ±3 μm

Dimensions of configurable series G variant

d ₁	d ₂ h6	l ₁	l ₂	l ₃	l ₄
3,970 - 4,800	6	66	24	17	36
4,801 - 6,050	6	79	34	24	36
6,051 - 8,050	8	79	34	24	36
8,051 - 10,050	10	89	47	35	40
10,051 - 12,050	12	102	55	40	45
12,051 - 14,050	14	107	60	43	45
14,051 - 16,050	16	115	65	45	48

Dimensions in mm.

For cutting data recommendations, see end of chapter.

Special designs and other coatings available upon request.

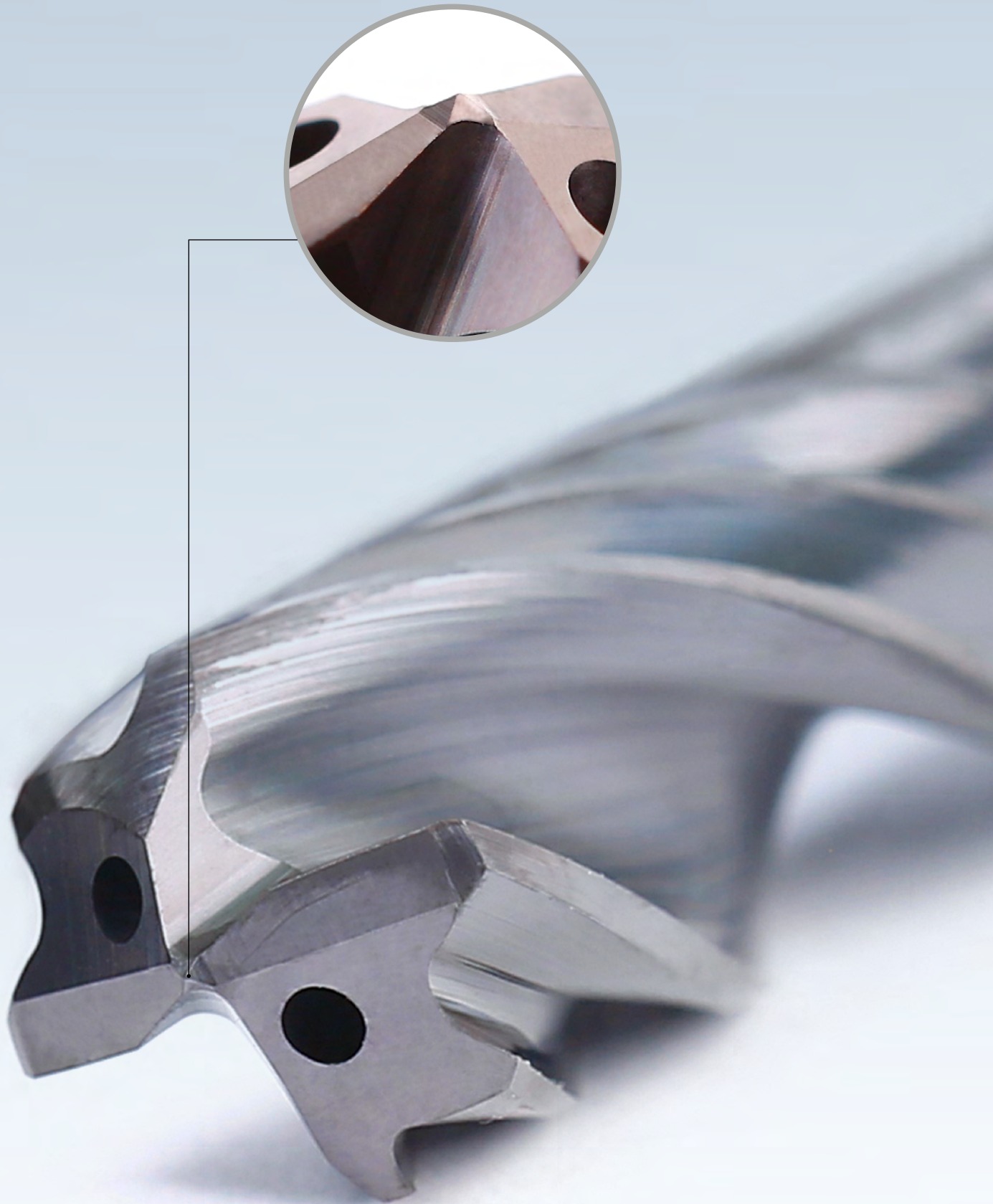

XR 06 | B081631

Replaceable head reamer for through bore, internal coolant supply

Design:

Diameter:

8.000 - 40.200 mm

Cutting direction:

Right-hand cutting

Cutting material:

Solid carbide,
BSP-coated (HP145)

Groove direction:

Left-hand fluted

Geometry:

HPC geometry

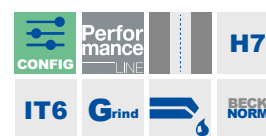
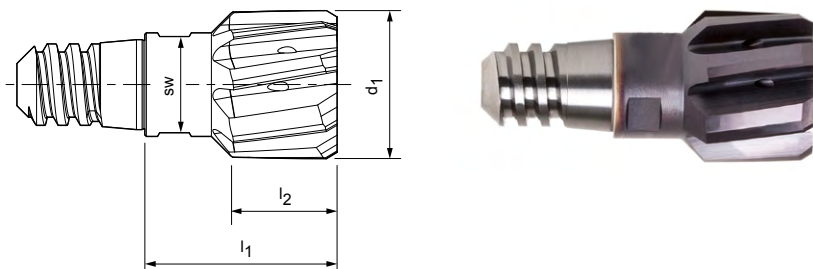

Preferred series in H7

Dimensions				z	AF	Order no.
d ₁ H7	XS	l ₁	l ₂			
8,000	6	18	10	6	6	30461204
8,500	6	18	10	6	6	30461206
9,000	6	18	10	6	6	30461208
9,500	6	18	10	6	6	30461211
10,000	6	18	10	6	6	30461213
10,500	6	18	10	6	6	30461225
11,000	8	20	10	6	8	30461226
11,500	8	20	10	6	8	30461227
12,000	8	20	10	6	8	30461229
12,500	8	20	10	6	8	30461231
13,000	10	22	10	6	10	30461232
14,000	10	22	12	6	10	30461237
15,000	10	22	12	6	10	30461239
16,000	10	22	12	6	10	30461243
17,000	10	22	12	8	10	30461244
18,000	12	26	14	8	13	30461245
19,000	12	26	14	8	13	30461248
20,000	12	26	14	8	13	30461249
21,000	12	26	14	8	13	30552610
22,000	16	26	14	8	16	30552611
23,000	16	26	14	8	16	30552612
24,000	16	26	14	8	16	30552613
25,000	16	26	14	8	16	30552614
26,000	16	26	14	8	16	30552615
27,000	16	26	14	8	16	30552616
28,000	16*	26	14	8	24	30552617
29,000	16*	26	14	8	24	30552618
30,000	16*	26	14	8	24	30552619
31,000	16*	30	14	8	24	30552620
32,000	16*	30	14	8	24	30552621
33,000	16*	30	14	8	24	30552622
34,000	16*	30	14	8	24	30552623
35,000	16*	30	14	8	24	30552624
36,000	16*	30	14	8	24	30552625
37,000	16*	30	14	8	24	30552626
38,000	16*	30	14	8	24	30552627
39,000	16*	30	14	8	24	30552628
40,000	16*	30	14	8	24	30540962

Configurable features

**Bore diameter tolerance \geq IT6:**

- Diameter in increments of 0.001 mm freely selectable
- Can be ordered in tolerance \geq IT6

**Specification:**

B081631[Diameter][Tolerance]

G variant (see page 303):

- Diameter in increments of 0.001 mm freely selectable
- Can be ordered from tolerances $\geq 4 \mu\text{m}$

G variant specification:

B081631[Diameter][Tolerance]

IT6 tolerance example:B081631-~~00~~16.350H6Bore diameter $d_1 = 16.350 \text{ H6}$ **G variant example:**B081631-~~0~~16.350-4Special tool diameter $d_1 = 16.350 -4 \mu\text{m}$

Dimensions of configurable series IT6

d_1	XS	l_1	l_2	z	SW
8,000-10,700	6	18	10	6	6
10,701-12,700	8	20	10	6	8
12,701-13,200	10	22	10	6	10
13,201-16,200	10	22	12	6	10
16,201-17,200	10	22	12	8	10
17,201-21,200	12	26	14	8	13
21,201-27,200	16	26	14	8	16
27,201-30,200	16*	26	14	8	24
30,201-40,200	16*	30	14	8	24

* Associated XR replaceable head holders with enlarged face connection for XS 16 from $\emptyset 27.201 \text{ mm}$, see page 118

XR 06 | B081632

Replaceable head reamer for through bore, internal coolant supply

Design:

Diameter:

8.000 - 40.200 mm

Cutting direction:

Right-hand cutting

Cutting material:

Solid carbide,
BVA-coated (HP145)

Groove direction:

Left-hand fluted

Geometry:

HPC geometry

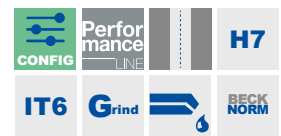
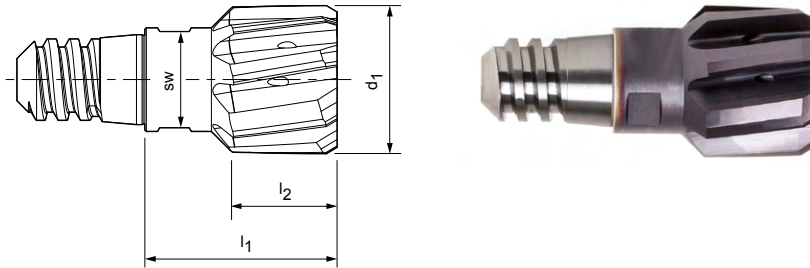
Preferred series in H7

Dimensions				z	AF	Order no.
d ₁ H7	XS	l ₁	l ₂			
8,000	6	18	10	6	6	30967156
8,500	6	18	10	6	6	30967157
9,000	6	18	10	6	6	30967158
9,500	6	18	10	6	6	30967159
10,000	6	18	10	6	6	30967170
10,500	6	18	10	6	6	30967171
11,000	8	20	10	6	8	30967172
11,500	8	20	10	6	8	30967173
12,000	8	20	10	6	8	30967174
12,500	8	20	10	6	8	30967175
13,000	10	22	10	6	10	30967176
14,000	10	22	12	6	10	30967177
15,000	10	22	12	6	10	30967178
16,000	10	22	12	6	10	30967179
17,000	10	22	12	8	10	30967180
18,000	12	26	14	8	13	30967181
19,000	12	26	14	8	13	30967182
20,000	12	26	14	8	13	30967183
21,000	12	26	14	8	13	30967184
22,000	16	26	14	8	16	30967185
23,000	16	26	14	8	16	30967186
24,000	16	26	14	8	16	30967187
25,000	16	26	14	8	16	30967188
26,000	16	26	14	8	16	30967189
27,000	16	26	14	8	16	30967190
28,000	16*	26	14	8	24	30967191
29,000	16*	26	14	8	24	30967192
30,000	16*	26	14	8	24	30967193
31,000	16*	30	14	8	24	30967194
32,000	16*	30	14	8	24	30967195
33,000	16*	30	14	8	24	30967196
34,000	16*	30	14	8	24	30967197
35,000	16*	30	14	8	24	30967198
36,000	16*	30	14	8	24	30967199
37,000	16*	30	14	8	24	30967200
38,000	16*	30	14	8	24	30967201
39,000	16*	30	14	8	24	30967202
40,000	16*	30	14	8	24	30967203

Configurable features

**Bore diameter tolerance \geq IT6:**

- Diameter in increments of 0.001 mm freely selectable
- Can be ordered in tolerance \geq IT6

**Specification:**

B081632[Diameter][Tolerance]

G variant (see page 303):

- Diameter in increments of 0.001 mm freely selectable
- Can be ordered from tolerances $\geq 4 \mu\text{m}$

G variant specification:

B081632[Diameter][Tolerance]

IT6 tolerance example:B081632-~~00~~16.350H6Bore diameter $d_1 = 16.350 \text{ H6}$ **G variant example:**B081632-~~0~~16.350-4Special tool diameter $d_1 = 16.350 -4 \mu\text{m}$

Dimensions of configurable series IT6

d_1	XS	l_1	l_2	z	SW
8,000-10,700	6	18	10	6	6
10,701-12,700	8	20	10	6	8
12,701-13,200	10	22	10	6	10
13,201-16,200	10	22	12	6	10
16,201-17,200	10	22	12	8	10
17,201-21,200	12	26	14	8	13
21,201-27,200	16	26	14	8	16
27,201-30,200	16*	26	14	8	24
30,201-40,200	16*	30	14	8	24

* Associated XR replaceable head holders with enlarged face connection for XS 16 from $\emptyset 27.201 \text{ mm}$, see page 118

XR 06 | B081633

Replaceable head reamer for through bore, internal coolant supply

Design:

Diameter:

8.000 - 40.200 mm

Cutting direction:

Right-hand cutting

Cutting material:

Solid carbide,
BTI-coated (HP625)

Groove direction:

Left-hand fluted

Geometry:

HPC geometry

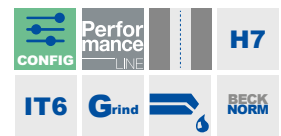
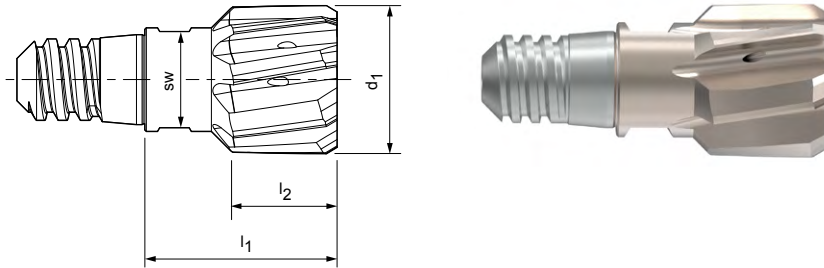

Preferred series in H7

Dimensions				z	AF	Order no.
d ₁ H7	XS	l ₁	l ₂			
8,000	6	18	10	6	6	30967243
8,500	6	18	10	6	6	30967244
9,000	6	18	10	6	6	30967245
9,500	6	18	10	6	6	30967246
10,000	6	18	10	6	6	30967247
10,500	6	18	10	6	6	30967248
11,000	8	20	10	6	8	30967249
11,500	8	20	10	6	8	30967250
12,000	8	20	10	6	8	30967251
12,500	8	20	10	6	8	30967252
13,000	10	22	10	6	10	30967253
14,000	10	22	12	6	10	30967254
15,000	10	22	12	6	10	30967255
16,000	10	22	12	6	10	30967256
17,000	10	22	12	8	10	30967257
18,000	12	26	14	8	13	30967258
19,000	12	26	14	8	13	30967259
20,000	12	26	14	8	13	30967260
21,000	12	26	14	8	13	30967261
22,000	16	26	14	8	16	30967262
23,000	16	26	14	8	16	30967263
24,000	16	26	14	8	16	30967264
25,000	16	26	14	8	16	30967265
26,000	16	26	14	8	16	30967266
27,000	16	26	14	8	16	30967267
28,000	16*	26	14	8	24	30967268
29,000	16*	26	14	8	24	30967269
30,000	16*	26	14	8	24	30967270
31,000	16*	30	14	8	24	30967271
32,000	16*	30	14	8	24	30967272
33,000	16*	30	14	8	24	30967273
34,000	16*	30	14	8	24	30967274
35,000	16*	30	14	8	24	30967275
36,000	16*	30	14	8	24	30967276
37,000	16*	30	14	8	24	30967277
38,000	16*	30	14	8	24	30967278
39,000	16*	30	14	8	24	30967279
40,000	16*	30	14	8	24	30967280

Configurable features

**Bore diameter tolerance \geq IT6:**

- Diameter in increments of 0.001 mm freely selectable
- Can be ordered in tolerance \geq IT6

**Specification:**

B081633[Diameter][Tolerance]

G variant (see page 303):

- Diameter in increments of 0.001 mm freely selectable
- Can be ordered from tolerances $\geq 4 \mu\text{m}$

G variant specification:

B081633[Diameter][Tolerance]

IT6 tolerance example:B081633-~~00~~16.350H6Bore diameter $d_1 = 16.350 \text{ H6}$ **G variant example:**B081633-~~016~~.350-4Special tool diameter $d_1 = 16.350 -4 \mu\text{m}$

Dimensions of configurable series IT6

d_1	XS	l_1	l_2	z	SW
8,000-10,700	6	18	10	6	6
10,701-12,700	8	20	10	6	8
12,701-13,200	10	22	10	6	10
13,201-16,200	10	22	12	6	10
16,201-17,200	10	22	12	8	10
17,201-21,200	12	26	14	8	13
21,201-27,200	16	26	14	8	16
27,201-30,200	16*	26	14	8	24
30,201-40,200	16*	30	14	8	24

* Associated XR replaceable head holders with enlarged face connection for XS 16 from $\emptyset 27.201 \text{ mm}$, see page 118

XR 06 | B081634

Replaceable head reamer for through bore, internal coolant supply

Design:

Diameter:

8.000 - 40.200 mm

Cutting direction:

Right-hand cutting

Cutting material:

Solid carbide,
BAL-coated (HP622)

Groove direction:

Straight fluted

Geometry:

HPC geometry

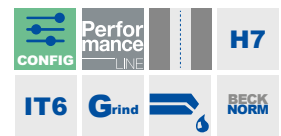
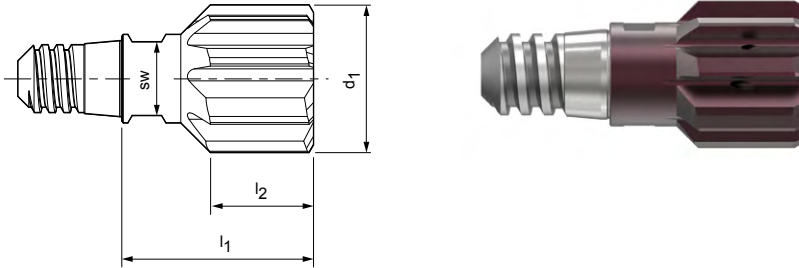
Preferred series in H7

Dimensions				z	AF	Order no.
d ₁ H7	XS	l ₁	l ₂			
8,000	6	18	10	6	6	30967281
8,500	6	18	10	6	6	30967282
9,000	6	18	10	6	6	30967283
9,500	6	18	10	6	6	30967284
10,000	6	18	10	6	6	30967285
10,500	6	18	10	6	6	30967286
11,000	8	20	10	6	8	30967287
11,500	8	20	10	6	8	30967288
12,000	8	20	10	6	8	30967289
12,500	8	20	10	6	8	30967290
13,000	10	22	10	6	10	30967291
14,000	10	22	12	6	10	30967292
15,000	10	22	12	6	10	30967293
16,000	10	22	12	6	10	30967294
17,000	10	22	12	8	10	30967295
18,000	12	26	14	8	13	30967296
19,000	12	26	14	8	13	30967297
20,000	12	26	14	8	13	30967298
21,000	12	26	14	8	13	30967299
22,000	16	26	14	8	16	30967300
23,000	16	26	14	8	16	30967301
24,000	16	26	14	8	16	30967302
25,000	16	26	14	8	16	30967303
26,000	16	26	14	8	16	30967304
27,000	16	26	14	8	16	30967305
28,000	16*	26	14	8	24	30967306
29,000	16*	26	14	8	24	30967307
30,000	16*	26	14	8	24	30967308
31,000	16*	30	14	8	24	30967309
32,000	16*	30	14	8	24	30967310
33,000	16*	30	14	8	24	30967311
34,000	16*	30	14	8	24	30967312
35,000	16*	30	14	8	24	30967313
36,000	16*	30	14	8	24	30967314
37,000	16*	30	14	8	24	30967315
38,000	16*	30	14	8	24	30967316
39,000	16*	30	14	8	24	30967317
40,000	16*	30	14	8	24	30967318

Configurable features

**Bore diameter tolerance \geq IT6:**

- Diameter in increments of 0.001 mm freely selectable
- Can be ordered in tolerance \geq IT6

**Specification:**B081634[**Diameter**][**Tolerance**]**G variant** (see page 303):

- Diameter in increments of 0.001 mm freely selectable
- Can be ordered from tolerances $\geq 4 \mu\text{m}$

G variant specification:B081634[**Diameter**][**Tolerance**]**IT6 tolerance example:**B081634-~~00~~**16.350H6**Bore diameter $d_1 = 16.350 \text{ H6}$ **G variant example:**B081634-~~016.350~~-**4**Special tool diameter $d_1 = 16.350 -4 \mu\text{m}$

Dimensions of configurable series IT6

d_1	XS	l_1	l_2	z	SW
8,000-10,700	6	18	10	6	6
10,701-12,700	8	20	10	6	8
12,701-13,200	10	22	10	6	10
13,201-16,200	10	22	12	6	10
16,201-17,200	10	22	12	8	10
17,201-21,200	12	26	14	8	13
21,201-27,200	16	26	14	8	16
27,201-30,200	16*	26	14	8	24
30,201-40,200	16*	30	14	8	24

* Associated XR replaceable head holders with enlarged face connection for XS 16 from $\emptyset 27.201 \text{ mm}$, see page 118

XR 06 | B081639

Replaceable head reamer for through bore, internal coolant supply

Design:

Diameter: 8.000 - 40.200 mm
 Cutting direction: Right-hand cutting
 Cutting material: Solid carbide, CVD-coated (HC419)
 Groove direction: Straight fluted
 Geometry: HPC geometry

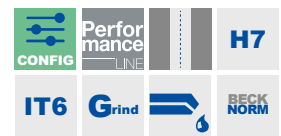
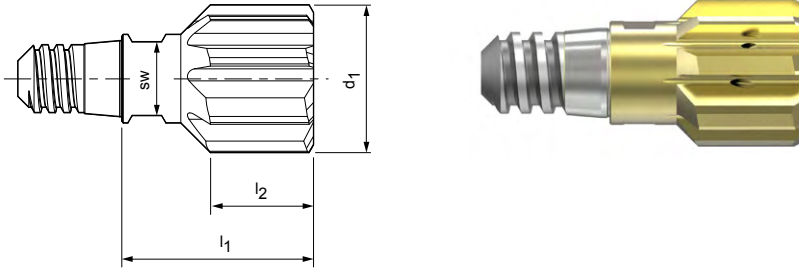

Preferred series in H7

Dimensions				z	AF	Order no.
d ₁ H7	XS	l ₁	l ₂			
8,000	6	18	10	6	6	30967528
8,500	6	18	10	6	6	30967529
9,000	6	18	10	6	6	30967530
9,500	6	18	10	6	6	30967531
10,000	6	18	10	6	6	30967532
10,500	6	18	10	6	6	30967533
11,000	8	20	10	6	8	30967534
11,500	8	20	10	6	8	30967535
12,000	8	20	10	6	8	30967536
12,500	8	20	10	6	8	30967537
13,000	10	22	10	6	10	30967538
14,000	10	22	12	6	10	30967539
15,000	10	22	12	6	10	30967540
16,000	10	22	12	6	10	30967541
17,000	10	22	12	8	10	30967542
18,000	12	26	14	8	13	30967543
19,000	12	26	14	8	13	30967544
20,000	12	26	14	8	13	30967545
21,000	12	26	14	8	13	30967546
22,000	16	26	14	8	16	30967547
23,000	16	26	14	8	16	30967548
24,000	16	26	14	8	16	30967549
25,000	16	26	14	8	16	30967550
26,000	16	26	14	8	16	30967551
27,000	16	26	14	8	16	30967552
28,000	16*	26	14	8	24	30967553
29,000	16*	26	14	8	24	30967554
30,000	16*	26	14	8	24	30967555
31,000	16*	30	14	8	24	30967556
32,000	16*	30	14	8	24	30967557
33,000	16*	30	14	8	24	30967558
34,000	16*	30	14	8	24	30967559
35,000	16*	30	14	8	24	30967560
36,000	16*	30	14	8	24	30967561
37,000	16*	30	14	8	24	30967562
38,000	16*	30	14	8	24	30967563
39,000	16*	30	14	8	24	30967564
40,000	16*	30	14	8	24	30967565

Configurable features

**Bore diameter tolerance \geq IT6:**

- Diameter in increments of 0.001 mm freely selectable
- Can be ordered in tolerance \geq IT6

**Specification:**B081639[**Diameter**][**Tolerance**]**G variant** (see page 303):

- Diameter in increments of 0.001 mm freely selectable
- Can be ordered from tolerances $\geq 4 \mu\text{m}$

G variant specification:B081639[**Diameter**][**Tolerance**]**IT6 tolerance example:**B081639-~~00~~**16.350H6**Bore diameter $d_1 = 16.350 \text{ H6}$ **G variant example:**B081639-~~016.350~~-**4**Special tool diameter $d_1 = 16.350 -4 \mu\text{m}$

Dimensions of configurable series IT6

d_1	XS	l_1	l_2	z	SW
8,000-10,700	6	18	10	6	6
10,701-12,700	8	20	10	6	8
12,701-13,200	10	22	10	6	10
13,201-16,200	10	22	12	6	10
16,201-17,200	10	22	12	8	10
17,201-21,200	12	26	14	8	13
21,201-27,200	16	26	14	8	16
27,201-30,200	16*	26	14	8	24
30,201-40,200	16*	30	14	8	24

* Associated XR replaceable head holders with enlarged face connection for XS 16 from $\emptyset 27.201 \text{ mm}$, see page 118

XR 01 | B081610

Replaceable head reamer for through bore with brazed blades, internal coolant supply

Design:

Diameter:

8.000 - 40.200 mm

Cutting direction:

Right-hand cutting

Cutting material:

 Carbide, uncoated
(HU612)

Groove direction:

Left-hand fluted

Lead angle:

30°

Rake angle:

6°

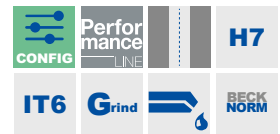
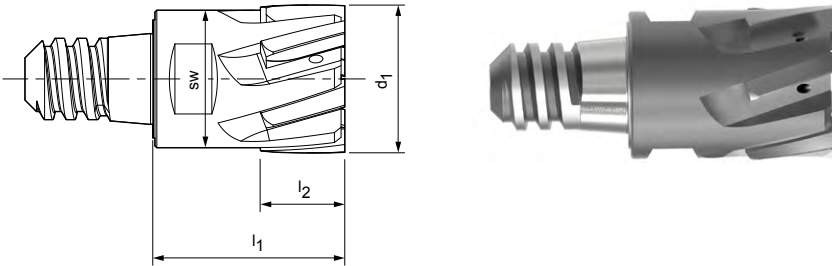
Preferred series in H7

Dimensions				z	AF	Order no.
d ₁ H7	XS	l ₁	l ₂			
8,000	6	18	8	4	6	30516058
10,000	6	18	8	6	8	30516059
12,000	8	20	8	6	8	30516060
14,000	10	22	8	6	10	30516061
16,000	10	22	8	6	10	30516062
18,000	12	26	12	6	13	30516063
20,000	12	26	12	6	16	30516064
22,000	16	26	12	6	16	30516065
24,000	16	26	12	6	16	30516066
25,000	16	26	12	6	19	30516067
26,000	16	26	12	6	19	30516068
28,000	16	26	12	6	21	30516069
30,000	16	26	12	8	24	30516070
32,000	24	30	12	8	24	30516071
34,000	24	30	12	8	27	30516072
36,000	24	30	12	8	30	30516073
38,000	24	30	12	8	30	30516074
40,000	24	30	12	8	30	30516075

Configurable features

**Bore diameter tolerance \geq IT6:**

- Diameter in increments of 0.001 mm freely selectable
- Can be ordered in tolerance \geq IT6

**Specification:**

B081610[Diameter][Tolerance]

G variant (see page 303):

- Diameter in increments of 0.001 mm freely selectable
- Can be ordered from tolerances $\geq 5 \mu\text{m}$

G variant specification:

B081610[Diameter][Tolerance]

IT6 tolerance example:B081610-~~00~~16.350H6Bore diameter $d_1 = 16.350 \text{ H6}$ **G variant example:**B081610-~~016~~.350-5Special tool diameter $d_1 = 16.350 -5 \mu\text{m}$

Dimensions of configurable series IT6

d_1	XS	l_1	l_2	z	SW
8,000-9,700	6	18	8	4	6
9,701-10,700	6	18	8	6	8
10,701-12,700	8	20	8	6	8
12,701-16,200	10	22	8	6	10
16,201-17,200	10	22	8	6	13
17,201-19,200	12	26	12	6	13
19,201-21,200	12	26	12	6	16
21,201-24,200	16	26	12	6	16
24,201-26,200	16	26	12	6	19
26,201-28,200	16	26	12	6	21
28,201-29,200	16	26	12	6	24
29,201-30,200	16	26	12	8	24
30,201-32,200	24	30	12	8	24
32,201-34,200	24	30	12	8	27
34,201-40,200	24	30	12	8	30

Dimensions in mm.

For cutting data recommendations, see end of chapter.

Associated XR replaceable head holders, see page 118.

XR 01 | B081618

Replaceable head reamer for through bore with brazed blades, internal coolant supply

Design:

Diameter:

8.000 - 40.200 mm

Cutting direction:

Right-hand cutting

Cutting material:

 Carbide, BSP-coated
(HP421)

Groove direction:

Left-hand fluted

Lead angle:

30°

Rake angle:

6°

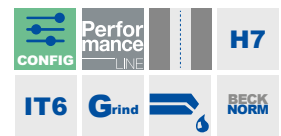
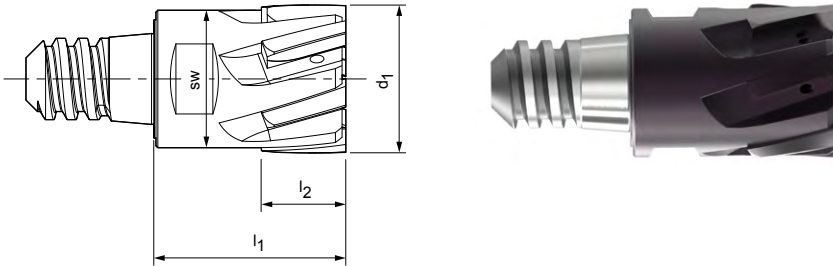
Preferred series in H7

Dimensions				z	AF	Order no.
d ₁ H7	XS	l ₁	l ₂			
8,000	6	18	8	4	6	30432555
10,000	6	18	8	6	8	30432556
12,000	8	20	8	6	8	30432557
14,000	10	22	8	6	10	30432558
16,000	10	22	8	6	10	30432559
18,000	12	26	12	6	13	30432560
20,000	12	26	12	6	16	30432561
22,000	16	26	12	6	16	30432562
24,000	16	26	12	6	16	30432563
25,000	16	26	12	6	19	30432564
26,000	16	26	12	6	19	30432565
28,000	16	26	12	6	21	30432566
30,000	16	26	12	8	24	30432567
32,000	24	30	12	8	24	30432667
34,000	24	30	12	8	27	30432669
36,000	24	30	12	8	30	30432670
38,000	24	30	12	8	30	30432671
40,000	24	30	12	8	30	30432672

Configurable features

**Bore diameter tolerance \geq IT6:**

- Diameter in increments of 0.001 mm freely selectable
- Can be ordered in tolerance \geq IT6

**Specification:**

B081618[Diameter][Tolerance]

G variant (see page 303):

- Diameter in increments of 0.001 mm freely selectable
- Can be ordered from tolerances $\geq 5 \mu\text{m}$

G variant specification:

B081618[Diameter][Tolerance]

IT6 tolerance example:B081618-~~00~~16.350H6Bore diameter $d_1 = 16.350 \text{ H6}$ **G variant example:**B081618-~~016~~.350-5Special tool diameter $d_1 = 16.350 -5 \mu\text{m}$

Dimensions of configurable series IT6

d_1	XS	l_1	l_2	z	SW
8,000-9,700	6	18	8	4	6
9,701-10,700	6	18	8	6	8
10,701-12,700	8	20	8	6	8
12,701-16,200	10	22	8	6	10
16,201-17,200	10	22	8	6	13
17,201-19,200	12	26	12	6	13
19,201-21,200	12	26	12	6	16
21,201-24,200	16	26	12	6	16
24,201-26,200	16	26	12	6	19
26,201-28,200	16	26	12	6	21
28,201-29,200	16	26	12	6	24
29,201-30,200	16	26	12	8	24
30,201-32,200	24	30	12	8	24
32,201-34,200	24	30	12	8	27
34,201-40,200	24	30	12	8	30

Dimensions in mm.

For cutting data recommendations, see end of chapter.

Associated XR replaceable head holders, see page 118.

XR 01 | B081611

Replaceable head reamer for through bore with brazed blades, internal coolant supply

Design:

Diameter: 8.000 - 40.200 mm
 Cutting direction: Right-hand cutting
 Cutting material: Carbide, BVA-coated (HP421)
 Groove direction: Left-hand fluted
 Lead angle: 30°
 Rake angle: 6°

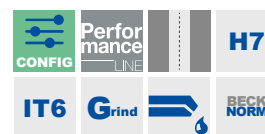
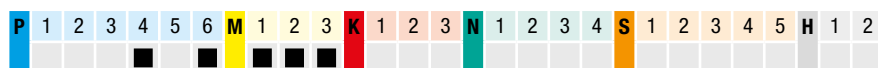
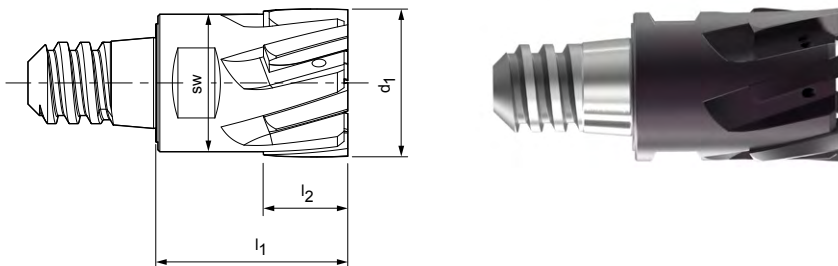

Preferred series in H7

Dimensions				z	AF	Order no.
d ₁ H7	XS	l ₁	l ₂			
8,000	6	18	8	4	6	30383184
10,000	6	18	8	6	8	30383185
12,000	8	20	8	6	8	30383186
14,000	10	22	8	6	10	30383187
16,000	10	22	8	6	10	30383188
18,000	12	26	12	6	13	30383189
20,000	12	26	12	6	16	30383190
22,000	16	26	12	6	16	30383191
24,000	16	26	12	6	16	30383192
25,000	16	26	12	6	19	30383193
26,000	16	26	12	6	19	30383194
28,000	16	26	12	6	21	30383195
30,000	16	26	12	8	24	30383196
32,000	24	30	12	8	24	30455216
34,000	24	30	12	8	27	30455217
36,000	24	30	12	8	30	30455218
38,000	24	30	12	8	30	30455219
40,000	24	30	12	8	30	30455220

Configurable features

**Bore diameter tolerance \geq IT6:**

- Diameter in increments of 0.001 mm freely selectable
- Can be ordered in tolerance \geq IT6

**Specification:**

B081611[Diameter][Tolerance]

G variant (see page 303):

- Diameter in increments of 0.001 mm freely selectable
- Can be ordered from tolerances $\geq 5 \mu\text{m}$

G variant specification:

B081611[Diameter][Tolerance]

IT6 tolerance example:B081611-~~00~~16.350H6Bore diameter $d_1 = 16.350 \text{ H6}$ **G variant example:**B081611-~~01~~6.350-5Special tool diameter $d_1 = 16.350 -5 \mu\text{m}$

Dimensions of configurable series IT6

d_1	XS	l_1	l_2	z	SW
8,000-9,700	6	18	8	4	6
9,701-10,700	6	18	8	6	8
10,701-12,700	8	20	8	6	8
12,701-16,200	10	22	8	6	10
16,201-17,200	10	22	8	6	13
17,201-19,200	12	26	12	6	13
19,201-21,200	12	26	12	6	16
21,201-24,200	16	26	12	6	16
24,201-26,200	16	26	12	6	19
26,201-28,200	16	26	12	6	21
28,201-29,200	16	26	12	6	24
29,201-30,200	16	26	12	8	24
30,201-32,200	24	30	12	8	24
32,201-34,200	24	30	12	8	27
34,201-40,200	24	30	12	8	30

Dimensions in mm.

For cutting data recommendations, see end of chapter.

Associated XR replaceable head holders, see page 118.

XR 01 | B081612

Replaceable head reamer for through bore with brazed blades, internal coolant supply

Design:

Diameter: 8.000 - 40.200 mm
 Cutting direction: Right-hand cutting
 Cutting material: Cermet, uncoated (CU130)
 Groove direction: Left-hand fluted
 Lead angle: 30°
 Rake angle: 6°

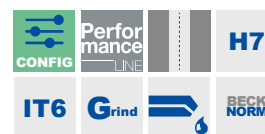
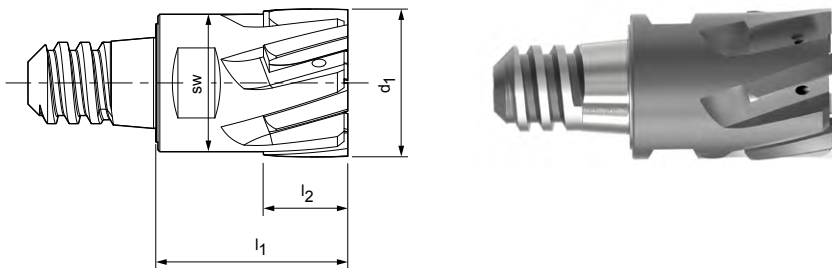

Preferred series in H7

Dimensions				z	AF	Order no.
d ₁ H7	XS	l ₁	l ₂			
8,000	6	18	8	4	6	30383155
10,000	6	18	8	6	8	30383172
12,000	8	20	8	6	8	30383173
14,000	10	22	8	6	10	30383174
16,000	10	22	8	6	10	30383175
18,000	12	26	12	6	13	30383176
20,000	12	26	12	6	16	30383177
22,000	16	26	12	6	16	30383178
24,000	16	26	12	6	16	30383179
25,000	16	26	12	6	19	30383180
26,000	16	26	12	6	19	30383181
28,000	16	26	12	6	21	30383182
30,000	16	26	12	8	24	30383183
32,000	24	30	12	8	24	30455211
34,000	24	30	12	8	27	30455212
36,000	24	30	12	8	30	30455213
38,000	24	30	12	8	30	30455214
40,000	24	30	12	8	30	30455215

Configurable features

**Bore diameter tolerance \geq IT6:**

- Diameter in increments of 0.001 mm freely selectable
- Can be ordered in tolerance \geq IT6

**Specification:**

B081612[Diameter][Tolerance]

G variant (see page 303):

- Diameter in increments of 0.001 mm freely selectable
- Can be ordered from tolerances $\geq 5 \mu\text{m}$

G variant specification:

B081612[Diameter][Tolerance]

IT6 tolerance example:B081612-~~Ø~~16.350H6Bore diameter $d_1 = 16.350 \text{ H6}$ **G variant example:**B081612-~~Ø~~16.350-5Special tool diameter $d_1 = 16.350 -5 \mu\text{m}$

Dimensions of configurable series IT6

d_1	XS	l_1	l_2	z	SW
8,000-9,700	6	18	8	4	6
9,701-10,700	6	18	8	6	8
10,701-12,700	8	20	8	6	8
12,701-16,200	10	22	8	6	10
16,201-17,200	10	22	8	6	13
17,201-19,200	12	26	12	6	13
19,201-21,200	12	26	12	6	16
21,201-24,200	16	26	12	6	16
24,201-26,200	16	26	12	6	19
26,201-28,200	16	26	12	6	21
28,201-29,200	16	26	12	6	24
29,201-30,200	16	26	12	8	24
30,201-32,200	24	30	12	8	24
32,201-34,200	24	30	12	8	27
34,201-40,200	24	30	12	8	30

Dimensions in mm.

For cutting data recommendations, see end of chapter.

Associated XR replaceable head holders, see page 118.

XR 01 | B081605

Replaceable head reamer for through bore with brazed blades, internal coolant supply

Design:

Diameter: 8.000 - 40.200 mm
 Cutting direction: Right-hand cutting
 Cutting material: PCD cutting blades (PU620)
 Groove direction: Straight fluted
 Lead angle: 45°
 Rake angle: 0°

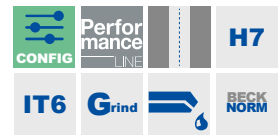
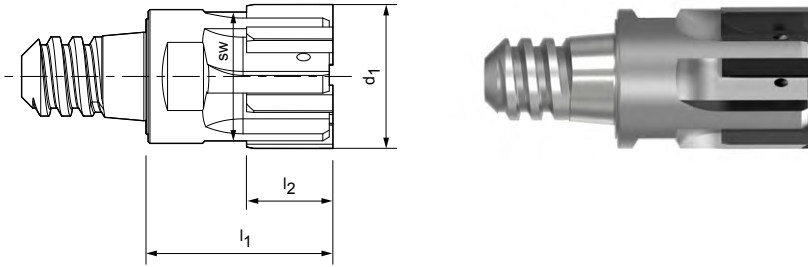

Preferred series in H7

Dimensions				z	AF	Order no.
d ₁ H7	XS	l ₁	l ₂			
8,000	6	18	8	4	6	30383223
10,000	6	18	8	6	8	30383224
12,000	8	20	8	6	8	30383225
14,000	10	22	8	6	10	30383226
16,000	10	22	8	6	10	30383227
18,000	12	26	12	6	13	30383228
20,000	12	26	12	6	16	30383229
22,000	16	26	12	6	16	30383230
24,000	16	26	12	6	16	30383231
25,000	16	26	12	6	19	30383232
26,000	16	26	12	6	19	30383233
28,000	16	26	12	6	21	30383234
30,000	16	26	12	8	24	30383235
32,000	24	30	12	8	24	30455232
34,000	24	30	12	8	27	30455233
36,000	24	30	12	8	30	30455235
38,000	24	30	12	8	30	30455236
40,000	24	30	12	8	30	30455237

Configurable features

**Bore diameter tolerance \geq IT6:**

- Diameter in increments of 0.001 mm freely selectable
- Can be ordered in tolerance \geq IT6

**Specification:**

B081605[Diameter][Tolerance]

G variant (see page 303):

- Diameter in increments of 0.001 mm freely selectable
- Can be ordered from tolerances $\geq 5 \mu\text{m}$

G variant specification:

B081605[Diameter][Tolerance]

IT6 tolerance example:B081605-~~00~~16.350H6Bore diameter $d_1 = 16.350 \text{ H6}$ **G variant example:**B081605-~~016~~.350-5Special tool diameter $d_1 = 16.350 -5 \mu\text{m}$

Dimensions of configurable series IT6

d_1	XS	l_1	l_2	z	SW
8,000-9,700	6	18	8	4	6
9,701-10,700	6	18	8	6	8
10,701-12,700	8	20	8	6	8
12,701-16,200	10	22	8	6	10
16,201-17,200	10	22	8	6	13
17,201-19,200	12	26	12	6	13
19,201-21,200	12	26	12	6	16
21,201-24,200	16	26	12	6	16
24,201-26,200	16	26	12	6	19
26,201-28,200	16	26	12	6	21
28,201-29,200	16	26	12	6	24
29,201-30,200	16	26	12	8	24
30,201-32,200	24	30	12	8	24
32,201-34,200	24	30	12	8	27
34,201-40,200	24	30	12	8	30

Dimensions in mm.

For cutting data recommendations, see end of chapter.

Associated XR replaceable head holders, see page 118.

XR 06 | B081661

Replaceable head reamer for blind bore, internal coolant supply

Design:

Diameter: 9.701 - 40.200 mm
 Cutting direction: Right-hand cutting
 Cutting material: Solid carbide,
 BSP-coated (HP145)
 Groove direction: Straight fluted
 Geometry: HPC geometry

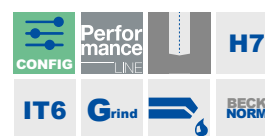
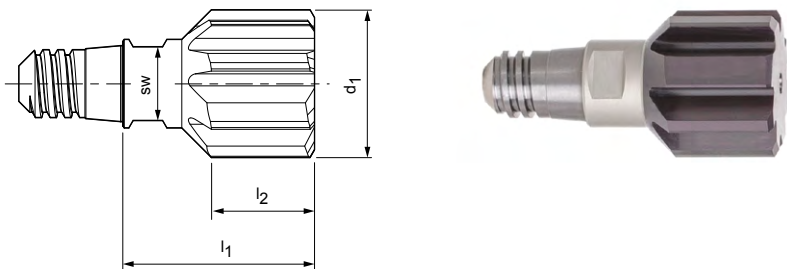

Preferred series in H7

Dimensions				z	AF	Order no.
d ₁ H7	XS	l ₁	l ₂			
10,000	6	18	10	6	6	30461250
10,500	6	18	10	6	6	30461259
11,000	6	20	10	6	6	30461261
11,500	6	20	10	6	6	30461263
12,000	6	20	10	6	6	30461267
12,500	6	20	10	6	6	30461271
13,000	6	22	12	6	6	30461273
14,000	6	22	12	6	6	30461274
15,000	8	22	12	6	8	30461275
16,000	8	22	12	6	8	30461276
17,000	10	22	12	8	10	30461278
18,000	10	26	14	8	10	30461279
19,000	10	26	14	8	10	30461281
20,000	10	26	14	8	10	30461283
21,000	12	26	14	8	13	30552644
22,000	12	26	14	8	13	30552645
23,000	12	26	14	8	13	30552646
24,000	12	26	14	8	13	30552648
25,000	16	26	14	8	16	30552649
26,000	16	26	14	8	16	30552650
27,000	16	26	14	8	16	30552651
28,000	16	26	14	8	16	30552652
29,000	16	26	14	8	16	30552653
30,000	16	26	14	8	16	30552654
31,000	16	30	14	8	16	30552655
32,000	16	30	14	8	16	30552656
33,000	16*	30	14	8	24	30552657
34,000	16*	30	14	8	24	30552658
35,000	16*	30	14	8	24	30552659
36,000	16*	30	14	8	24	30552660
37,000	16*	30	14	8	24	30552661
38,000	16*	30	14	8	24	30552662
39,000	16*	30	14	8	24	30552663
40,000	16*	30	14	8	24	30552664

Configurable features

**Bore diameter tolerance \geq IT6:**

- Diameter in increments of 0.001 mm freely selectable
- Can be ordered in tolerance \geq IT6

**Specification:**

B081661[Diameter][Tolerance]

G variant (see page 303):

- Diameter in increments of 0.001 mm freely selectable
- Can be ordered from tolerances $\geq 4 \mu\text{m}$

G variant specification:

B081661[Diameter][Tolerance]

IT6 tolerance example:

B081661-Ø16.350H6

Bore diameter $d_1 = 16.350 \text{ H6}$ **G variant example:**

B081661-Ø16.350-4

Special tool diameter $d_1 = 16.350 -4 \mu\text{m}$

Dimensions of configurable series IT6

d_1	XS	l_1	l_2	z	SW
9,701-10,700	6	18	10	6	6
10,701-12,700	6	20	10	6	6
12,701-14,200	6	22	12	6	6
14,201-16,200	8	22	12	6	8
16,201-17,200	10	22	12	8	10
17,201-20,200	10	26	14	8	10
20,201-24,200	12	26	14	8	13
24,201-30,200	16	26	14	8	16
30,201-32,200	16	30	14	8	16
32,201-40,200	16*	30	14	8	24

* Associated XR replaceable head holders with enlarged face connection for XS 16 from $\emptyset 32.201 \text{ mm}$, see page 118

XR 06 | B081662

Replaceable head reamer for blind bore, internal coolant supply

Design:

Diameter: 9.701 - 40.200 mm
 Cutting direction: Right-hand cutting
 Cutting material: Solid carbide, BVA-coated (HP145)
 Groove direction: Straight fluted
 Geometry: HPC geometry

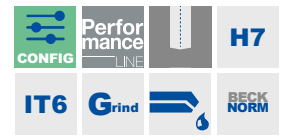
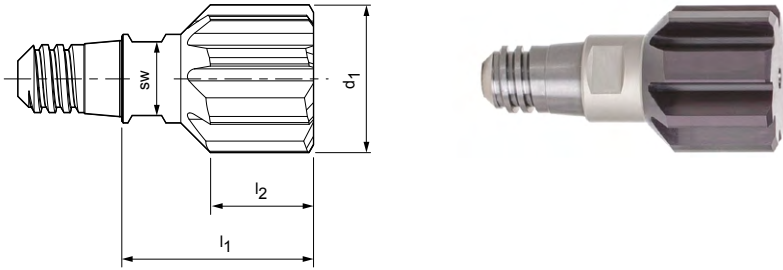

Preferred series in H7

Dimensions				z	AF	Order no.
d ₁ H7	XS	l ₁	l ₂			
10,000	6	18	10	6	6	30967391
10,500	6	18	10	6	6	30967392
11,000	6	20	10	6	6	30967393
11,500	6	20	10	6	6	30967394
12,000	6	20	10	6	6	30967395
12,500	6	20	10	6	6	30967396
13,000	6	22	12	6	6	30967397
14,000	6	22	12	6	6	30967398
15,000	8	22	12	6	8	30967399
16,000	8	22	12	6	8	30967400
17,000	10	22	12	8	10	30967401
18,000	10	26	14	8	10	30967402
19,000	10	26	14	8	10	30967403
20,000	10	26	14	8	10	30967404
21,000	12	26	14	8	13	30967405
22,000	12	26	14	8	13	30967406
23,000	12	26	14	8	13	30967407
24,000	12	26	14	8	13	30967408
25,000	16	26	14	8	16	30967409
26,000	16	26	14	8	16	30967410
27,000	16	26	14	8	16	30967411
28,000	16	26	14	8	16	30967412
29,000	16	26	14	8	16	30967413
30,000	16	26	14	8	16	30967414
31,000	16	30	14	8	16	30967415
32,000	16	30	14	8	16	30967416
33,000	16*	30	14	8	24	30967417
34,000	16*	30	14	8	24	30967418
35,000	16*	30	14	8	24	30967419
36,000	16*	30	14	8	24	30967420
37,000	16*	30	14	8	24	30967421
38,000	16*	30	14	8	24	30967422
39,000	16*	30	14	8	24	30967423
40,000	16*	30	14	8	24	30967424

Configurable features

**Bore diameter tolerance \geq IT6:**

- Diameter in increments of 0.001 mm freely selectable
- Can be ordered in tolerance \geq IT6

**Specification:**

B081662[Diameter][Tolerance]

G variant (see page 303):

- Diameter in increments of 0.001 mm freely selectable
- Can be ordered from tolerances $\geq 4 \mu\text{m}$

G variant specification:

B081662[Diameter][Tolerance]

IT6 tolerance example:B081662-~~00~~16.350H6Bore diameter $d_1 = 16.350 \text{ H6}$ **G variant example:**B081662-~~016~~.350-4Special tool diameter $d_1 = 16.350 -4 \mu\text{m}$

Dimensions of configurable series IT6

d_1	XS	l_1	l_2	z	SW
9,701-10,700	6	18	10	6	6
10,701-12,700	6	20	10	6	6
12,701-14,200	6	22	12	6	6
14,201-16,200	8	22	12	6	8
16,201-17,200	10	22	12	8	10
17,201-20,200	10	26	14	8	10
20,201-24,200	12	26	14	8	13
24,201-30,200	16	26	14	8	16
30,201-32,200	16	30	14	8	16
32,201-40,200	16*	30	14	8	24

* Associated XR replaceable head holders with enlarged face connection for XS 16 from $\emptyset 32.201 \text{ mm}$, see page 118

XR 06 | B081663

Replaceable head reamer for blind bore, internal coolant supply

Design:

Diameter: 9.701 - 40.200 mm
 Cutting direction: Right-hand cutting
 Cutting material: Solid carbide, BTI-coated (HP625)
 Groove direction: Straight fluted
 Geometry: HPC geometry

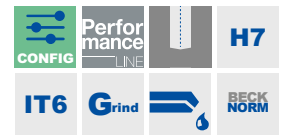
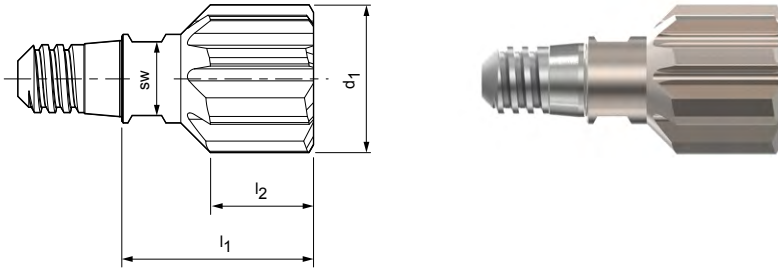

Preferred series in H7

Dimensions				z	AF	Order no.
d ₁ H7	XS	l ₁	l ₂			
10,000	6	18	10	6	6	30967425
10,500	6	18	10	6	6	30967426
11,000	6	20	10	6	6	30967427
11,500	6	20	10	6	6	30967428
12,000	6	20	10	6	6	30967429
12,500	6	20	10	6	6	30967430
13,000	6	22	12	6	6	30967431
14,000	6	22	12	6	6	30967432
15,000	8	22	12	6	8	30967433
16,000	8	22	12	6	8	30967434
17,000	10	22	12	8	10	30967435
18,000	10	26	14	8	10	30967436
19,000	10	26	14	8	10	30967437
20,000	10	26	14	8	10	30967438
21,000	12	26	14	8	13	30967439
22,000	12	26	14	8	13	30967440
23,000	12	26	14	8	13	30967441
24,000	12	26	14	8	13	30967442
25,000	16	26	14	8	16	30967443
26,000	16	26	14	8	16	30967444
27,000	16	26	14	8	16	30967445
28,000	16	26	14	8	16	30967446
29,000	16	26	14	8	16	30967447
30,000	16	26	14	8	16	30967448
31,000	16	30	14	8	16	30967449
32,000	16	30	14	8	16	30967450
33,000	16*	30	14	8	24	30967451
34,000	16*	30	14	8	24	30967452
35,000	16*	30	14	8	24	30967453
36,000	16*	30	14	8	24	30967454
37,000	16*	30	14	8	24	30967455
38,000	16*	30	14	8	24	30967456
39,000	16*	30	14	8	24	30967457
40,000	16*	30	14	8	24	30967458

Configurable features

**Bore diameter tolerance \geq IT6:**

- Diameter in increments of 0.001 mm freely selectable
- Can be ordered in tolerance \geq IT6

**Specification:**

B081663[Diameter][Tolerance]

G variant (see page 303):

- Diameter in increments of 0.001 mm freely selectable
- Can be ordered from tolerances $\geq 4 \mu\text{m}$

G variant specification:

B081663[Diameter][Tolerance]

IT6 tolerance example:B081663-~~00~~16.350H6Bore diameter $d_1 = 16.350 \text{ H6}$ **G variant example:**B081663-~~016~~.350-4Special tool diameter $d_1 = 16.350 -4 \mu\text{m}$

Dimensions of configurable series IT6

d_1	XS	l_1	l_2	z	SW
9,701-10,700	6	18	10	6	6
10,701-12,700	6	20	10	6	6
12,701-14,200	6	22	12	6	6
14,201-16,200	8	22	12	6	8
16,201-17,200	10	22	12	8	10
17,201-20,200	10	26	14	8	10
20,201-24,200	12	26	14	8	13
24,201-30,200	16	26	14	8	16
30,201-32,200	16	30	14	8	16
32,201-40,200	16*	30	14	8	24

* Associated XR replaceable head holders with enlarged face connection for XS 16 from $\emptyset 32.201 \text{ mm}$, see page 118

XR 06 | B081664

Replaceable head reamer for blind bore, internal coolant supply

Design:

Diameter: 9.701 - 40.200 mm
 Cutting direction: Right-hand cutting
 Cutting material: Solid carbide, BAL-coated (HP622)
 Groove direction: Straight fluted
 Geometry: HPC geometry

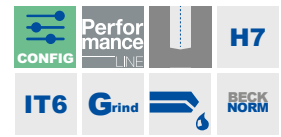
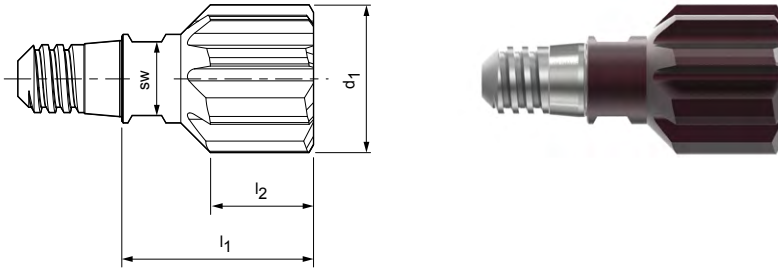

Preferred series in H7

Dimensions				z	AF	Order no.
d ₁ H7	XS	l ₁	l ₂			
10,000	6	18	10	6	6	30967459
10,500	6	18	10	6	6	30967460
11,000	6	20	10	6	6	30967461
11,500	6	20	10	6	6	30967462
12,000	6	20	10	6	6	30967463
12,500	6	20	10	6	6	30967464
13,000	6	22	12	6	6	30967465
14,000	6	22	12	6	6	30967466
15,000	8	22	12	6	8	30967467
16,000	8	22	12	6	8	30967468
17,000	10	22	12	8	10	30967469
18,000	10	26	14	8	10	30967470
19,000	10	26	14	8	10	30967471
20,000	10	26	14	8	10	30967472
21,000	12	26	14	8	13	30967473
22,000	12	26	14	8	13	30967474
23,000	12	26	14	8	13	30967475
24,000	12	26	14	8	13	30967476
25,000	16	26	14	8	16	30967477
26,000	16	26	14	8	16	30967478
27,000	16	26	14	8	16	30967479
28,000	16	26	14	8	16	30967480
29,000	16	26	14	8	16	30967481
30,000	16	26	14	8	16	30967482
31,000	16	30	14	8	16	30967483
32,000	16	30	14	8	16	30967484
33,000	16*	30	14	8	24	30967485
34,000	16*	30	14	8	24	30967486
35,000	16*	30	14	8	24	30967487
36,000	16*	30	14	8	24	30967488
37,000	16*	30	14	8	24	30967489
38,000	16*	30	14	8	24	30967491
39,000	16*	30	14	8	24	30967492
40,000	16*	30	14	8	24	30967493

Configurable features

**Bore diameter tolerance \geq IT6:**

- Diameter in increments of 0.001 mm freely selectable
- Can be ordered in tolerance \geq IT6

**Specification:**B081664[**Diameter**][**Tolerance**]**G variant** (see page 303):

- Diameter in increments of 0.001 mm freely selectable
- Can be ordered from tolerances $\geq 4 \mu\text{m}$

G variant specification:B081664[**Diameter**][**Tolerance**]**IT6 tolerance example:**B081664-~~00~~**16.350H6**Bore diameter $d_1 = 16.350 \text{ H6}$ **G variant example:**B081664-~~016.350~~-**4**Special tool diameter $d_1 = 16.350 -4 \mu\text{m}$

Dimensions of configurable series IT6

d_1	XS	l_1	l_2	z	SW
9,701-10,700	6	18	10	6	6
10,701-12,700	6	20	10	6	6
12,701-14,200	6	22	12	6	6
14,201-16,200	8	22	12	6	8
16,201-17,200	10	22	12	8	10
17,201-20,200	10	26	14	8	10
20,201-24,200	12	26	14	8	13
24,201-30,200	16	26	14	8	16
30,201-32,200	16	30	14	8	16
32,201-40,200	16*	30	14	8	24

* Associated XR replaceable head holders with enlarged face connection for XS 16 from $\emptyset 32.201 \text{ mm}$, see page 118

XR 06 | B081669

Replaceable head reamer for blind bore, internal coolant supply

Design:

Diameter: 9.701 - 40.200 mm
 Cutting direction: Right-hand cutting
 Cutting material: Solid carbide, CVD-coated (HC419)
 Groove direction: Straight fluted
 Geometry: HPC geometry

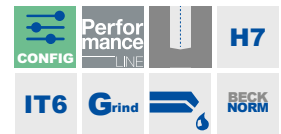
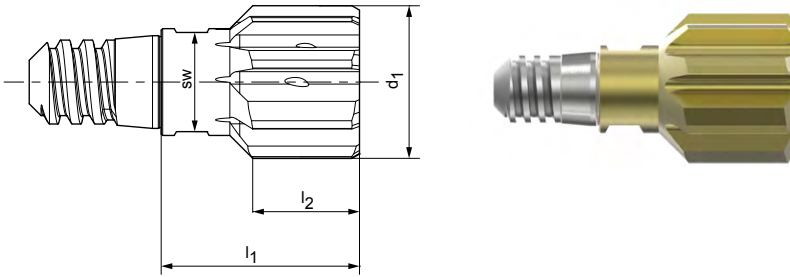

Preferred series in H7

Dimensions				z	AF	Order no.
d ₁ H7	XS	l ₁	l ₂			
10,000	6	18	10	6	6	30998244
10,500	6	18	10	6	6	30998245
11,000	6	20	10	6	6	30998246
11,500	6	20	10	6	6	30998247
12,000	6	20	10	6	6	30998248
12,500	6	20	10	6	6	30998249
13,000	6	22	12	6	6	30998250
14,000	6	22	12	6	6	30998251
15,000	8	22	12	6	8	30998252
16,000	8	22	12	6	8	30998253
17,000	10	22	12	8	10	30998254
18,000	10	26	14	8	10	30998255
19,000	10	26	14	8	10	30998256
20,000	10	26	14	8	10	30998257
21,000	12	26	14	8	13	30998258
22,000	12	26	14	8	13	30998259
23,000	12	26	14	8	13	30998260
24,000	12	26	14	8	13	30998261
25,000	16	26	14	8	16	30998262
26,000	16	26	14	8	16	30998263
27,000	16	26	14	8	16	30998264
28,000	16	26	14	8	16	30998265
29,000	16	26	14	8	16	30998266
30,000	16	26	14	8	16	30998267
31,000	16	30	14	8	16	30998268
32,000	16	30	14	8	16	30998269
33,000	16*	30	14	8	24	30998280
34,000	16*	30	14	8	24	30998281
35,000	16*	30	14	8	24	30998282
36,000	16*	30	14	8	24	30998283
37,000	16*	30	14	8	24	30998284
38,000	16*	30	14	8	24	30998285
39,000	16*	30	14	8	24	30998286
40,000	16*	30	14	8	24	30998291

Configurable features

**Bore diameter tolerance \geq IT6:**

- Diameter in increments of 0.001 mm freely selectable
- Can be ordered in tolerance \geq IT6

**Specification:**

B081669[Diameter][Tolerance]

G variant (see page 303):

- Diameter in increments of 0.001 mm freely selectable
- Can be ordered from tolerances $\geq 4 \mu\text{m}$

G variant specification:

B081669[Diameter][Tolerance]

IT6 tolerance example:B081669-~~00~~16.350H6Bore diameter $d_1 = 16.350 \text{ H6}$ **G variant example:**B081669-~~016~~.350-4Special tool diameter $d_1 = 16.350 -4 \mu\text{m}$

Dimensions of configurable series IT6

d_1	XS	l_1	l_2	z	SW
9,701-10,700	6	18	10	6	6
10,701-12,700	6	20	10	6	6
12,701-14,200	6	22	12	6	6
14,201-16,200	8	22	12	6	8
16,201-17,200	10	22	12	8	10
17,201-20,200	10	26	14	8	10
20,201-24,200	12	26	14	8	13
24,201-30,200	16	26	14	8	16
30,201-32,200	16	30	14	8	16
32,201-40,200	16*	30	14	8	24

* Associated XR replaceable head holders with enlarged face connection for XS 16 from $\emptyset 32.201 \text{ mm}$, see page 118

XR 01 | B081650

Replaceable head reamer for blind bore with brazed blades, internal coolant supply

Design:

Diameter: 12.201 - 40.200 mm
 Cutting direction: Right-hand cutting
 Cutting material: Carbide, uncoated (HU612)
 Groove direction: Straight fluted
 Lead angle: 60°
 Rake angle: 0°

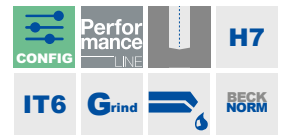
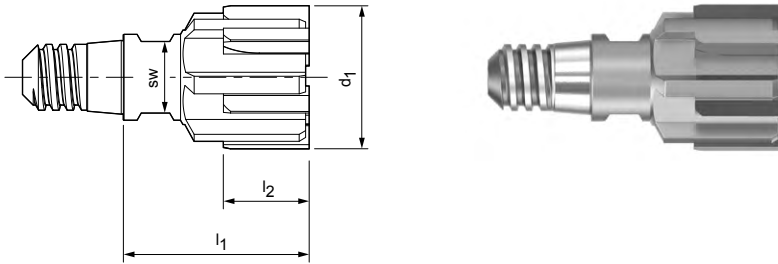

Preferred series in H7

Dimensions				z	AF	Order no.
d ₁ H7	XS	l ₁	l ₂			
14,000	6	22	8	6	6	30383271
16,000	8	22	8	6	8	30383272
18,000	10	26	12	6	10	30383273
20,000	10	26	12	6	10	30383274
22,000	12	26	12	6	13	30383275
24,000	12	26	12	6	13	30383276
25,000	16	26	12	6	16	30383277
26,000	16	26	12	6	16	30383278
28,000	16	26	12	6	16	30383279
30,000	16	26	12	8	16	30383280
32,000	16	30	12	8	16	30455254
34,000	24	30	12	8	24	30455256
36,000	24	30	12	8	24	30455257
38,000	24	30	12	8	24	30455258
40,000	24	30	12	8	24	30455259

Configurable features

**Bore diameter tolerance \geq IT6:**

- Diameter in increments of 0.001 mm freely selectable
- Can be ordered in tolerance \geq IT6

**Specification:**

B081650[Diameter][Tolerance]

G variant (see page 303):

- Diameter in increments of 0.001 mm freely selectable
- Can be ordered from tolerances $\geq 5 \mu\text{m}$

G variant specification:

B081650[Diameter][Tolerance]

Dimensions of configurable series IT6

d_1	XS	l_1	l_2	z	SW
12,201-12,700	6	20	8	6	6
12,701-14,200	6	22	8	6	6
14,201-16,200	8	22	8	6	8
16,201-17,200	10	22	8	6	10
17,201-20,200	10	26	12	6	10
20,201-24,200	12	26	12	6	13
24,201-29,200	16	26	12	6	16
29,201-30,200	16	26	12	8	16
30,201-32,200	16	30	12	8	16
32,201-40,200	24	30	12	8	24

IT6 tolerance example:B081650-~~00~~16.350H6Bore diameter $d_1 = 16.350 \text{ H6}$ **G variant example:**B081650-~~016~~.350-5Special tool diameter $d_1 = 16.350 -5 \mu\text{m}$

XR 01 | B081651

Replaceable head reamer for blind bore with brazed blades, internal coolant supply

Design:

Diameter: 12.201 - 40.200 mm
 Cutting direction: Right-hand cutting
 Cutting material: Carbide, BSP-coated (HP421)
 Groove direction: Straight fluted
 Lead angle: 60°
 Rake angle: 0°

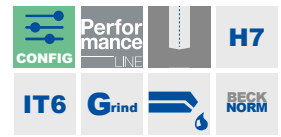
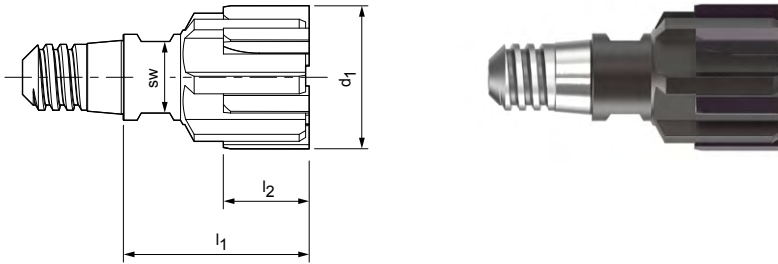

Preferred series in H7

Dimensions				z	AF	Order no.
d ₁ H7	XS	l ₁	l ₂			
14,000	6	22	8	6	6	30383259
16,000	8	22	8	6	8	30383260
18,000	10	26	12	6	10	30383261
20,000	10	26	12	6	10	30383262
22,000	12	26	12	6	13	30383263
24,000	12	26	12	6	13	30383264
25,000	16	26	12	6	16	30383265
26,000	16	26	12	6	16	30383267
28,000	16	26	12	6	16	30383268
30,000	16	26	12	8	16	30383269
32,000	16	30	12	8	16	30455248
34,000	24	30	12	8	24	30455250
36,000	24	30	12	8	24	30455251
38,000	24	30	12	8	24	30455252
40,000	24	30	12	8	24	30455253

Configurable features

**Bore diameter tolerance \geq IT6:**

- Diameter in increments of 0.001 mm freely selectable
- Can be ordered in tolerance \geq IT6

**Specification:**

B081651[Diameter][Tolerance]

G variant (see page 303):

- Diameter in increments of 0.001 mm freely selectable
- Can be ordered from tolerances $\geq 5 \mu\text{m}$

G variant specification:

B081651[Diameter][Tolerance]

Dimensions of configurable series IT6

d_1	XS	l_1	l_2	z	SW
12,201-12,700	6	20	8	6	6
12,701-14,200	6	22	8	6	6
14,201-16,200	8	22	8	6	8
16,201-17,200	10	22	8	6	10
17,201-20,200	10	26	12	6	10
20,201-24,200	12	26	12	6	13
24,201-29,200	16	26	12	6	16
29,201-30,200	16	26	12	8	16
30,201-32,200	16	30	12	8	16
32,201-40,200	24	30	12	8	24

IT6 tolerance example:B081651-**Ø16.350H6**Bore diameter $d_1 = 16.350 \text{ H6}$ **G variant example:**B081651-**Ø16.350-5**Special tool diameter $d_1 = 16.350 -5 \mu\text{m}$

XR 01 | B081659

Replaceable head reamer for blind bore with brazed blades, internal coolant supply

Design:

Diameter: 12.201 - 40.200 mm
 Cutting direction: Right-hand cutting
 Cutting material: Carbide, BVA-coated (HP421)
 Groove direction: Straight fluted
 Lead angle: 60°
 Rake angle: 0°

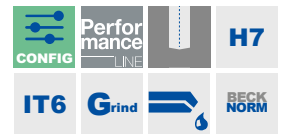
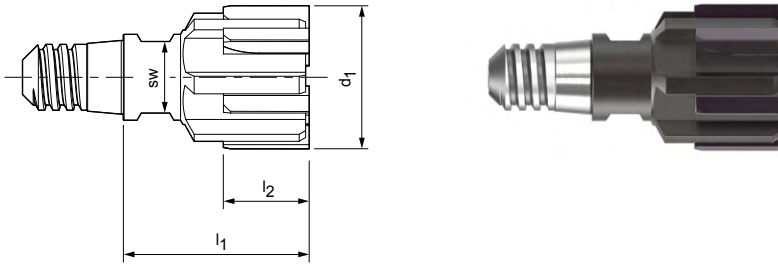

Preferred series in H7

Dimensions				z	AF	Order no.
d ₁ H7	XS	l ₁	l ₂			
14,000	6	22	8	6	6	30383248
16,000	8	22	8	6	8	30383249
18,000	10	26	12	6	10	30383250
20,000	10	26	12	6	10	30383251
22,000	12	26	12	6	13	30383252
24,000	12	26	12	6	13	30383253
25,000	16	26	12	6	16	30383254
26,000	16	26	12	6	16	30383255
28,000	16	26	12	6	16	30383256
30,000	16	26	12	8	16	30383257
32,000	16	30	12	8	16	30455243
34,000	24	30	12	8	24	30455244
36,000	24	30	12	8	24	30455245
38,000	24	30	12	8	24	30455246
40,000	24	30	12	8	24	30455247

Configurable features

**Bore diameter tolerance \geq IT6:**

- Diameter in increments of 0.001 mm freely selectable
- Can be ordered in tolerance \geq IT6

**Specification:**

B081659[Diameter][Tolerance]

G variant (see page 303):

- Diameter in increments of 0.001 mm freely selectable
- Can be ordered from tolerances $\geq 5 \mu\text{m}$

G variant specification:

B081659[Diameter][Tolerance]

Dimensions of configurable series IT6

d_1	XS	l_1	l_2	z	SW
12,201-12,700	6	20	8	6	6
12,701-14,200	6	22	8	6	6
14,201-16,200	8	22	8	6	8
16,201-17,200	10	22	8	6	10
17,201-20,200	10	26	12	6	10
20,201-24,200	12	26	12	6	13
24,201-29,200	16	26	12	6	16
29,201-30,200	16	26	12	8	16
30,201-32,200	16	30	12	8	16
32,201-40,200	24	30	12	8	24

IT6 tolerance example:B081659-~~00~~16.350H6Bore diameter $d_1 = 16.350 \text{ H6}$ **G variant example:**B081659-~~016~~.350-5Special tool diameter $d_1 = 16.350 -5 \mu\text{m}$

XR 01 | B081652

Replaceable head reamer for blind bore with brazed blades, internal coolant supply

Design:

Diameter: 12.201 - 40.200 mm
 Cutting direction: Right-hand cutting
 Cutting material: Cermet, uncoated (CU130)
 Groove direction: Straight fluted
 Lead angle: 60°
 Rake angle: 0°

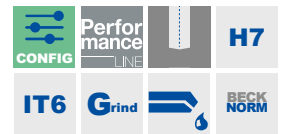
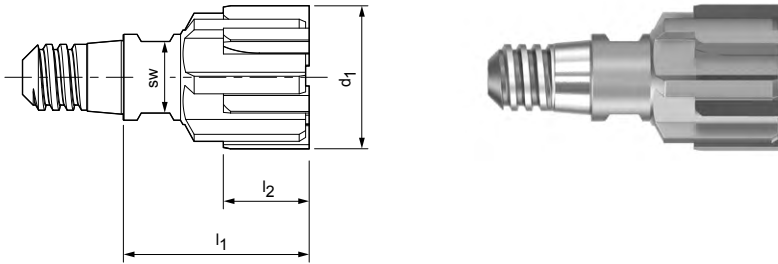

Preferred series in H7

Dimensions				z	AF	Order no.
d ₁ H7	XS	l ₁	l ₂			
14,000	6	22	8	6	6	30383237
16,000	8	22	8	6	8	30383238
18,000	10	26	12	6	10	30383239
20,000	10	26	12	6	10	30383240
22,000	12	26	12	6	13	30383241
24,000	12	26	12	6	13	30383242
25,000	16	26	12	6	16	30383243
26,000	16	26	12	6	16	30383244
28,000	16	26	12	6	16	30383245
30,000	16	26	12	8	16	30383246
32,000	16	30	12	8	16	30455238
34,000	24	30	12	8	24	30455239
36,000	24	30	12	8	24	30455240
38,000	24	30	12	8	24	30455241
40,000	24	30	12	8	24	30455242

Configurable features

**Bore diameter tolerance \geq IT6:**

- Diameter in increments of 0.001 mm freely selectable
- Can be ordered in tolerance \geq IT6

**Specification:**B081652[**Diameter**][**Tolerance**]**G variant** (see page 303):

- Diameter in increments of 0.001 mm freely selectable
- Can be ordered from tolerances $\geq 5 \mu\text{m}$

G variant specification:B081652[**Diameter**][**Tolerance**]

Dimensions of configurable series IT6

d_1	XS	l_1	l_2	z	SW
12,201-12,700	6	20	8	6	6
12,701-14,200	6	22	8	6	6
14,201-16,200	8	22	8	6	8
16,201-17,200	10	22	8	6	10
17,201-20,200	10	26	12	6	10
20,201-24,200	12	26	12	6	13
24,201-29,200	16	26	12	6	16
29,201-30,200	16	26	12	8	16
30,201-32,200	16	30	12	8	16
32,201-40,200	24	30	12	8	24

IT6 tolerance example:B081652-**Ø16.350H6**Bore diameter $d_1 = 16.350 \text{ H6}$ **G variant example:**B081652-**Ø16.350-5**Special tool diameter $d_1 = 16.350 -5 \mu\text{m}$

XR 01 | B081655

Replaceable head reamer for blind bore with brazed blades, internal coolant supply

Design:

Diameter: 12.201 - 40.200 mm
 Cutting direction: Right-hand cutting
 Cutting material: PCD cutting blades (PU620)
 Groove direction: Straight fluted
 Lead angle: 75°
 Rake angle: 0°

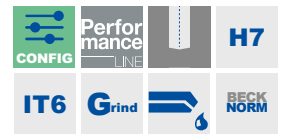
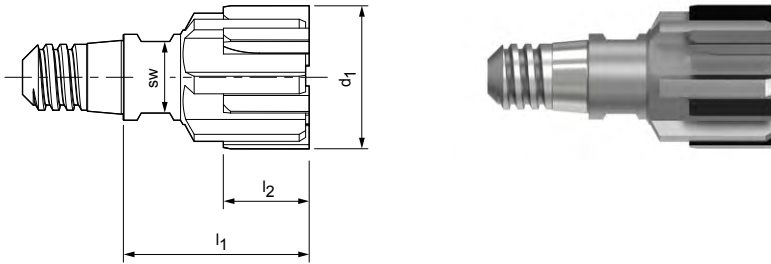

Preferred series in H7

Dimensions				z	AF	Order no.
d ₁ H7	XS	l ₁	l ₂			
14,000	6	22	8	6	6	30383282
16,000	8	22	8	6	8	30383283
18,000	10	26	12	6	10	30383284
20,000	10	26	12	6	10	30383285
22,000	12	26	12	6	13	30383286
24,000	12	26	12	6	13	30383287
25,000	16	26	12	6	16	30383288
26,000	16	26	12	6	16	30383289
28,000	16	26	12	6	16	30383290
30,000	16	26	12	8	16	30383291
32,000	16	30	12	8	16	30455260
34,000	24	30	12	8	24	30455261
36,000	24	30	12	8	24	30455262
38,000	24	30	12	8	24	30455263
40,000	24	30	12	8	24	30455264

Configurable features

**Bore diameter tolerance \geq IT6:**

- Diameter in increments of 0.001 mm freely selectable
- Can be ordered in tolerance \geq IT6

**Specification:**B081655[**Diameter**][**Tolerance**]**G variant** (see page 303):

- Diameter in increments of 0.001 mm freely selectable
- Can be ordered from tolerances $\geq 5 \mu\text{m}$

G variant specification:B081655[**Diameter**][**Tolerance**]

Dimensions of configurable series IT6

d_1	XS	l_1	l_2	z	SW
12,201-12,700	6	20	8	6	6
12,701-14,200	6	22	8	6	6
14,201-16,200	8	22	8	6	8
16,201-17,200	10	22	8	6	10
17,201-20,200	10	26	12	6	10
20,201-24,200	12	26	12	6	13
24,201-29,200	16	26	12	6	16
29,201-30,200	16	26	12	8	16
30,201-32,200	16	30	12	8	16
32,201-40,200	24	30	12	8	24

IT6 tolerance example:B081655-**0016.350H6**Bore diameter $d_1 = 16.350 \text{ H6}$ **G variant example:**B081655-**016.350-5**Special tool diameter $d_1 = 16.350 -5 \mu\text{m}$

XR replaceable head holder | B085101 | B085301

Cylindrical shank design with XS connection, internal coolant supply

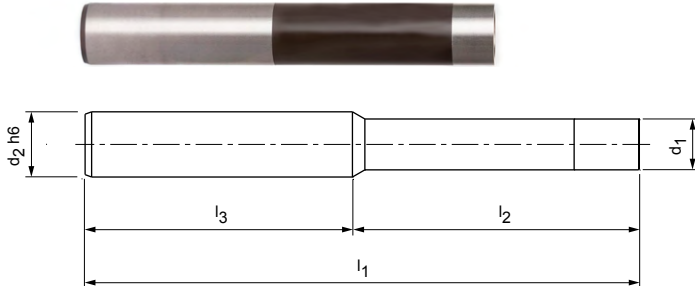

Preferred series available from stock

Dimensions						Specification	Order no.
d ₁	XS	d ₂ h6	l ₁	l ₂	l ₃		
7,800	6	10	60	20	40	B085101-XS06-020	30350736
7,800	6	10	85	45	40	B085101-XS06-045	30350737
7,800	6	10	150	110	40	B085101-XS06-110	30350738
9,800	8	12	70	25	45	B085101-XS08-025	30350742
9,800	8	12	90	45	45	B085101-XS08-045	30350743
9,800	8	12	150	105	45	B085101-XS08-105	30350744
11,800	10	16	70	22	48	B085101-XS10-022	30350747
11,800	10	16	90	42	48	B085101-XS10-042	30350748
11,800	10	16	150	102	48	B085101-XS10-102	30350749
15,800	12	16	80	32	48	B085101-XS12-032	30350752
15,800	12	16	105	57	48	B085101-XS12-057	30350753
15,800	12	16	150	102	48	B085101-XS12-102	30350754
15,800	12	16	200	152	48	B085101-XS12-152	30350755
19,800	16*	25	90	34	56	B085101-XS16-034	30350758
19,800	16*	25	120	64	56	B085101-XS16-064	30350759
19,800	16*	25	200	144	56	B085101-XS16-144	30350760
19,800	16*	25	250	194	56	B085101-XS16-194	30350761
27,800	24	32	90	30	60	B085101-XS24-030	30371461
27,800	24	32	120	60	60	B085101-XS24-060	30371464
27,800	24	32	200	140	60	B085101-XS24-140	30371467

With enlarged face connection for solid carbide replaceable heads XR 06 from ø 27.201 for through bore and from ø 32.201 for blind bore

26,000	16	25	90	34	56	B085301-XS16-034	30839581
26,000	16	25	120	64	56	B085301-XS16-064	30839582
26,000	16	25	200	144	56	B085301-XS16-144	30839583
26,000	16	25	250	194	56	B085301-XS16-194	30839584

Dimensions in mm.

* For solid carbide replaceable heads XR 06 from ø 27.201 (for through bore) and from ø 32.201 mm (for blind bore), use tool holder with enlarged face connection (see table below)!

Torque wrench for combination wrench

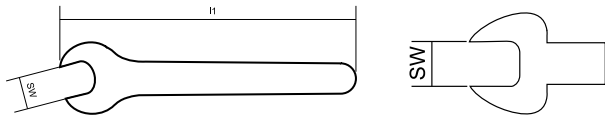

Torque wrench for combination wrench

AF	Order No. Installation wrench	Order No. Combination wrench
6	30352660	30376387
8	30352661	30376388
10	30352662	30376390
13	30352663	30376392
16	30352667	30376394
19	30394085	30394090
21	30352668	30376395
24	30352669	30376396
27	30394086	30394091
30	30394087	30394092

Attachment shank	Torque (Nm)	Total length	Order number
9x12	2-25	274,0	30386735
14x18	20-200	470,5	30386736

Cutting data recommendations for HNC reamers

Feed f [mm/U], cutting speed v_c [m/min] and stock removal a [mm]

HNC-Plus | B043555, B043565, B043575, B043585

ZG*	Workpiece material		Strength/hardness [N/mm ²] [HRC]	
P	P1	P1.1 Structural, machining, case hardened and tempering steels, unalloyed	< 700	
		P1.2 Structural, machining, case hardened and tempering steels, unalloyed	< 1,200	
	P2	P2.1 Nitriding, hardening and tempering steels, alloyed	< 900	
		P2.2 Nitriding, hardening and tempering steels, alloyed	< 1,400	
	P3	P3.1 Tool, bearing, spring and high-speed steels**	< 800	
		P3.2 Tool, bearing, spring and high-speed steels**	< 1,000	
		P3.3 Tool, bearing, spring and high-speed steels**	< 1,500	
	P4	P4.1 Stainless steels, ferritic and martensitic		
P5	P5.1 Cast steel			
P6	P6.1 Stainless cast steels, ferritic and martensitic			
M	M1	M1.1 Stainless steels, austenitic	< 700	
		M1.2 Stainless steels, ferritic/austenitic (duplex)	< 1,000	
	M2	M2.1 Stainless cast steel, austenitic	< 700	
		M3 M3.1 Stainless cast steel, ferritic/austenitic (duplex)	< 1,000	
K	K1	K1.1 Cast iron with lamellar graphite (grey cast iron), GJL	< 300	
		K2.1 Cast iron with spheroidal graphite, GJS	< 500	
		K2.2 Cast iron with spheroidal graphite, GJS	≤ 800	
	K2	K2.3 Cast iron with spheroidal graphite, GJS	> 800	
		K3	K3.1 Cast iron with vermicular graphite, GJV; malleable cast iron, GJM	< 500
			K3.2 Cast iron with vermicular graphite, GJV; malleable cast iron, GJM	> 500
N	N1	N1.1 Aluminium, unalloyed and alloyed < 3% Si		
		N1.2 Aluminium, alloyed ≤ 7% Si		
		N1.3 Aluminium, alloyed > 7-12% Si		
		N1.4 Aluminium, alloyed > 12% Si	< 300	
S	S1	S1.1 Titanium, titanium alloys	< 400	
		S2.1 Titanium, titanium alloys	> 1,200	
	S2	S2.2 Titanium, titanium alloys	< 1,200	
		S3	S3.1 Nickel, unalloyed and alloyed	> 900
	S3.2 Nickel, unalloyed and alloyed		> 900	
	S4	S4.1 High-temperature super alloy, Ni-, Co-, and Fe-based		
S5	S5.1 Wolfram and molybdenum alloy			
H	H1	H1.1 Hardened steel / Cast steel	< 44	
		H1.2 Hardened steel / Cast steel	< 55	

* BECK machining groups

** If the alloy parts Cr, Mo, Ni, V, W in total > 8%, then select the next highest BECK machining group.

	V _c	Application data for ø [mm]											
		< 5.701		> 5.701-6.2		> 6.2-8		> 8-12		> 12-16.2		> 16.2-20.2	
		f	a	f	a	f	a	f	a	f	a	f	a
	180	0.60	0.10	1.00	0.10	1.20	0.10	1.20	0.15	1.50	0.20	1.80	0.20
	150	0.40	0.10	0.80	0.10	1.00	0.10	1.00	0.15	1.20	0.20	1.50	0.20
	180	0.60	0.10	1.00	0.10	1.20	0.10	1.20	0.15	1.50	0.20	1.80	0.20
	140	0.30	0.10	0.60	0.10	0.80	0.10	0.80	0.15	1.00	0.20	1.20	0.20
	180	0.60	0.10	1.00	0.10	1.20	0.10	1.20	0.15	1.50	0.20	1.80	0.20
	160	0.40	0.10	0.80	0.10	1.00	0.10	1.00	0.15	1.20	0.20	1.50	0.20
	140	0.30	0.10	0.60	0.10	0.80	0.10	0.80	0.15	1.00	0.20	1.20	0.20
	40	0.10	0.05	0.15	0.10	0.30	0.10	0.40	0.10	0.50	0.20	0.60	0.20
	140	0.30	0.10	0.60	0.10	0.80	0.10	0.80	0.15	1.00	0.20	1.20	0.20
	40	0.10	0.05	0.15	0.10	0.30	0.10	0.40	0.10	0.50	0.20	0.60	0.20
	50	0.15	0.05	0.20	0.10	0.40	0.10	0.50	0.10	0.70	0.20	0.80	0.20
	40	0.15	0.05	0.20	0.10	0.40	0.10	0.50	0.10	0.70	0.20	0.80	0.20
	50	0.15	0.05	0.20	0.10	0.40	0.10	0.50	0.10	0.70	0.20	0.80	0.20
	40	0.15	0.05	0.20	0.10	0.40	0.10	0.50	0.10	0.70	0.20	0.80	0.20
	100	0.50	0.10	1.20	0.10	1.20	0.10	1.50	0.20	1.80	0.20	1.80	0.20
	100	0.50	0.10	1.20	0.10	1.20	0.10	1.50	0.20	1.80	0.20	1.80	0.20
	100	0.50	0.10	1.20	0.10	1.20	0.10	1.50	0.20	1.80	0.20	1.80	0.20
	100	0.50	0.10	1.20	0.10	1.20	0.10	1.50	0.20	1.80	0.20	1.80	0.20
	100	0.50	0.10	1.20	0.10	1.20	0.10	1.50	0.20	1.80	0.20	1.80	0.20
	100	0.50	0.10	1.20	0.10	1.20	0.10	1.50	0.20	1.80	0.20	1.80	0.20
	250	0.50	0.10	0.60	0.10	0.80	0.10	1.30	0.20	1.50	0.30	1.80	0.30
	250	0.50	0.10	0.60	0.10	0.80	0.10	1.30	0.20	1.50	0.30	1.80	0.30
	250	0.50	0.10	0.60	0.10	0.80	0.10	1.30	0.20	1.50	0.30	1.80	0.30
	250	0.50	0.10	0.60	0.10	0.80	0.10	1.30	0.20	1.50	0.30	1.80	0.30
	20	0.20	0.05	0.30	0.05	0.30	0.10	0.30	0.10	0.30	0.15	0.30	0.20
	20	0.20	0.05	0.30	0.05	0.30	0.10	0.30	0.10	0.30	0.15	0.30	0.20
	20	0.20	0.05	0.30	0.05	0.30	0.10	0.30	0.10	0.30	0.15	0.30	0.20
	20	0.20	0.05	0.30	0.05	0.30	0.10	0.30	0.10	0.30	0.15	0.30	0.20
	20	0.20	0.05	0.30	0.05	0.30	0.10	0.30	0.10	0.30	0.15	0.30	0.20
	20	0.20	0.05	0.30	0.05	0.30	0.10	0.30	0.10	0.30	0.15	0.30	0.20
	20	0.20	0.05	0.30	0.05	0.30	0.10	0.30	0.10	0.30	0.15	0.30	0.20
	10	0.06	0.05	0.10	0.05	0.12	0.05	0.12	0.10	0.18	0.10	0.18	0.20
	10	0.06	0.05	0.10	0.05	0.12	0.05	0.12	0.10	0.18	0.10	0.18	0.20

The specified cutting data are guide values.

The optimum data for the respective machining task should be determined during the test or machining.

Cutting data recommendations for HNC reamers

Feed f [mm/U], cutting speed v_c [m/min] and stock removal a [mm]

HNC | B040260

Cutting material: Solid carbide, uncoated

HNC | B040261

Cutting material: Solid carbide, uncoated

ZG*	Workpiece material	Strength/hardness [N/mm ²] [HRC]	Application data for ϕ [mm]						
			< 5			5-6.2			
			v_c	f	a	v_c	f	a	
N	N1	N1.1 Aluminium, unalloyed and alloyed < 3% Si	50	0.15	0.15	50	0.15	0.15	
		N1.2 Aluminium, alloyed \leq 7% Si	50	0.15	0.15	50	0.15	0.15	
		N1.3 Aluminium, alloyed > 7-12% Si	30	0.15	0.15	30	0.15	0.15	
		N1.4 Aluminium, alloyed > 12% Si	30	0.15	0.15	30	0.15	0.15	
	N2	N2.1 Copper, unalloyed and low alloyed	< 300 N/mm ²	50	0.15	0.10	50	0.18	0.10
		N2.2 Copper, alloyed	> 300 N/mm ²	50	0.15	0.10	50	0.18	0.10
		N2.3 Brass, bronze, gunmetal	< 1200 N/mm ²	50	0.15	0.10	50	0.18	0.10
	N4	N4.1 Plastic, thermoplastics		40	0.15	0.15	40	0.15	0.15
		N4.2 Plastic, duroplastics		40	0.15	0.15	40	0.15	0.15
		N4.3 Plastic, foam materials		40	0.15	0.15	40	0.15	0.15

HNC-Speed | B043260

Cutting material: Solid carbide, BSP-coated

HNC-Speed | B043261

Cutting material: Solid carbide, BSP-coated

ZG*	Workpiece material	Strength/hardness [N/mm ²] [HRC]	Application data for ϕ [mm]						
			< 5			5-6.2			
			v_c	f	a	v_c	f	a	
P	P1	P1.1 Structural, machining, case hardened and tempering steels, unalloyed	< 700 N/mm ²	180	0.20	0.10	180	0.30	0.10
		P1.2 Structural, machining, case hardened and tempering steels, unalloyed	< 1200 N/mm ²	140	0.20	0.10	140	0.30	0.10
	P2	P2.1 Nitriding, hardening and tempering steels, alloyed	< 900 N/mm ²	180	0.20	0.10	180	0.30	0.10
		P2.2 Nitriding, hardening and tempering steels, alloyed	< 1400 N/mm ²	140	0.20	0.10	140	0.30	0.10
	P3	P3.1 Tool steels, roller bearing steels, spring steels and high-speed steels	< 900 N/mm ²	180	0.20	0.10	180	0.30	0.10
		P3.2 Tool steels, roller bearing steels, spring steels and high-speed steels	< 1500 N/mm ²	140	0.20	0.10	140	0.30	0.10
	P5	P5.1 Cast steel		140	0.20	0.10	140	0.30	0.10
K	K1	K1.1 Cast iron with lamellar graphite (grey cast iron), GJL	< 300 N/mm ²	110	0.30	0.10	110	0.40	0.10
		K2.1 Cast iron with spheroidal graphite, GJS	< 500 N/mm ²	150	0.30	0.10	150	0.40	0.10
	K2	K2.2 Cast iron with spheroidal graphite, GJS	500-800 N/mm ²	90	0.30	0.10	90	0.40	0.10
		K2.3 Cast iron with spheroidal graphite, GJS	> 800 N/mm ²	90	0.30	0.10	90	0.40	0.10
	K3	K3.1 Cast iron with vermicular graphite, GJV; malleable cast iron, GJM	< 500 N/mm ²	90	0.30	0.10	90	0.40	0.10
		K3.2 Cast iron with vermicular graphite, GJV; malleable cast iron, GJM	> 500 N/mm ²	90	0.30	0.10	90	0.40	0.10

Application data for ϕ [mm]												
> 6.2-8			> 8-12			> 12-16.2			> 16.2-20.2			
v_c	f	a	v_c	f	a	v_c	f	a	v_c	f	a	
50	0.15	0.15	50	0.20	0.20	50	0.20	0.20	50	0.30	0.30	
50	0.15	0.15	50	0.20	0.20	50	0.20	0.20	50	0.30	0.30	
30	0.15	0.15	30	0.20	0.20	30	0.20	0.20	30	0.30	0.30	
30	0.15	0.15	30	0.20	0.20	30	0.20	0.20	30	0.30	0.30	
50	0.18	0.10	50	0.20	0.20	50	0.30	0.20	50	0.35	0.30	
50	0.18	0.10	50	0.20	0.20	50	0.30	0.20	50	0.35	0.30	
50	0.18	0.10	50	0.20	0.20	50	0.30	0.20	50	0.35	0.30	
40	0.15	0.15	40	0.35	0.20	40	0.35	0.20	40	0.40	0.30	
40	0.15	0.15	40	0.35	0.20	40	0.35	0.20	40	0.40	0.30	
40	0.15	0.15	40	0.35	0.20	40	0.35	0.20	40	0.40	0.30	

Application data for ϕ [mm]												
> 6.2-8			> 8-12			> 12-16.2			> 16.2-20.2			
v_c	f	a	v_c	f	a	v_c	f	a	v_c	f	a	
180	0.50	0.10	180	0.80	0.15	180	1.10	0.20	180	1.50	0.20	
140	0.50	0.10	140	0.80	0.15	140	1.10	0.20	140	1.50	0.20	
180	0.50	0.10	180	0.80	0.15	180	1.10	0.20	180	1.50	0.20	
140	0.50	0.10	140	0.80	0.15	140	1.10	0.20	140	1.50	0.20	
180	0.50	0.10	180	0.80	0.15	180	1.10	0.20	180	1.50	0.20	
140	0.50	0.10	140	0.80	0.15	140	1.10	0.20	140	1.50	0.20	
140	0.50	0.10	140	0.80	0.15	140	1.10	0.20	140	1.50	0.20	
110	0.60	0.10	110	1.00	0.20	110	1.30	0.20	110	1.80	0.30	
150	0.60	0.15	150	1.00	0.20	150	1.30	0.20	150	1.80	0.30	
90	0.60	0.15	90	1.00	0.20	90	1.30	0.20	90	1.80	0.30	
90	0.60	0.15	90	1.00	0.20	90	1.30	0.20	90	1.80	0.30	
90	0.60	0.15	90	1.00	0.20	90	1.30	0.20	90	1.80	0.30	
90	0.60	0.15	90	1.00	0.20	90	1.30	0.20	90	1.80	0.30	

The specified cutting data are guide values.

The optimum data for the respective machining task should be determined during the test or machining.

Cutting data recommendations for HNC reamers

Feed f [mm/U], cutting speed v_c [m/min] and stock removal a [mm]

HNC-VA | B043270

Cutting material: Solid carbide, BVA-coated

HNC-VA | B043271

Cutting material: Solid carbide, BVA-coated

ZG*	Workpiece material		Strength/hardness [N/mm ²] [HRC]	Application data for ϕ [mm]						
				< 5			5-6.2			
				v_c	f	a	v_c	f	a	
P	P4	P4.1	Stainless steels, ferritic and martensitic	40	0.10	0.05	40	0.15	0.10	
	P6	P6.1	Stainless cast steels, ferritic and martensitic	40	0.10	0.05	40	0.15	0.10	
M	M1	M1.1	Stainless steels, austenitic	< 700 N/mm ²	40	0.10	0.05	40	0.15	0.10
		M1.2	Stainless steels, ferritic/austenitic (Duplex)	< 1000 N/mm ²	30	0.10	0.05	30	0.15	0.10
	M2	M2.1	Stainless cast steel, austenitic	< 700 N/mm ²	40	0.10	0.05	40	0.15	0.10
	M3	M3.1	Stainless cast steel, ferritic/austenitic (Duplex)	< 1000 N/mm ²	30	0.10	0.05	30	0.15	0.10

HNC-TI | B043272

Cutting material: Solid carbide, BTI-coated

HNC-TI | B043273

Cutting material: Solid carbide, BTI-coated

ZG*	Workpiece material		Strength/hardness [N/mm ²] [HRC]	Application data for ϕ [mm]						
				< 5			5-6.2			
				v_c	f	a	v_c	f	a	
S	S1	S1.1	Titanium, titanium alloys	< 400 N/mm ²	15	0.08	0.05	15	0.12	0.05
		S2.1	Titanium, titanium alloys	< 1200 N/mm ²	15	0.08	0.05	15	0.12	0.05
	S2	S2.2	Titanium, titanium alloys	> 1200 N/mm ²	15	0.08	0.05	15	0.12	0.05
		S3.1	Nickel, unalloyed and alloyed	< 900 N/mm ²	15	0.08	0.05	15	0.12	0.05
	S3	S3.2	Nickel, unalloyed and alloyed	> 900 N/mm ²	15	0.08	0.05	15	0.12	0.05
		S4	S4.1	High-temperature super alloy, Ni-, Co-, and Fe-based		15	0.08	0.05	15	0.12
	S5	S5.1	Molybdenum and tungsten alloys		15	0.08	0.05	15	0.12	0.05

HNC-AL | B043250

Cutting material: Solid carbide, BAL-coated

HNC-AL | B043251

Cutting material: Solid carbide, BAL-coated

ZG*	Workpiece material		Strength/hardness [N/mm ²] [HRC]	Application data for ϕ [mm]						
				< 5			5-6.2			
				v_c	f	a	v_c	f	a	
N	N1	N1.1	Aluminium, unalloyed and alloyed < 3% Si		250	0.50	0.10	250	0.60	0.10
		N1.2	Aluminium, alloyed \leq 7% Si		250	0.50	0.10	250	0.60	0.10
		N1.3	Aluminium, alloyed > 7-12% Si		250	0.50	0.10	250	0.60	0.10
		N1.4	Aluminium, alloyed > 12% Si		250	0.50	0.10	250	0.60	0.10

PcBN reamers | B040356

PcBN reamers | B040366

ZG*	Workpiece material		Strength/hardness [N/mm ²] [HRC]	
K	K1	K1.1	Cast iron with lamellar graphite (grey cast iron), GJL	< 300 N/mm ²
H	H1	H1.1	Hardened steel/cast steel	45-55 HRC
		H1.2	Hardened steel/cast steel	55-64 HRC

Application data for ϕ [mm]												
> 6.2-8			> 8-12			> 12-16.2			> 16.2-20.2			
v_c	f	a	v_c	f	a	v_c	f	a	v_c	f	a	
40	0.30	0.10	40	0.40	0.10	40	0.50	0.20	40	0.60	0.20	
40	0.30	0.10	40	0.40	0.10	40	0.50	0.20	40	0.60	0.20	
40	0.30	0.10	40	0.40	0.10	40	0.50	0.20	40	0.60	0.20	
30	0.30	0.10	30	0.40	0.10	30	0.50	0.20	30	0.60	0.20	
40	0.30	0.10	40	0.40	0.10	40	0.50	0.20	40	0.60	0.20	
30	0.30	0.10	30	0.40	0.10	30	0.50	0.20	30	0.60	0.20	

Application data for ϕ [mm]												
> 6.2-8			> 8-12			> 12-16.2			> 16.2-20.2			
v_c	f	a	v_c	f	a	v_c	f	a	v_c	f	a	
15	0.15	0.10	15	0.15	0.10	15	0.20	0.15	15	0.25	0.20	
15	0.15	0.10	15	0.15	0.10	15	0.20	0.15	15	0.25	0.20	
15	0.15	0.10	15	0.15	0.10	15	0.20	0.15	15	0.25	0.20	
15	0.15	0.10	15	0.15	0.10	15	0.20	0.15	15	0.25	0.20	
15	0.15	0.10	15	0.15	0.10	15	0.20	0.15	15	0.25	0.20	
15	0.15	0.10	15	0.15	0.10	15	0.20	0.15	15	0.25	0.20	
15	0.15	0.10	15	0.15	0.10	15	0.20	0.15	15	0.25	0.20	

Application data for ϕ [mm]												
> 6.2-8			> 8-12			12-16.2			> 16.2-20			
v_c	f	a	v_c	f	a	v_c	f	a	v_c	f	a	
250	0.80	0.10	250	1.30	0.20	250	1.50	0.30	250	1.80	0.30	
250	0.80	0.10	250	1.30	0.20	250	1.50	0.30	250	1.80	0.30	
250	0.80	0.10	250	1.30	0.20	250	1.50	0.30	250	1.80	0.30	
250	0.80	0.10	250	1.30	0.20	250	1.50	0.30	250	1.80	0.30	

Application data for ϕ [mm]												
3-3.7			> 3.7-5.7			> 5.7-7.2			> 7.2-10.2			
v_c	f	a	v_c	f	a	v_c	f	a	v_c	f	a	
200	0.16	0.10	200	0.24	0.20	200	0.50	0.20	200	0.80	0.20	
80	0.10	0.10	80	0.22	0.10	80	0.22	0.10	80	0.30	0.10	
80	0.08	0.10	80	0.15	0.10	80	0.15	0.10	80	0.25	0.10	

The specified cutting data are guide values.

The optimum data for the respective machining task should be determined during the test or machining.

Cutting data recommendations for HNC reamers

Feed f [mm/U], cutting speed v_c [m/min] and stock removal a [mm]

HNC-HT | B043280

Cutting material: Solid carbide, BHV-coated

HNC-HT | B043281

Cutting material: Solid carbide, BHV-coated

	ZG*	Workpiece material	Strength/hardness [N/mm ²] [HRC]	Application data for ϕ [mm]					
				< 5			5-6.2		
				v_c	f	a	v_c	f	a
H	H1.1	Hardened steel/cast steel	45-55 HRC	10	0.06	0.05	10	0.10	0.05
	H1.2	Hardened steel/cast steel	55-64 HRC	10	0.06	0.05	10	0.10	0.05
	H2	Wear-resistant cast / chill casting, GJN		10	0.06	0.05	10	0.10	0.05

HNC-Diamond | B043290

Cutting material: Solid carbide, diamond-coated

HNC-Diamond | B043291

Cutting material: Solid carbide, diamond-coated

	ZG*	Workpiece material	Application data for ϕ [mm]					
			< 5			5-6.2		
			v_c	f	a	v_c	f	a
C	C1.1	Plastic range, reinforced with aramid fibre (AFK)	50	0.25	0.20	50	0.25	0.20
	C1.2	Plastic range (duroplastic), CFK/GFK	50	0.25	0.20	50	0.25	0.20
	C1.3	Plastic range (thermoplastic), CFK/GFK	50	0.25	0.20	50	0.25	0.20

HNC-Short | B043265

Cutting material: Solid carbide, BSP-coated

	ZG*	Workpiece material	Strength/hardness [N/mm ²] [HRC]	Application data for ϕ [mm]						
				< 5			5-6.1			
				v_c	f	a	v_c	f	a	
P	P1	P1.1	Structural, machining, case hardened and tempering steels, unalloyed	< 700 N/mm ²	180	0.20	0.10	180	0.30	0.10
		P1.2	Structural, machining, case hardened and tempering steels, unalloyed	< 1200 N/mm ²	140	0.20	0.10	140	0.30	0.10
	P2	P2.1	Nitriding, hardening and tempering steels, alloyed	< 900 N/mm ²	180	0.20	0.10	180	0.30	0.10
		P2.2	Nitriding, hardening and tempering steels, alloyed	< 1400 N/mm ²	140	0.20	0.10	140	0.30	0.10
	P3	P3.1	Tool steels, roller bearing steels, spring steels and high-speed steels	< 900 N/mm ²	180	0.20	0.10	180	0.30	0.10
		P3.2	Tool steels, roller bearing steels, spring steels and high-speed steels	< 1500 N/mm ²	140	0.20	0.10	140	0.30	0.10
P5	P5.1	Cast steel		140	0.20	0.10	140	0.30	0.10	
K	K1	K1.1	Cast iron with lamellar graphite (grey cast iron), GJL	< 300 N/mm ²	110	0.30	0.10	110	0.40	0.10
		K2.1	Cast iron with spheroidal graphite, GJS	< 500 N/mm ²	150	0.30	0.10	150	0.40	0.10
	K2	K2.2	Cast iron with spheroidal graphite, GJS	500-800 N/mm ²	90	0.30	0.10	90	0.40	0.10
		K2.3	Cast iron with spheroidal graphite, GJS	> 800 N/mm ²	90	0.30	0.10	90	0.40	0.10
	K3	K3.1	Cast iron with vermicular graphite, GJV; malleable cast iron, GJM	< 500 N/mm ²	90	0.30	0.10	90	0.40	0.10
		K3.2	Cast iron with vermicular graphite, GJV; malleable cast iron, GJM	> 500 N/mm ²	90	0.30	0.10	90	0.40	0.10

Application data for \varnothing [mm]															
> 6.2-8			> 8-12			> 12-16			> 16-16.2			> 16.2-20.2			
v_c	f	a	v_c	f	a	v_c	f	a	v_c	f	a	v_c	f	a	
10	0.12	0.05	10	0.12	0.10	10	0.18	0.10	10	0.18	0.20	10	0.18	0.20	
10	0.12	0.05	10	0.12	0.10	10	0.18	0.10	10	0.18	0.20	10	0.18	0.20	
10	0.12	0.05	10	0.12	0.10	10	0.18	0.10	10	0.18	0.20	10	0.18	0.20	

Application data for \varnothing [mm]													
> 6.2-8			> 8-12			> 12-16.2			> 16.2-20.2				
v_c	f	a	v_c	f	a	v_c	f	a	v_c	f	a		
50	0.40	0.20	50	0.40	0.20	50	0.40	0.20	50	0.40	0.20		
50	0.40	0.20	50	0.40	0.20	50	0.40	0.20	50	0.40	0.20		
50	0.40	0.20	50	0.40	0.20	50	0.40	0.20	50	0.40	0.20		

Application data for \varnothing [mm]															
> 6.1-8			> 8-12			> 12-15.1			> 15.1-16			> 16-20.1			
v_c	f	a	v_c	f	a	v_c	f	a	v_c	f	a	v_c	f	a	
180	0.50	0.10	180	0.80	0.15	180	1.10	0.20	180	1.50	0.20	180	1.50	0.20	
140	0.50	0.10	140	0.80	0.15	140	1.10	0.20	140	1.50	0.20	140	1.50	0.20	
180	0.50	0.10	180	0.80	0.15	180	1.10	0.20	180	1.50	0.20	180	1.50	0.20	
140	0.50	0.10	140	0.80	0.15	140	1.10	0.20	140	1.50	0.20	140	1.50	0.20	
180	0.50	0.10	180	0.80	0.15	180	1.10	0.20	180	1.50	0.20	180	1.50	0.20	
140	0.50	0.10	140	0.80	0.15	140	1.10	0.20	140	1.50	0.20	140	1.50	0.20	
140	0.50	0.10	140	0.80	0.15	140	1.10	0.20	140	1.50	0.20	140	1.50	0.20	
110	0.60	0.10	110	1.00	0.20	110	1.30	0.20	110	1.80	0.30	110	1.80	0.30	
150	0.60	0.15	150	1.00	0.20	150	1.30	0.20	150	1.80	0.30	150	1.80	0.30	
90	0.60	0.15	90	1.00	0.20	90	1.30	0.20	90	1.80	0.30	90	1.80	0.30	
90	0.60	0.15	90	1.00	0.20	90	1.30	0.20	90	1.80	0.30	90	1.80	0.30	
90	0.60	0.15	90	1.00	0.20	90	1.30	0.20	90	1.80	0.30	90	1.80	0.30	
90	0.60	0.15	90	1.00	0.20	90	1.30	0.20	90	1.80	0.30	90	1.80	0.30	

The specified cutting data are guide values.
The optimum data for the respective machining task should be determined during the test or machining.

Cutting data recommendations for FixReam 700

Feed and cutting speed

B042200 | B042700 | B042201 | B042701

ZG*		Workpiece material	Strength/hardness [N/mm ²] [HRC]
P	P1	P1.1 Structural, machining, case hardened and tempering steels, unalloyed	< 700
		P1.2 Structural, machining, case hardened and tempering steels, unalloyed	< 1,200
	P2	P2.1 Nitriding, hardening and tempering steels, alloyed	< 900
		P2.2 Nitriding, hardening and tempering steels, alloyed	< 1,400
	P3	P3.1 Tool, bearing, spring and high-speed steels**	< 800
		P3.2 Tool, bearing, spring and high-speed steels**	< 1,000
		P3.3 Tool, bearing, spring and high-speed steels**	< 1,500
	K	K1.1 Cast iron with lamellar graphite (grey cast iron), GJL	< 300
		K2.1 Cast iron with spheroidal graphite, GJS	< 500

* BECK machining groups

** If the alloy parts Cr, Mo, Ni, V, W in total > 8%, then select the next highest BECK machining group.

	Cutting speed v_c [m/min]	Feed f_z [mm] for tool diameter
	Internal cooling	z 6 9.900 - 32.200
	120	0.150
	120	0.150
	110	0.150
	110	0.120
	110	0.150
	120	0.150
	120	
	120	0.200
	120	0.180

The specified cutting data are guide values.

The optimum data for the respective machining task should be determined during the test or machining.

Cutting data recommendations for drill reamer

Feed and cutting speed

Drill-Reamer-Pyramid | B093505

Drill-Reamer | B093305, B093303, B093301

ZG*	Workpiece material		Strength/hardness [N/mm ²] [HRC]	
P	P1	P1.1 Structural, machining, case hardened and tempering steels, unalloyed	< 700	
		P1.2 Structural, machining, case hardened and tempering steels, unalloyed	< 1,200	
	P2	P2.1 Nitriding, hardening and tempering steels, alloyed	< 900	
		P2.2 Nitriding, hardening and tempering steels, alloyed	< 1,400	
	P3	P3.1 Tool, bearing, spring and high-speed steels**	< 800	
		P3.2 Tool, bearing, spring and high-speed steels**	< 1,000	
		P3.3 Tool, bearing, spring and high-speed steels**	< 1,500	
	P5	P5.1 Cast steel		
	K	K1	K1.1 Cast iron with lamellar graphite (grey cast iron), GJL	< 300
			K2.1 Cast iron with spheroidal graphite, GJS	< 500
K2		K2.2 Cast iron with spheroidal graphite, GJS	≤ 800	
		K3.1 Cast iron with vermicular graphite, GJV; malleable cast iron, GJM	< 500	
K3		K3.2 Cast iron with vermicular graphite, GJV; malleable cast iron, GJM	> 500	

* BECK machining groups

** If the alloy parts Cr, Mo, Ni, V, W in total > 8%, then select the next highest BECK machining group.

	vc [m/min]		Feed f_z [mm] for tool diameter					
	Internal cooling	External cooling	4.00	6.00	8.00	10.00	12.00	16.00
	90	70	0.10	0.12	0.15	0.18	0.22	0.24
	80	60	0.12	0.15	0.19	0.23	0.27	0.30
	90	70	0.11	0.14	0.18	0.22	0.26	0.29
	65	50	0.10	0.12	0.15	0.17	0.20	0.23
	70	50	0.10	0.13	0.16	0.20	0.23	0.26
	55	45	0.09	0.11	0.13	0.16	0.19	0.21
	55	35	0.07	0.09	0.11	0.13	0.15	0.16
	90	70	0.11	0.14	0.18	0.22	0.26	0.29
	110	70	0.14	0.18	0.24	0.30	0.35	0.40
	145	80	0.14	0.18	0.23	0.28	0.33	0.37
	90	60	0.12	0.16	0.20	0.24	0.28	0.32
	80	65	0.13	0.17	0.21	0.26	0.30	0.34
	70	55	0.11	0.14	0.17	0.21	0.24	0.27

The specified cutting data are guide values.

The optimum data for the respective machining task should be determined during the test or machining.

Cutting data recommendations for XR replaceable head reamers

Feed f [mm/U], cutting speed v_c [m/min] and stock removal a [mm]

XR 06 | B081631

Cutting material: Solid carbide, BSP-coated

XR 06 | B081661

Cutting material: Solid carbide, BSP-coated

XR 01 | B081618

Cutting material: Carbide, BSP-coated

XR 01 | B081651

Cutting material: Carbide, BSP-coated

ZG*	Workpiece material		Strength/hardness [N/mm ²] [HRC]
P	P1	P1.1 Structural, machining, case hardened and tempering steels, unalloyed	< 700 N/mm ²
		P1.2 Structural, machining, case hardened and tempering steels, unalloyed	< 1200 N/mm ²
	P2	P2.1 Nitriding, hardening and tempering steels, alloyed	< 900 N/mm ²
		P2.2 Nitriding, hardening and tempering steels, alloyed	< 1400 N/mm ²
	P3	P3.1 Tool steels, roller bearing steels, spring steels and high-speed steels	< 900 N/mm ²
		P3.2 Tool steels, roller bearing steels, spring steels and high-speed steels	< 1500 N/mm ²
P5	P5.1 Cast steel		
K	K1	K1.1 Cast iron with lamellar graphite (grey cast iron), GJL	< 300 N/mm ²
		K2.1 Cast iron with spheroidal graphite, GJS	< 500 N/mm ²
	K2	K2.2 Cast iron with spheroidal graphite, GJS	500-800 N/mm ²
		K2.3 Cast iron with spheroidal graphite, GJS	> 800 N/mm ²
	K3	K3.1 Cast iron with vermicular graphite, GJV; malleable cast iron, GJM	< 500 N/mm ²
		K3.2 Cast iron with vermicular graphite, GJV; malleable cast iron, GJM	> 500 N/mm ²

XR 06 | B081632

Cutting material: Solid carbide, BVA-coated

XR 06 | B081662

Cutting material: Solid carbide, BVA-coated

ZG*	Workpiece material		Strength/hardness [N/mm ²] [HRC]
P	P4	P4.1 Stainless steels, ferritic and martensitic	
	P6	P6.1 Stainless cast steels, ferritic and martensitic	
M	M1	M1.1 Stainless steels, austenitic	< 700 N/mm ²
		M1.2 Stainless steels, ferritic/austenitic (Duplex)	< 1000 N/mm ²
	M2	M2.1 Stainless cast steel, austenitic	< 700 N/mm ²
	M2	M3.1 Stainless cast steel, ferritic/austenitic (Duplex)	< 1000 N/mm ²

XR 06 | B081639

Cutting material: Solid carbide, CVD-coated

XR 06 | B081669

Cutting material: Solid carbide, CVD-coated

ZG*	Workpiece material		Strength/hardness [N/mm ²] [HRC]
K	K1	K1.1 Cast iron with lamellar graphite (grey cast iron), GJL	< 300 N/mm ²
		K2.1 Cast iron with spheroidal graphite, GJS	< 500 N/mm ²
	K2	K2.2 Cast iron with spheroidal graphite, GJS	500-800 N/mm ²
		K2.3 Cast iron with spheroidal graphite, GJS	> 800 N/mm ²
	K3	K3.1 Cast iron with vermicular graphite, GJV; malleable cast iron, GJM	< 500 N/mm ²
		K3.2 Cast iron with vermicular graphite, GJV; malleable cast iron, GJM	> 500 N/mm ²

Application data for \varnothing [mm]												
8-12			12-16			16-30			30-40			
v_c	f	a	v_c	f	a	v_c	f	a	v_c	f	a	
160	0,70	0,10	160	1,00	0,20	160	1,50	0,20	160	2,00	0,30	
160	0,70	0,10	160	1,00	0,20	160	1,50	0,20	160	2,00	0,30	
160	0,70	0,10	160	1,00	0,20	160	1,50	0,20	160	2,00	0,30	
160	0,70	0,10	160	1,00	0,20	160	1,50	0,20	160	2,00	0,30	
160	0,70	0,10	160	1,00	0,20	160	1,50	0,20	160	2,00	0,30	
160	0,70	0,10	160	1,00	0,20	160	1,50	0,20	160	2,00	0,30	
80	0,50	0,10	80	0,80	0,20	80	1,50	0,20	80	1,50	0,30	
120	0,60	0,10	120	0,60	0,20	120	1,20	0,20	120	1,60	0,30	
120	0,60	0,10	120	0,60	0,20	120	1,20	0,20	120	1,60	0,30	
100	0,40	0,10	100	0,60	0,20	100	1,20	0,20	100	1,60	0,30	
100	0,40	0,10	100	0,60	0,20	100	1,20	0,20	100	1,60	0,30	
100	0,40	0,10	100	0,60	0,20	100	1,20	0,20	100	1,60	0,30	
100	0,40	0,10	100	0,60	0,20	100	1,20	0,20	100	1,60	0,30	

Application data for \varnothing [mm]												
8-9.7			9.7-16			16-30			30-40			
v_c	f	a	v_c	f	a	v_c	f	a	v_c	f	a	
40	0.30	0.10	40	0.40	0.20	40	0.50	0.20	40	1.20	0.30	
40	0.30	0.10	40	0.40	0.20	40	0.50	0.20	40	1.20	0.30	
40	0.30	0.10	40	0.40	0.20	40	0.50	0.20	40	1.20	0.30	
30	0.30	0.10	30	0.40	0.20	30	0.50	0.20	30	1.20	0.30	
40	0.30	0.10	40	0.40	0.20	40	0.50	0.20	40	1.20	0.30	
30	0.30	0.10	30	0.40	0.20	30	0.50	0.20	30	1.20	0.30	

Application data for \varnothing [mm]												
8 - 12			12 - 16			16 - 30			30 - 40			
v_c	f	a	v_c	f	a	v_c	f	a	v_c	f	a	
120	0.60	0.10	120	0.60	0.20	120	1.20	0.20	120	1.60	0.30	
120	0.60	0.10	120	0.60	0.20	120	1.20	0.20	120	1.60	0.30	
100	0.40	0.10	100	0.60	0.20	100	1.20	0.20	100	1.60	0.30	
100	0.40	0.10	100	0.60	0.20	100	1.20	0.20	100	1.60	0.30	
100	0.40	0.10	100	0.60	0.20	100	1.20	0.20	100	1.60	0.30	
100	0.40	0.10	100	0.60	0.20	100	1.20	0.20	100	1.60	0.30	

The specified cutting data are guide values.

The optimum data for the respective machining task should be determined during the test or machining.

Cutting data recommendations for XR replaceable head reamers

Feed f [mm/U], cutting speed vc [m/min] and stock removal a [mm]

XR 06 | B081634

Cutting material: Solid carbide, BAL-coated

XR 06 | B081664

Cutting material: Solid carbide, BAL-coated

ZG*	Workpiece material		Strength/hardness [N/mm ²] [HRC]
N N1	N1.1	Aluminium, unalloyed and alloyed < 3% Si	
	N1.2	Aluminium, alloyed ≤ 7% Si	
	N1.3	Aluminium, alloyed > 7-12% Si	
	N1.4	Aluminium, alloyed > 12% Si	

XR 06 | B081633

Cutting material: Solid carbide, BTI-coated

XR 06 | B081663

Cutting material: Solid carbide, BTI-coated

ZG*	Workpiece material		Strength/hardness [N/mm ²] [HRC]
S S1 S2 S3 S4 S5	S1.1	Titanium, titanium alloys	< 400 N/mm ²
	S2.1	Titanium, titanium alloys	< 1200 N/mm ²
	S2.2	Titanium, titanium alloys	> 1200 N/mm ²
	S3.1	Nickel, unalloyed and alloyed	< 900 N/mm ²
	S3.2	Nickel, unalloyed and alloyed	> 900 N/mm ²
	S4.1	High-temperature super alloy, Ni-, Co-, and Fe-based	
	S5.1	Molybdenum and tungsten alloys	

XR 01 | B081605

Cutting material: PCD

XR 01 | B081655

Cutting material: PCD

ZG*	Workpiece material		Strength/hardness [N/mm ²] [HRC]
N N1	N1.1	Aluminium, unalloyed and alloyed < 3% Si	
	N1.2	Aluminium, alloyed ≤ 7% Si	
	N1.3	Aluminium, alloyed > 7-12% Si	
	N1.4	Aluminium, alloyed > 12% Si	

Application data for \varnothing [mm]												
8-12			12-16			16-30			30-40			
v_c	f	a	v_c	f	a	v_c	f	a	v_c	f	a	
250	1.30	0.20	250	1.50	0.30	250	1.80	0.30	250	1.80	0.30	
250	1.30	0.20	250	1.50	0.30	250	1.80	0.30	250	1.80	0.30	
250	1.30	0.20	250	1.50	0.30	250	1.80	0.30	250	1.80	0.30	
250	1.30	0.20	250	1.50	0.30	250	1.80	0.30	250	1.80	0.30	

Application data for \varnothing [mm]												
8-12			12-16			16-30			30-40			
v_c	f	a	v_c	f	a	v_c	f	a	v_c	f	a	
15	0.15	0.10	15	0.20	0.15	15	0.25	0.20	15	0.25	0.20	
15	0.15	0.10	15	0.20	0.15	15	0.25	0.20	15	0.25	0.20	
15	0.15	0.10	15	0.20	0.15	15	0.25	0.20	15	0.25	0.20	
15	0.15	0.10	15	0.20	0.15	15	0.25	0.20	15	0.25	0.20	
15	0.15	0.10	15	0.20	0.15	15	0.25	0.20	15	0.25	0.20	
15	0.15	0.10	15	0.20	0.15	15	0.25	0.20	15	0.25	0.20	
15	0.15	0.10	15	0.20	0.15	15	0.25	0.20	15	0.25	0.20	

Application data for \varnothing [mm]									
8-14.59			14.6-29.99			30-40.2			
v_c	f	a	v_c	f	a	v_c	f	a	
200	0.60	0.10	200	1.50	0.15	200	2.00	0.15	
200	0.60	0.10	200	1.50	0.15	200	2.00	0.15	
200	0.60	0.10	200	1.50	0.15	200	2.00	0.15	
200	0.60	0.10	200	1.50	0.15	200	2.00	0.15	

The specified cutting data are guide values.

The optimum data for the respective machining task should be determined during the test or machining.

Cutting data recommendations for XR replaceable head reamers

Feed f [mm/U], cutting speed v_c [m/min] and stock removal a [mm]

XR 01 | B081610

Cutting material: Carbide, uncoated

XR 01 | B081650

Cutting material: Carbide, uncoated

ZG*	Workpiece material		Strength/hardness [N/mm ²] [HRC]
N	N1	N1.1 Aluminium, unalloyed and alloyed < 3% Si	
		N1.2 Aluminium, alloyed \leq 7% Si	
		N1.3 Aluminium, alloyed > 7-12% Si	
		N1.4 Aluminium, alloyed > 12% Si	
	N2	N2.1 Copper, unalloyed and low alloyed	< 300 N/mm ²
		N2.2 Copper, alloyed	> 300 N/mm ²
		N2.3 Brass, bronze, gunmetal	< 1200 N/mm ²

XR 01 | B081612

Cutting material: Cermet, uncoated

XR 01 | B081652

Cutting material: Cermet, uncoated

ZG*	Workpiece material		Strength/hardness [N/mm ²] [HRC]
P	P1	P1.1 Structural, machining, case hardened and tempering steels, unalloyed	< 700 N/mm ²
		P1.2 Structural, machining, case hardened and tempering steels, unalloyed	< 1200 N/mm ²
	P2	P2.1 Nitriding, hardening and tempering steels, alloyed	< 900 N/mm ²
		P2.2 Nitriding, hardening and tempering steels, alloyed	< 1400 N/mm ²
	P3	P3.1 Tool steels, roller bearing steels, spring steels and high-speed steels	< 900 N/mm ²
		P3.2 Tool steels, roller bearing steels, spring steels and high-speed steels	< 1500 N/mm ²
	P5	P5.1 Cast steel	
K	K2	K2.1 Cast iron with spheroidal graphite, GJS	< 500 N/mm ²
		K2.2 Cast iron with spheroidal graphite, GJS	500-800 N/mm ²
		K2.3 Cast iron with spheroidal graphite, GJS	> 800 N/mm ²
	K3	K3.1 Cast iron with vermicular graphite, GJV; malleable cast iron, GJM	< 500 N/mm ²
		K3.2 Cast iron with vermicular graphite, GJV; malleable cast iron, GJM	> 500 N/mm ²

XR 01 | B081611

Cutting material: Carbide, BVA-coated

XR 01 | B081659

Cutting material: Carbide, BVA-coated

ZG*	Workpiece material		Strength/hardness [N/mm ²] [HRC]
P	P4	P4.1 Stainless steels, ferritic and martensitic	
	P6	P6.1 Stainless cast steels, ferritic and martensitic	
M	M1	M1.1 Stainless steels, austenitic	< 700 N/mm ²
		M1.2 Stainless steels, ferritic/austenitic (Duplex)	< 1000 N/mm ²
	M2	M2.1 Stainless cast steel, austenitic	< 700 N/mm ²
	M2	M3.1 Stainless cast steel, ferritic/austenitic (Duplex)	< 1000 N/mm ²

Application data for ϕ [mm]												
8-12			12-16			16-30			30-40.2			
v_c	f	a	v_c	f	a	v_c	f	a	v_c	f	a	
30	0,30	0,20	30	0,40	0,30	30	0,50	0,30	30	0,60	0,30	
30	0,30	0,20	30	0,40	0,30	30	0,50	0,30	30	0,60	0,30	
30	0,30	0,20	30	0,40	0,30	30	0,50	0,30	30	0,60	0,30	
30	0,30	0,20	30	0,40	0,30	30	0,50	0,30	30	0,60	0,30	
30	0,30	0,20	30	0,40	0,30	30	0,50	0,30	30	0,60	0,30	
30	0,30	0,20	30	0,40	0,30	30	0,50	0,30	30	0,60	0,30	
30	0,30	0,20	30	0,40	0,30	30	0,50	0,30	30	0,60	0,30	

Application data for ϕ [mm]												
8-9.7			9.7-16			16-30			30-40			
v_c	f	a	v_c	f	a	v_c	f	a	v_c	f	a	
140	0.60	0.20	140	0.80	0.20	140	1.00	0.20	140	1.40	0.30	
90	0.60	0.20	90	0.80	0.20	90	1.00	0.20	90	1.40	0.30	
140	0.60	0.20	140	0.80	0.20	140	1.00	0.20	140	1.40	0.30	
90	0.60	0.20	90	0.80	0.20	90	1.00	0.20	90	1.40	0.30	
120	0.60	0.20	120	0.80	0.20	120	1.00	0.20	120	1.40	0.30	
90	0.60	0.20	90	0.80	0.20	90	1.00	0.20	90	1.40	0.30	
90	0.60	0.20	90	0.80	0.20	90	1.00	0.20	90	1.40	0.30	
120	0.70	0.20	120	1.20	0.20	120	1.60	0.20	120	2.00	0.30	
90	0.70	0.20	90	1.20	0.20	90	1.60	0.20	90	2.00	0.30	
90	0.70	0.20	90	1.20	0.20	90	1.60	0.20	90	2.00	0.30	
90	0.70	0.20	90	1.20	0.20	90	1.60	0.20	90	2.00	0.30	
90	0.70	0.20	90	1.20	0.20	90	1.60	0.20	90	2.00	0.30	

Application data for ϕ [mm]												
8-9.7			9.7-16			16-30			30-40			
v_c	f	a	v_c	f	a	v_c	f	a	v_c	f	a	
40	0.30	0.10	40	0.40	0.20	40	0.50	0.20	40	1.20	0.30	
40	0.30	0.10	40	0.40	0.20	40	0.50	0.20	40	1.20	0.30	
40	0.30	0.10	40	0.40	0.20	40	0.50	0.20	40	1.20	0.30	
30	0.30	0.10	30	0.40	0.20	30	0.50	0.20	30	1.20	0.30	
40	0.30	0.10	40	0.40	0.20	40	0.50	0.20	40	1.20	0.30	
30	0.30	0.10	30	0.40	0.20	30	0.50	0.20	30	1.20	0.30	

The specified cutting data are guide values.

The optimum data for the respective machining task should be determined during the test or machining.





MACHINE AND MANUAL REAMERS

Introduction

Product overview	140
Machine reamers without internal cooling	142
Hand reamers	220
Shell reamers	232

Technical appendix

Cutting data recommendations	238
------------------------------------	-----

PRODUCT OVERVIEW

Machine and manual reamers

With small to medium lot sizes or when machining on older machines without internal coolant supply, the advantages of the high cutting data of the high-performance reamers cannot be utilised. The more affordable DIN reamers are more of a cost-effective solution here.

BECK machine reamers are available as carbide and HSS variants. High availability from stock and the consistently high quality of the raw materials used are of course features of this product segment from BECK.

BECK machine reamers are available from stock in diameters up to 50 mm (depending on the type of tool). BECK miniature reamers are available from a diameter of 0.6 mm as a speciality. In addition, special machine expandable reamers, bridge reamers, helical reamers and machine end face reamers are available ex stock.

Thanks to their large adjustment range, quick adjustment reamers are particularly suitable for repair work.

HSS boring tools allow precise boring before reaming and avoid the need for expensive intermediate diameters thanks to their adaptable design.



Machine reamers



Machine reamers without internal cooling

BECK offers cost-effective DIN reamers in carbide and HSS variants with high stock availability and quality, particularly suitable for applications with small to medium lot sizes or older machines without internal coolant supply.

Ø area: 0.600 - 40.000*



Hand reamers

BECK manual and taper reamers are high-quality tools, adapted for hard-to-reach bores or tapered transitions, and offer high surface finish and performance despite manual use without internal cooling.

Ø area: 1.000 - 60.000*

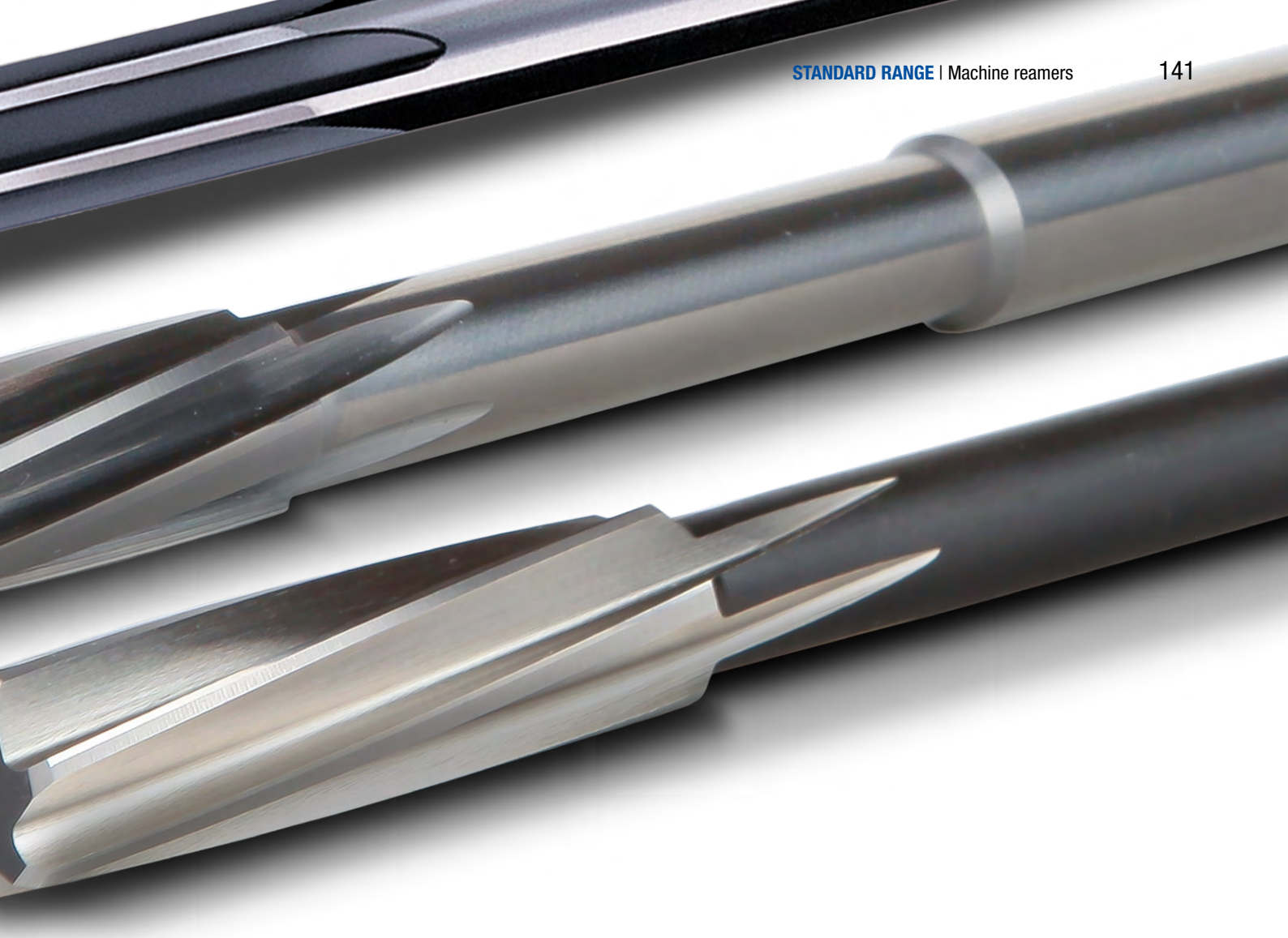

Manual reamers



Quick adjustment reamer

Features a wide adjustment range. Especially suitable for repair work.

Ø area: 6.400 - 95.000



Shell reamers

Shell reamers in accordance with DIN and associated tool holders in accordance with DIN.

Ø area: 25.000 - 100.000*

NC machine reamer | B040210

Fixed design with straight shank diameters suitable for connection in hydraulic chucks, high-accuracy chucks and shrink chucks*

Design:

Diameter: 0.950 - 20.000 mm
 Cutting direction: Right-hand cutting
 Cutting material: Carbide, uncoated (HU613)
 Groove direction: Straight fluted
 Geometry: EU spacing (from \varnothing 3 mm)

Special feature:

\varnothing 1 to 3.5 mm: Solid carbide design with centre points on both sides.
 \varnothing 4 to 13 mm: Solid carbide design with internal centre.
 \varnothing 14 to 20 mm: Design with brazed carbide indexable blades and steel shank.

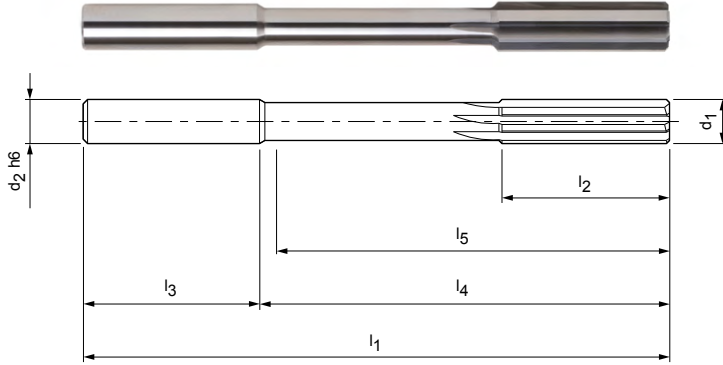

Preferred series in H7

Dimensions							z	Order no.
d_1 H7	d_2 h6	l_1	l_2	l_3	l_4	l_5		
1,000	3	50	6	28	22	17,5	3	30670539
1,100	3	50	9	28	22	17,5	3	30670540
1,200	3	50	9	28	22	17,5	3	30670541
1,500	3	50	9	28	22	18	3	30670543
1,600	3	50	10	28	22	18	3	30670544
1,800	3	50	11	28	22	18,5	4	30670545
2,000	3	50	12	28	22	18,5	4	30670546
2,200	3	50	12	28	22	18,5	4	30670547
2,500	3	60	16	28	32	29	4	30670548
3,000	4	65	17	28	37	33	6	30670549
3,200	4	65	18	28	37	33	6	30670550
3,500	4	75	18	28	47	43	6	30670551
4,000	4	75	19	28	47	43	6	30612427
4,500	6	80	21	36	44	39	6	30612428
5,000	6	93	23	36	57	52	6	30612429
5,500	6	93	26	36	57	53	6	30612430
6,000	6	93	26	36	57	53	6	30612431
6,500	6	101	28	36	65	61	6	30612432
7,000	8	109	31	36	73	68	6	30612433
7,500	8	109	31	36	73	68	6	30612434
8,000	8	117	33	36	81	77	6	30612435
8,500	8	117	33	36	81	77	6	30612436
9,000	10	125	36	40	85	80	6	30612437
9,500	10	125	36	40	85	80	6	30612438
10,000	10	133	38	40	93	88	6	30612439
10,500	10	133	38	40	93	88	6	30612440
11,000	10	142	41	40	102	97	6	30612441
12,000	12	151	44	45	106	100	6	30612442
13,000	12	151	44	45	106	100	6	30612443
14,000	16	160	47	48	112	106	6	30612444
15,000	16	162	50	48	114	108	6	30612445
16,000	16	170	52	48	122	116	6	30612446
17,000	18	175	52	48	127	121	6	30612447
18,000	18	182	52	48	134	128	6	30612448
19,000	20	189	52	50	139	133	6	30612449
20,000	20	195	52	50	145	139	6	30612450

Configurable features



Bore diameter tolerance \geq IT6:
 - Diameter in increments of 0.001 mm freely selectable
 - Can be ordered in tolerance \geq IT6



Specification:
 B040210[Diameter][Tolerance]

G variant (see page 303):
 - Diameter in increments of 0.001 mm freely selectable
 - Can be ordered from tolerances $\geq 4 \mu\text{m}$

G variant specification:
 B040210[Diameter][Tolerance]

IT6 tolerance example:
 B040210-Ø16.350H6

Bore diameter $d_1 = 16.350 \text{ H6}$

G variant example:
 B040210-Ø16.350-4

Special tool diameter $d_1 = 16.350 -4 \mu\text{m}$

Dimensions of configurable series IT6

d_1	$d_2 \text{ h6}$	l_1	l_2	l_3	l_4	l_5	z
0,950-1,060 ⁽¹⁾	3	50	6	28	22	17,5	3
1,061-1,320 ⁽¹⁾	3	50	9	28	22	17,5	3
1,321-1,500 ⁽¹⁾	3	50	9	28	22	18	3
1,501-1,700 ⁽¹⁾	3	50	10	28	22	18	3
1,701-1,900 ⁽¹⁾	3	50	11	28	22	18,5	4
1,901-2,360 ⁽¹⁾	3	50	12	28	22	18,5	4
2,361-2,650 ⁽¹⁾	3	60	16	28	32	29	4
2,651-2,800 ⁽¹⁾	4	65	17	28	37	33	6
2,801-3,030 ⁽²⁾	4	65	17	28	37	33	6
3,031-3,350	4	65	18	28	37	33	6
3,351-3,750	4	75	18	28	47	43	6
3,751-4,250	4	75	19	28	47	43	6
4,251-4,750	6	80	21	36	44	39	6
4,751-5,300	6	93	23	36	57	52	6
5,301-6,030 ⁽²⁾	6	93	26	36	57	53	6
6,031-6,700	6	101	28	36	65	61	6
6,701-7,500	8	109	31	36	73	68	6
7,501-8,500	8	117	33	36	81	77	6
8,501-9,500	10	125	36	40	85	80	6
9,501-10,600	10	133	38	40	93	88	6
10,601-11,800	10	142	41	40	102	97	6
11,801-13,200	12	151	44	45	106	100	6
13,201-14,000	16	160	47	48	112	106	6
14,001-15,000	16	162	50	48	114	108	6
15,001-16,000	16	170	52	48	122	116	6
16,001-17,000	18	175	52	48	127	121	6
17,001-18,000	18	182	52	48	134	128	6
18,001-19,000	20	189	52	50	139	133	6
19,001-20,000	20	195	52	50	145	139	6

Only inductive shrink units are to be used for tools with brazed indexable blades.

(1) $\leq d_1$ 3.000 mm only IT7 possible.

(2) Minimal deviation from the standard for manufacturing reasons.

Dimensions in mm.

For cutting data recommendations, see end of chapter.

Special designs and possible coatings available upon request.

* Only inductive shrink units are to be used for tools with brazed indexable blades.

Micro-NC machine reamer I B040240*

Fixed design with straight shank diameters suitable for connection in hydraulic chucks, high-accuracy chucks and shrink chucks

Design:

Diameter:
Cutting direction:
Cutting material:
Groove direction:

0.600 - 0.900 mm
Right-hand cutting
Solid carbide, uncoated (HU613)
Spiral fluted

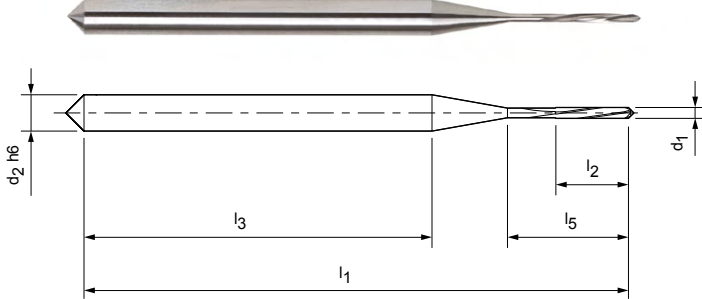

Preferred series available from stock in +0.004 mm

Dimensions						z	Order no.
$d_1 +0.004$	d_2 h6	l_1	l_2	l_3	l_5		
0,600	3	45	5	28	7,5	4	30274506
0,700	3	45	5	28	7,5	4	30274507
0,800	3	45	6	28	8	4	30274508
0,900	3	45	6	28	8	4	30274509

Dimensions in mm.

For cutting data recommendations, see end of chapter.

* Intermediate diameters and special tolerances available on demand. Minimum order quantity 10 units per dimension.

Special designs and possible coatings available upon request.

NC machine reamer I B040211*

Fixed design with straight shank diameters suitable for connection in hydraulic chucks, high-accuracy chucks and shrink chucks*

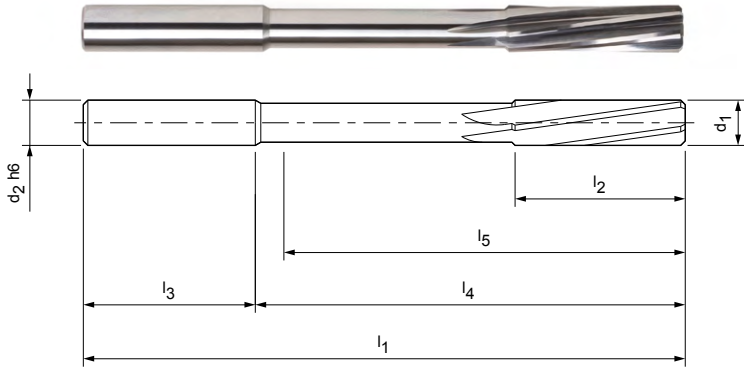

Design:

Diameter:	0.950 - 20.000 mm
Cutting direction:	Right-hand cutting
Cutting material:	Carbide, uncoated (HU613)
Groove direction:	Spiral fluted ($\varnothing \leq 13$ mm) Left-hand fluted ($\varnothing \geq 14$ mm)
Geometry:	EU spacing (from $\varnothing 3$ mm)

Special feature:

$\varnothing 0.98$ to 3.5 mm:	Solid carbide design with centre points on both sides.
$\varnothing 3.97$ to 13 mm:	Solid carbide design with internal centre.
$\varnothing 14$ to 20 mm:	Left-hand fluted design with brazed carbide indexable blades and steel shank.

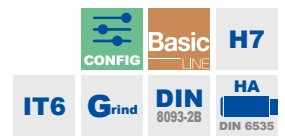

Preferred series available from stock in H7 | +0.004 mm

Dimensions								z	Order no.
d_1	Tolerance	$d_2\ h6$	l_1	l_2	l_3	l_4	l_5		
0,980	+0,004	3	50	6	28	22	17,5	3	30612451
0,990	+0,004	3	50	6	28	22	17,5	3	30612452
1,000	H7	3	50	6	28	22	17,5	3	30612453
1,010	+0,004	3	50	6	28	22	17,5	3	30612454
1,020	+0,004	3	50	6	28	22	17,5	3	30612455
1,030	+0,004	3	50	6	28	22	17,5	3	30612456
1,100	H7	3	50	9	28	22	17,5	3	30612457
1,200	H7	3	50	9	28	22	17,5	3	30612458
1,480	+0,004	3	50	9	28	22	18	3	30612459
1,490	+0,004	3	50	9	28	22	18	3	30612460
1,500	H7	3	50	9	28	22	18	3	30612461
1,510	+0,004	3	50	10	28	22	18	3	30612462
1,520	+0,004	3	50	10	28	22	18	3	30612463
1,530	+0,004	3	50	10	28	22	18	3	30612464
1,600	H7	3	50	10	28	22	18	3	30612465
1,800	H7	3	50	11	28	22	18,5	4	30612466
1,980	+0,004	3	50	12	28	22	18,5	4	30612467
1,990	+0,004	3	50	12	28	22	18,5	4	30612468
2,000	H7	3	50	12	28	22	18,5	4	30612469
2,010	+0,004	3	50	12	28	22	18,5	4	30612470
2,020	+0,004	3	50	12	28	22	18,5	4	30612471
2,030	+0,004	3	50	12	28	22	18,5	4	30612472
2,200	H7	3	50	12	28	22	18,5	4	30612473
2,480	+0,004	3	60	16	28	32	29	4	30612474
2,490	+0,004	3	60	16	28	32	29	4	30612475
2,500	H7	3	60	16	28	32	29	4	30612476
2,510	+0,004	3	60	16	28	32	29	4	30612477
2,520	+0,004	3	60	16	28	32	29	4	30612478
2,530	+0,004	3	60	16	28	32	29	4	30612479
2,970	+0,004	4	65	17	28	37	33	6	30612480
2,980	+0,004	4	65	17	28	37	33	6	30612481
2,990	+0,004	4	65	17	28	37	33	6	30612482
3,000	H7	4	65	17	28	37	33	6	30612483
3,010	+0,004	4	65	17	28	37	33	6	30612484
3,020	+0,004	4	65	17	28	37	33	6	30612485

NC machine reamer I B040211, fixed design according to DIN 8093-2B

Dimensions								z	Order no.
d ₁	Tolerance	d ₂ h6	l ₁	l ₂	l ₃	l ₄	l ₅		
3,030	+0,004	4	65	17	28	37	33	6	30612486
3,200	H7	4	65	18	28	37	33	6	30612487
3,500	H7	4	75	18	28	47	43	6	30612488
3,970	+0,004	4	75	19	28	47	43	6	30612489
3,980	+0,004	4	75	19	28	47	43	6	30612490
3,990	+0,004	4	75	19	28	47	43	6	30612491
4,000	H7	4	75	19	28	47	43	6	30612492
4,010	+0,004	4	75	19	28	47	43	6	30612493
4,020	+0,004	4	75	19	28	47	43	6	30612494
4,030	+0,004	4	75	19	28	47	43	6	30612495
4,500	H7	6	80	21	36	44	39	6	30612496
4,970	+0,004	6	93	23	36	57	52	6	30612497
4,980	+0,004	6	93	23	36	57	52	6	30612498
4,990	+0,004	6	93	23	36	57	52	6	30612499
5,000	H7	6	93	23	36	57	52	6	30612500
5,010	+0,004	6	93	23	36	57	52	6	30612501
5,020	+0,004	6	93	23	36	57	52	6	30612502
5,030	+0,004	6	93	23	36	57	52	6	30612503
5,500	H7	6	93	26	36	57	53	6	30612504
5,970	+0,004	6	93	26	36	57	53	6	30612505
5,980	+0,004	6	93	26	36	57	53	6	30612506
5,990	+0,004	6	93	26	36	57	53	6	30612507
6,000	H7	6	93	26	36	57	53	6	30612508
6,010	+0,004	6	93	26	36	57	53	6	30612509
6,020	+0,004	6	93	26	36	57	53	6	30612510
6,030	+0,004	6	93	26	36	57	53	6	30612511
6,500	H7	6	101	28	36	65	61	6	30612512
7,000	H7	8	109	31	36	73	68	6	30612513
7,500	H7	8	109	31	36	73	68	6	30612514
7,970	+0,004	8	117	33	36	81	77	6	30612515
7,980	+0,004	8	117	33	36	81	77	6	30612516
7,990	+0,004	8	117	33	36	81	77	6	30612517
8,000	H7	8	117	33	36	81	77	6	30612518
8,010	+0,004	8	117	33	36	81	77	6	30612519
8,020	+0,004	8	117	33	36	81	77	6	30612520
8,030	+0,004	8	117	33	36	81	77	6	30612521
8,040	+0,004	8	117	33	36	81	77	6	30612522
8,500	H7	8	117	33	36	81	77	6	30612523
9,000	H7	10	125	36	40	85	80	6	30612524
9,500	H7	10	125	36	40	85	80	6	30612525
9,970	+0,004	10	133	38	40	93	88	6	30612526
9,980	+0,004	10	133	38	40	93	88	6	30612527
9,990	+0,004	10	133	38	40	93	88	6	30612528
10,000	H7	10	133	38	40	93	88	6	30612529
10,010	+0,004	10	133	38	40	93	88	6	30612530
10,020	+0,004	10	133	38	40	93	88	6	30612531
10,030	+0,004	10	133	38	40	93	88	6	30612532
10,040	+0,004	10	133	38	40	93	88	6	30612533
10,050	+0,004	10	133	38	40	93	88	6	30612534
10,500	H7	10	133	38	40	93	88	6	30612535
11,000	H7	10	142	41	40	102	97	6	30612536
11,970	+0,004	12	151	44	45	106	100	6	30612537
11,980	+0,004	12	151	44	45	106	100	6	30612538
11,990	+0,004	12	151	44	45	106	100	6	30612539
12,000	H7	12	151	44	45	106	100	6	30612540
12,010	+0,004	12	151	44	45	106	100	6	30612541
12,020	+0,004	12	151	44	45	106	100	6	30612542

NC machine reamer I B040211, fixed design according to DIN 8093-2B

Dimensions								z	Order no.
d ₁	Tolerance	d ₂ h6	l ₁	l ₂	l ₃	l ₄	l ₅		
12,030	+0,004	12	151	44	45	106	100	6	30612543
12,040	+0,004	12	151	44	45	106	100	6	30612544
12,050	+0,004	12	151	44	45	106	100	6	30612545
13,000	H7	12	151	44	45	106	100	6	30612546
14,000	H7	16	160	47	48	112	106	6	30612547
15,000	H7	16	162	50	48	114	108	6	30612548
16,000	H7	16	170	52	48	122	116	6	30612549
17,000	H7	18	175	52	48	127	121	6	30612550
18,000	H7	18	182	52	48	134	128	6	30612551
19,000	H7	20	189	52	50	139	133	6	30612552
20,000	H7	20	195	52	50	145	139	6	30612553

Configurable features



Bore diameter tolerance ≥ IT6:
 - Diameter in increments of 0.001 mm freely selectable
 - Can be ordered in tolerance ≥ IT6



Specification:
 B040211[Diameter][Tolerance]

G variant (see page 303):
 - Diameter in increments of 0.001 mm freely selectable
 - Can be ordered from tolerances ≥ 4 μm

G variant specification:
 B040211[Diameter][Tolerance]

IT6 tolerance example:
 B040211-Ø16.350H6

Bore diameter d₁ = 16.350 H6

G variant example:
 B040211-Ø16.350-4

Special tool diameter d₁ = 16.350 -4 μm

Dimensions of configurable series IT6

d ₁	d ₂ h6	l ₁	l ₂	l ₃	l ₄	l ₅	z
0,950-1,060 ⁽¹⁾	3	50	6	28	22	17,5	3
1,061-1,320 ⁽¹⁾	3	50	9	28	22	17,5	3
1,321-1,500 ⁽¹⁾	3	50	9	28	22	18	3
1,501-1,700 ⁽¹⁾	3	50	10	28	22	18	3
1,701-1,900 ⁽¹⁾	3	50	11	28	22	18,5	4
1,901-2,360 ⁽¹⁾	3	50	12	28	22	18,5	4
2,361-2,650 ⁽¹⁾	3	60	16	28	32	29	4
2,651-2,800 ⁽¹⁾	4	65	17	28	37	33	6
2,801-3,030 ⁽²⁾	4	65	17	28	37	33	6
3,031-3,350	4	65	18	28	37	33	6
3,351-3,750	4	75	18	28	47	43	6
3,751-4,250	4	75	19	28	47	43	6
4,251-4,750	6	80	21	36	44	39	6
4,751-5,300	6	93	23	36	57	52	6
5,301-6,030 ⁽²⁾	6	93	26	36	57	53	6
6,031-6,700	6	101	28	36	65	61	6
6,701-7,500	8	109	31	36	73	68	6
7,501-8,500	8	117	33	36	81	77	6
8,501-9,500	10	125	36	40	85	80	6
9,501-10,600	10	133	38	40	93	88	6
10,601-11,800	10	142	41	40	102	97	6
11,801-13,200	12	151	44	45	106	100	6
13,201-14,000	16	160	47	48	112	106	6
14,001-15,000	16	162	50	48	114	108	6
15,001-16,000	16	170	52	48	122	116	6
16,001-17,000	18	175	52	48	127	121	6
17,001-18,000	18	182	52	48	134	128	6
18,001-19,000	20	189	52	50	139	133	6
19,001-20,000	20	195	52	50	145	139	6

(1) ≤ d₁ 3.000 mm only IT7 possible.

(2) Minimal deviation from the standard for manufacturing reasons.

Dimensions in mm.

For cutting data recommendations, see end of chapter.

Special designs and possible coatings available upon request.

* Only inductive shrink units are to be used for tools with brazed indexable blades.

NC machine reamer | B043211

Fixed design with straight shank diameters suitable for connection in hydraulic chucks, high-accuracy chucks and shrink chucks*

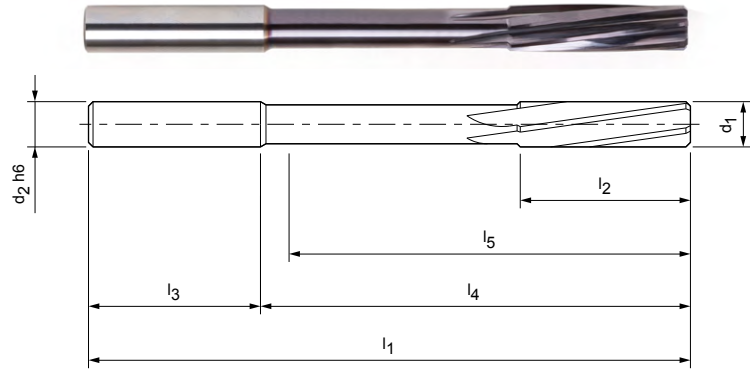

Design:

- Diameter: 0.950 - 20.000 mm
- Cutting direction: Right-hand cutting
- Cutting material: Carbide, TiAlN-coated (HP146)
- Groove direction: Spiral fluted ($\varnothing \leq 13$ mm)
Left-hand fluted ($\varnothing \geq 14$ mm)
- Geometry: EU spacing (from $\varnothing 3$ mm)

Special feature:

- $\varnothing 1$ to 3.5 mm: Solid carbide design with centre points on both sides.
- $\varnothing 3.97$ to 13 mm: Solid carbide design with internal centre.
- $\varnothing 14$ to 20 mm: Left-hand fluted design with brazed carbide indexable blades and steel shank.



Preferred series in H7

Dimensions							z	Order no.
d ₁ H7	d ₂ h6	l ₁	l ₂	l ₃	l ₄	l ₅		
1,000	3	50	6	28	22	17,5	3	30612554
1,200	3	50	9	28	22	17,5	3	30612555
1,500	3	50	9	28	22	18	3	30612556
1,600	3	50	10	28	22	18	3	30612557
1,800	3	50	11	28	22	18,5	4	30612558
2,000	3	50	12	28	22	18,5	4	30612559
2,200	3	50	12	28	22	18,5	4	30612560
2,500	3	60	16	28	32	29	4	30612561
3,000	4	65	17	28	37	33	6	30612562
3,200	4	65	18	28	37	33	6	30612563
3,500	4	75	18	28	47	43	6	30612564
4,000	4	75	19	28	47	43	6	30612565
4,500	6	80	21	36	44	39	6	30612566
5,000	6	93	23	36	57	52	6	30612567
5,500	6	93	26	36	57	53	6	30612568
6,000	6	93	26	36	57	53	6	30612569
6,500	6	101	28	36	65	61	6	30612570
7,000	8	109	31	36	73	68	6	30612571
7,500	8	109	31	36	73	68	6	30612572
8,000	8	117	33	36	81	77	6	30612573
8,500	8	117	33	36	81	77	6	30612574
9,000	10	125	36	40	85	80	6	30612575
9,500	10	125	36	40	85	80	6	30612576
10,000	10	133	38	40	93	88	6	30612577
10,500	10	133	38	40	93	88	6	30612578
11,000	10	142	41	40	102	97	6	30612579
12,000	12	151	44	45	106	100	6	30612580
13,000	12	151	44	45	106	100	6	30612581
14,000	16	160	47	48	112	106	6	30612582
15,000	16	162	50	48	114	108	6	30612583
16,000	16	170	52	48	122	116	6	30612584
17,000	18	175	52	48	127	121	6	30612585
18,000	18	182	52	48	134	128	6	30612586
19,000	20	189	52	50	139	133	6	30612587
20,000	20	195	52	50	145	139	6	30612588

Configurable features



Bore diameter tolerance \geq IT6:
 - Diameter in increments of 0.001 mm freely selectable
 - Can be ordered in tolerance \geq IT6



Specification:
 B043211[**Diameter**][**Tolerance**]

G variant (see page 303):
 - Diameter in increments of 0.001 mm freely selectable
 - Can be ordered from tolerances \geq 4 μ m

G variant specification:
 B043211[**Diameter**][**Tolerance**]

IT6 tolerance example:
 B043211- **\varnothing 16.350H6**

Bore diameter $d_1 = 16.350$ H6

G variant example:
 B043211- **\varnothing 16.350-4**

Special tool diameter $d_1 = 16.350 -4 \mu$ m

Dimensions of configurable series IT6

d_1	d_2 h6	l_1	l_2	l_3	l_4	l_5	z
0,950-1,060 ⁽¹⁾	3	50	6	28	22	17,5	3
1,061-1,320 ⁽¹⁾	3	50	9	28	22	17,5	3
1,321-1,500 ⁽¹⁾	3	50	9	28	22	18	3
1,501-1,700 ⁽¹⁾	3	50	10	28	22	18	3
1,701-1,900 ⁽¹⁾	3	50	11	28	22	18,5	4
1,901-2,360 ⁽¹⁾	3	50	12	28	22	18,5	4
2,361-2,650 ⁽¹⁾	3	60	16	28	32	29	4
2,651-2,800 ⁽¹⁾	4	65	17	28	37	33	6
2,801-3,030 ⁽²⁾	4	65	17	28	37	33	6
3,031-3,350	4	65	18	28	37	33	6
3,351-3,750	4	75	18	28	47	43	6
3,751-4,250	4	75	19	28	47	43	6
4,251-4,750	6	80	21	36	44	39	6
4,751-5,300	6	93	23	36	57	52	6
5,301-6,030 ⁽²⁾	6	93	26	36	57	53	6
6,031-6,700	6	101	28	36	65	61	6
6,701-7,500	8	109	31	36	73	68	6
7,501-8,500	8	117	33	36	81	77	6
8,501-9,500	10	125	36	40	85	80	6
9,501-10,600	10	133	38	40	93	88	6
10,601-11,800	10	142	41	40	102	97	6
11,801-13,200	12	151	44	45	106	100	6
13,201-14,000	16	160	47	48	112	106	6
14,001-15,000	16	162	50	48	114	108	6
15,001-16,000	16	170	52	48	122	116	6
16,001-17,000	18	175	52	48	127	121	6
17,001-18,000	18	182	52	48	134	128	6
18,001-19,000	20	189	52	50	139	133	6
19,001-20,000	20	195	52	50	145	139	6

(1) $\leq d_1$ 3.000 mm only IT7 possible.

(2) Minimal deviation from the standard for manufacturing reasons.

Dimensions in mm.

For cutting data recommendations, see end of chapter.

Special designs and possible coatings available upon request.

* Only inductive shrink units are to be used for tools with brazed indexable blades.

NC machine reamer | B040245

Fixed design with straight shank diameters suitable for connection in hydraulic chucks, high-accuracy chucks and shrink chucks*

Design:

Diameter: 20.001 - 30.200 mm
 Cutting direction: Right-hand cutting
 Cutting material: Carbide, uncoated (HU613)
 Groove direction: Left-hand fluted
 Geometry: EU spacing

Special feature:

Design with brazed carbide indexable blades and steel shank.

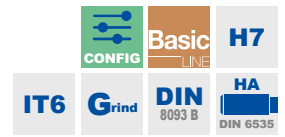
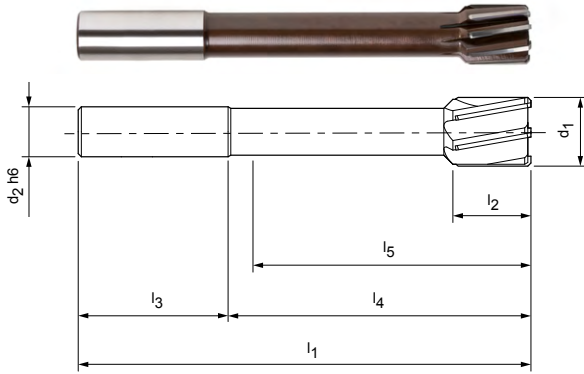

Preferred series in H7

Dimensions							z	Order no.
d ₁ H7	d ₂ h6	l ₁	l ₂	l ₃	l ₄	l ₅		
21,000	20	160	25	50	110	105	6	30215791
22,000	20	160	25	50	110	105	6	30215792
23,000	20	180	25	50	130	125	6	30242804
24,000	20	180	25	50	130	125	8	30109462
25,000	20	180	25	50	130	125	8	30109464
26,000	20	180	25	50	130	125	8	30109466
27,000	20	180	25	50	130	125	8	30242816
28,000	25	180	25	56	124	119	8	30109468
29,000	25	180	25	56	124	119	8	30242817
30,000	25	200	25	56	144	139	8	30109470

Configurable features

**Bore diameter tolerance \geq IT6:**

- Diameter in increments of 0.001 mm freely selectable
- Can be ordered in tolerance \geq IT6

**Specification:**

B040245[Diameter][Tolerance]

G variant (see page 303):

- Diameter in increments of 0.001 mm freely selectable
- Can be ordered from tolerances $\geq 4 \mu\text{m}$

G variant specification:

B040245[Diameter][Tolerance]

IT6 tolerance example:B040245-**Ø26.350H6**Bore diameter $d_1 = 26.350 \text{ H6}$ **G variant example:**B040245-**Ø26.350-4**Special tool diameter $d_1 = 26.350 -4 \mu\text{m}$

Dimensions of configurable series IT6

d_1	$d_2 \text{ h6}$	l_1	l_2	l_3	l_4	l_5	z
20,001-22,200	20	160	25	50	110	105	6
22,201-23,200	20	180	25	50	130	125	6
23,201-27,200	20	180	25	50	130	125	8
27,201-29,200	25	180	25	56	124	119	8
29,201-30,200	25	200	25	56	144	139	8

Dimensions in mm.

For cutting data recommendations, see end of chapter.

Special designs and possible coatings available upon request.

* Only inductive shrink units are to be used for tools with brazed indexable blades.

Machine reamer | B040200

Fixed design with long cutting section

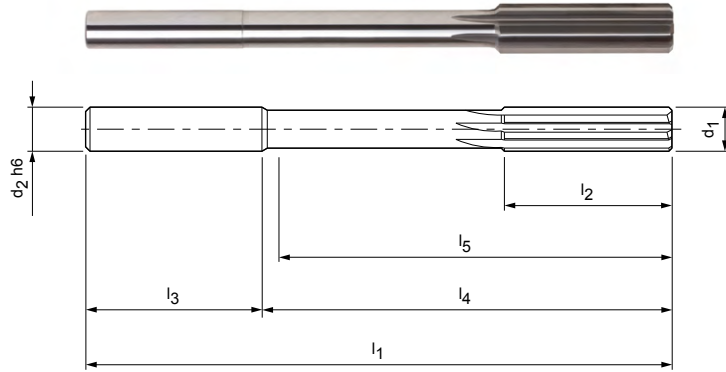

Design:

Diameter: 0.950 - 20.000 mm
 Cutting direction: Right-hand cutting
 Cutting material: Carbide, uncoated (HU613)
 Groove direction: Straight fluted
 Geometry: EU spacing (from \varnothing 3 mm)

Special feature:

\varnothing 1 to 3.5 mm: Solid carbide design with centre points on both sides.
 \varnothing 4 to 13 mm: Solid carbide design with internal centre.
 \varnothing 14 to 20 mm: Design with brazed carbide indexable blades and steel shank.
 Up to \varnothing 5.5 mm: Not standardised / sim. DIN 8093-1A.
 From \varnothing 6 mm: DIN 8093-1A.

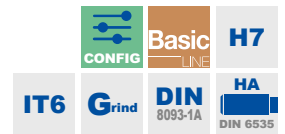

Preferred series in H7

Dimensions							z	Order no.
d_1 H7	d_2 h6	l_1	l_2	l_3	l_4	l_5		
1,000	1	34	5,5	19	15	13	3	30612359
1,200	1,2	38	7,5	21,5	16,5	14,5	3	30612360
1,500	1,5	40	8	22	18	16	3	30612361
1,600	1,6	43	9	23	20	18	3	30612362
1,800	1,8	46	10	24	22	20	4	30612363
2,000	2	49	11	25	24	22	4	30612364
2,200	2,2	53	12	28	25	22	4	30612365
2,500	2,5	57	14	28	29	26	4	30612366
3,000	3	61	15	28	33	30	6	30612367
3,200	3,2	65	16	28	37	34	6	30612368
3,500	3,5	70	18	28	42	39	6	30612369
4,000	4	75	19	28	47	43	6	30612370
4,500	4,5	80	21	28	52	48	6	30612371
5,000	5	86	23	28	58	54	6	30612372
5,500	5,6	93	26	36	57	53	6	30612373
6,000	5,6	93	26	36	57	53	6	30612374
6,500	6,3	101	28	36	65	61	6	30612375
7,000	7,1	109	31	36	73	68	6	30612376
7,500	7,1	109	31	36	73	68	6	30612377
8,000	8	117	33	36	81	77	6	30612378
8,500	8	117	33	36	81	77	6	30612379
9,000	9	125	36	40	85	80	6	30612618
9,500	9	125	36	40	85	80	6	30612380
10,000	10	133	38	40	93	88	6	30612381
10,500	10	133	38	40	93	88	6	30612382
11,000	10	142	41	40	102	97	6	30612383
12,000	10	151	44	40	111	106	6	30612384
13,000	10	151	44	40	111	106	6	30612385
14,000	12,5	160	47	45	115	110	6	30612386
15,000	12,5	162	50	45	117	112	6	30612387
16,000	12,5	170	52	45	125	120	6	30612388
17,000	14	175	54	45	130	125	6	30612389
18,000	14	182	56	45	137	132	6	30612390
19,000	16	189	58	48	141	136	6	30612391
20,000	16	195	60	48	147	142	6	30612392

Configurable features



Bore diameter tolerance \geq IT6:
 - Diameter in increments of 0.001 mm freely selectable
 - Can be ordered in tolerance \geq IT6



Specification:
 B040200[Diameter][Tolerance]

G variant (see page 303):
 - Diameter in increments of 0.001 mm freely selectable
 - Can be ordered from tolerances $\geq 4 \mu\text{m}$

G variant specification:
 B040200[Diameter][Tolerance]

IT6 tolerance example:
 B040200-Ø16.350H6

Bore diameter $d_1 = 16.350 \text{ H6}$

G variant example:
 B040200-Ø16.350-4

Special tool diameter $d_1 = 16.350 -4 \mu\text{m}$

Dimensions of configurable series IT6

d_1	$d_2 \text{ h6}$	l_1	l_2	l_3	l_4	l_5	z
0,950-1,060 ⁽¹⁾	1	34	5,5	19	15	13	3
1,061-1,180 ⁽¹⁾	1,1	36	6,5	20,5	15,5	13,5	3
1,181-1,320 ⁽¹⁾	1,2	38	7,5	21,5	16,5	14,5	3
1,321-1,500 ⁽¹⁾	1,5	40	8	22	18	16	3
1,501-1,700 ⁽¹⁾	1,6	43	9	23	20	18	3
1,701-1,900 ⁽¹⁾	1,8	46	10	24	22	20	4
1,901-2,120 ⁽¹⁾	2	49	11	25	24	22	4
2,121-2,360 ⁽¹⁾	2,2	53	12	28	25	22	4
2,361-2,650 ⁽¹⁾	2,5	57	14	28	29	26	4
2,651-3,030 ⁽¹⁾	3	61	15	28	33	30	6
3,031-3,350	3,2	65	16	28	37	34	6
3,351-3,750	3,5	70	18	28	42	39	6
3,751-4,250	4	75	19	28	47	43	6
4,251-4,750	4,5	80	21	28	52	48	6
4,751-5,300	5	86	23	28	58	54	6
5,301-6,030 ⁽²⁾	5,6	93	26	36	57	53	6
6,031-6,700	6,3	101	28	36	65	61	6
6,701-7,500	7,1	109	31	36	73	68	6
7,501-8,500	8	117	33	36	81	77	6
8,501-9,500	9	125	36	40	85	80	6
9,501-10,600	10	133	38	40	93	88	6
10,601-11,800	10	142	41	40	102	97	6
11,801-13,200	10	151	44	40	111	106	6
13,201-14,000	12,5	160	47	45	115	110	6
14,001-15,000	12,5	162	50	45	117	112	6
15,001-16,000	12,5	170	52	45	125	120	6
16,001-17,000	14	175	54	45	130	125	6
17,001-18,000	14	182	56	45	137	132	6
18,001-19,000	16	189	58	48	141	136	6
19,001-20,000	16	195	60	48	147	142	6

(1) $\leq d_1$ 3.000 mm only IT7 possible.

(2) Minimal deviation from the standard for manufacturing reasons.

Dimensions in mm.

For cutting data recommendations, see end of chapter.

Special designs and possible coatings available upon request.

Machine reamer | B040201

Fixed design with long cutting section

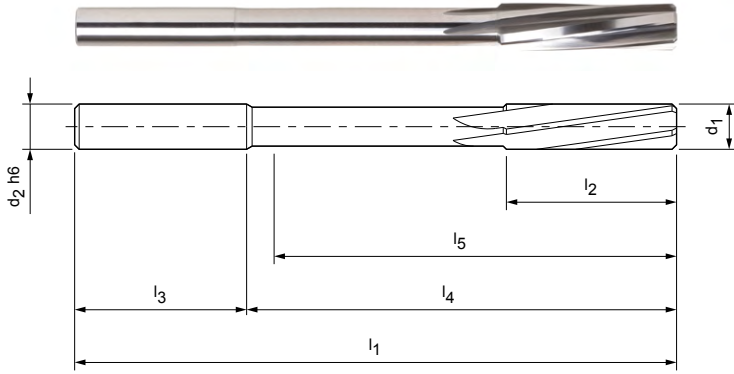

Design:
 Diameter: 0.950 - 20.000 mm
 Cutting direction: Right-hand cutting
 Cutting material: Carbide, uncoated (HU613)
 Groove direction: Spiral fluted ($\phi \leq 13$ mm)
 Left-hand fluted ($\phi \geq 14$ mm)
 Geometry: EU spacing (from $\phi 3$ mm)

Special feature:
 $\phi 1$ to 3.5 mm: Solid carbide design with centre points on both sides.
 $\phi 4$ to 13 mm: Solid carbide design with internal centre.
 $\phi 14$ to 20 mm: Design with brazed carbide indexable blades and steel shank.
 Up to $\phi 5.5$ mm: Not standardised / sim. DIN 8093-1B.
 From $\phi 6$ mm: DIN 8093-1B.

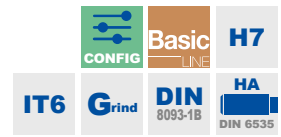

Preferred series in H7

Dimensions							z	Order no.
d_1 H7	d_2 h6	l_1	l_2	l_3	l_4	l_5		
1,000	1	34	5,5	19	15	13	3	30612393
1,200	1,2	38	7,5	21,5	16,5	14,5	3	30612394
1,500	1,5	40	8	22	18	16	3	30612395
1,600	1,6	43	9	23	20	18	3	30612396
1,800	1,8	46	10	24	22	20	4	30612397
2,000	2	49	11	25	24	22	4	30612398
2,200	2,2	53	12	28	25	22	4	30612399
2,500	2,5	57	14	28	29	26	4	30612400
3,000	3	61	15	28	33	30	6	30612401
3,200	3,2	65	16	28	37	34	6	30612402
3,500	3,5	70	18	28	42	39	6	30612403
4,000	4	75	19	28	47	43	6	30612404
4,500	4,5	80	21	28	52	48	6	30612405
5,000	5	86	23	28	58	54	6	30612406
5,500	5,6	93	26	36	57	53	6	30612407
6,000	5,6	93	26	36	57	53	6	30612408
6,500	6,3	101	28	36	65	61	6	30612409
7,000	7,1	109	31	36	73	68	6	30612410
7,500	7,1	109	31	36	73	68	6	30612411
8,000	8	117	33	36	81	77	6	30612412
8,500	8	117	33	36	81	77	6	30612413
9,000	9	125	36	40	85	80	6	30612619
9,500	9	125	36	40	85	80	6	30612414
10,000	10	133	38	40	93	88	6	30612415
10,500	10	133	38	40	93	88	6	30612416
11,000	10	142	41	40	102	97	6	30612417
12,000	10	151	44	40	111	106	6	30612418
13,000	10	151	44	40	111	106	6	30612419
14,000	12,5	160	47	45	115	110	6	30612420
15,000	12,5	162	50	45	117	112	6	30612421
16,000	12,5	170	52	45	125	120	6	30612422
17,000	14	175	54	45	130	125	6	30612423
18,000	14	182	56	45	137	132	6	30612424
19,000	16	189	58	48	141	136	6	30612425
20,000	16	195	60	48	147	142	6	30612426

Configurable features



Bore diameter tolerance \geq IT6:
 - Diameter in increments of 0.001 mm freely selectable
 - Can be ordered in tolerance \geq IT6



Specification:
 B040201[Diameter][Tolerance]

G variant (see page 303):
 - Diameter in increments of 0.001 mm freely selectable
 - Can be ordered from tolerances $\geq 4 \mu\text{m}$

G variant specification:
 B040201[Diameter][Tolerance]

IT6 tolerance example:
 B040201-Ø16.350H6

Bore diameter $d_1 = 16.350 \text{ H6}$

G variant example:
 B040201-Ø16.350-4

Special tool diameter $d_1 = 16.350 -4 \mu\text{m}$

Dimensions of configurable series IT6

d_1	$d_2 \text{ h6}$	l_1	l_2	l_3	l_4	l_5	z
0,950-1,060 ⁽¹⁾	1	34	5,5	19	15	13	3
1,061-1,180 ⁽¹⁾	1,1	36	6,5	20,5	15,5	13,5	3
1,181-1,320 ⁽¹⁾	1,2	38	7,5	21,5	16,5	14,5	3
1,321-1,500 ⁽¹⁾	1,5	40	8	22	18	16	3
1,501-1,700 ⁽¹⁾	1,6	43	9	23	20	18	3
1,701-1,900 ⁽¹⁾	1,8	46	10	24	22	20	4
1,901-2,120 ⁽¹⁾	2	49	11	25	24	22	4
2,121-2,360 ⁽¹⁾	2,2	53	12	28	25	22	4
2,361-2,650 ⁽¹⁾	2,5	57	14	28	29	26	4
2,651-3,030 ⁽¹⁾	3	61	15	28	33	30	6
3,031-3,350	3,2	65	16	28	37	34	6
3,351-3,750	3,5	70	18	28	42	39	6
3,751-4,250	4	75	19	28	47	43	6
4,251-4,750	4,5	80	21	28	52	48	6
4,751-5,300	5	86	23	28	58	54	6
5,301-6,030 ⁽²⁾	5,6	93	26	36	57	53	6
6,031-6,700	6,3	101	28	36	65	61	6
6,701-7,500	7,1	109	31	36	73	68	6
7,501-8,500	8	117	33	36	81	77	6
8,501-9,500	9	125	36	40	85	80	6
9,501-10,600	10	133	38	40	93	88	6
10,601-11,800	10	142	41	40	102	97	6
11,801-13,200	10	151	44	40	111	106	6
13,201-14,000	12,5	160	47	45	115	110	6
14,001-15,000	12,5	162	50	45	117	112	6
15,001-16,000	12,5	170	52	45	125	120	6
16,001-17,000	14	175	54	45	130	125	6
17,001-18,000	14	182	56	45	137	132	6
18,001-19,000	16	189	58	48	141	136	6
19,001-20,000	16	195	60	48	147	142	6

(1) $\leq d_1$ 3.000 mm only IT7 possible.

(2) Minimal deviation from the standard for manufacturing reasons.

Dimensions in mm.

For cutting data recommendations, see end of chapter.

Special designs and possible coatings available upon request.

Reamer for automatic lathes | B040230

Fixed design, short design

Design:

Diameter: 2.890 - 12.200 mm
 Cutting direction: Right-hand cutting
 Cutting material: Solid carbide, uncoated (HU613)
 Groove direction: spiral fluted

Special feature:

Up to \varnothing 5.5 mm: Not standardised / sim. DIN 8090.
 From \varnothing 6 mm: DIN 8090.

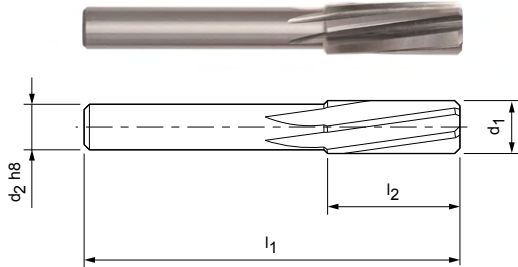

Preferred series in H7

Dimensions				z	Order no.
d ₁ H7	d ₂ h8	l ₁	l ₂		
3,000	2,5	56	20	6	30109291
3,200	2,8	56	20	6	30109292
3,500	3	56	20	6	30109293
4,000	3,55	56	20	6	30109294
4,500	4	63	22	6	30109295
5,000	4	63	22	6	30109296
5,500	5	63	22	6	30109297
6,000	5	63	22	6	30109298
6,500	5	63	22	6	30109299
7,000	6,3	71	25	6	30109300
7,500	6,3	71	25	6	30109301
8,000	6,3	71	25	6	30109302
8,500	6,3	71	25	6	30109303
9,000	8	71	25	6	30109304
9,500	8	71	25	6	30109305
10,000	8	71	25	6	30109306
10,500	8	71	25	6	30109307
11,000	10	80	28	6	30109308
11,500	10	80	28	6	30109309
12,000	10	80	28	6	30109310

Configurable features

**Bore diameter tolerance \geq IT6:**

- Diameter in increments of 0.001 mm freely selectable
- Can be ordered in tolerance \geq IT6

**Specification:**

B040230[Diameter][Tolerance]

G variant (see page 303):

- Diameter in increments of 0.001 mm freely selectable
- Can be ordered from tolerances $\geq 4 \mu\text{m}$

G variant specification:

B040230[Diameter][Tolerance]

IT6 tolerance example:

B040230-Ø10.350H6

Bore diameter $d_1 = 10.350 \text{ H6}$ **G variant example:**

B040230-Ø10.350-4

Special tool diameter $d_1 = 10.350 -4 \mu\text{m}$

Dimensions of configurable series IT6

d_1	$d_2 \text{ h8}$	l_1	l_2	z
2,890-3,100 ⁽¹⁾	2,5	56	20	6
3,101-3,300	2,8	56	20	6
3,301-3,700	3	56	20	6
3,701-4,250	3,55	56	20	6
4,251-5,300	4	63	22	6
5,301-6,700	5	63	22	6
6,701-8,200	6,3	71	25	6
8,201-8,700 ⁽²⁾	6,3	71	25	6
8,701-10,600	8	71	25	6
10,601-12,200	10	80	28	6

(1) $\leq d_1 3.000 \text{ mm}$ only IT7 possible.

(2) Minimal deviation from the standard for manufacturing reasons.

Dimensions in mm.

For cutting data recommendations, see end of chapter.

Special designs and possible coatings available upon request.

Machine reamer | B040420

Fixed design with morse taper shank, long cutting section and solid carbide head

Design:

Diameter: 4.750 - 16.200 mm
 Cutting direction: Right-hand cutting
 Cutting material: Solid carbide, uncoated (HU613)
 Groove direction: Straight fluted
 Geometry: EU spacing

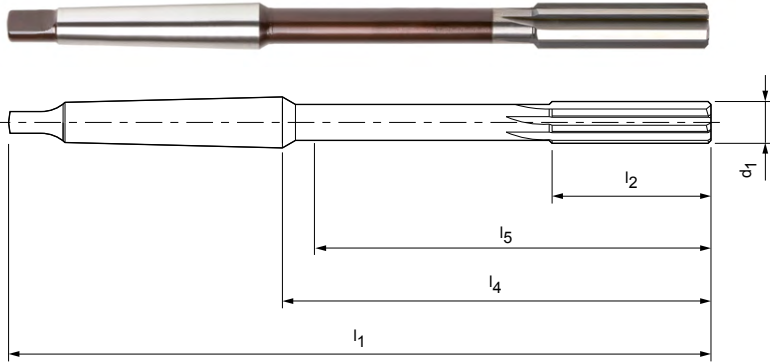

Preferred series in H7

Dimensions						z	Order no.
d_1 H7	MK	l_1	l_2	l_4	l_5		
5,000	1	133	23	67,5	57	6	30109892
5,500	1	138	26	72,5	62	6	30312290
6,000	1	138	26	72,5	62	6	30109894
6,500	1	144	28	78,5	69	6	30312291
7,000	1	150	31	84,5	75	6	30109896
7,500	1	150	31	84,5	76	6	30312292
8,000	1	156	33	90,5	82	6	30109898
8,500	1	156	33	90,5	82	6	30312293
9,000	1	162	36	96,5	89	6	30109900
9,500	1	162	36	96,5	89	6	30312294
10,000	1	168	38	102,5	95	6	30109902
10,500	1	168	38	102,5	96	6	30312295
11,000	1	175	41	109,5	104	6	30109904
12,000	1	182	44	116,5	111	6	30109906
13,000	1	182	44	116,5	111	6	30109908
14,000	1	189	47	123,5	118	8	30109910
15,000	2	204	50	124	116	8	30109912
16,000	2	210	52	130	123	8	30109914

Configurable features



Bore diameter tolerance \geq IT6:
 - Diameter in increments of 0.001 mm freely selectable
 - Can be ordered in tolerance \geq IT6



Specification:
 B040420[**Diameter**][**Tolerance**]

G variant (see page 303):
 - Diameter in increments of 0.001 mm freely selectable
 - Can be ordered from tolerances $\geq 4 \mu\text{m}$

G variant specification:
 B040420[**Diameter**][**Tolerance**]

IT6 tolerance example:
 B040420- **\emptyset 10.350H6**

Bore diameter $d_1 = 10.350 \text{ H6}$

G variant example:
 B040420- **\emptyset 10.350-4**

Special tool diameter $d_1 = 10.350 -4 \mu\text{m}$

Dimensions of configurable series IT6

d_1	MK	l_1	l_2	l_4	l_5	z
4,750-5,300	1	133	23	67,5	57	6
5,301-6,110	1	138	26	72,5	62	6
6,111-6,700	1	144	28	78,5	69	6
6,701-7,200	1	150	31	84,5	75	6
7,201-7,700	1	150	31	84,5	76	6
7,701-8,700	1	156	33	90,5	82	6
8,701-9,700	1	162	36	96,5	89	6
9,701-10,200	1	168	38	102,5	95	6
10,201-10,700	1	168	38	102,5	96	6
10,701-11,700	1	175	41	109,5	104	6
11,701-13,200	1	182	44	116,5	111	6
13,201-14,200	1	189	47	123,5	118	8
14,201-15,200	2	204	50	124	116	8
15,201-16,200	2	210	52	130	123	8

Dimensions in mm.

For cutting data recommendations, see end of chapter.

Special designs and possible coatings available upon request.

Machine reamer | B040422

Fixed design with morse taper shank, long cutting section and solid carbide head

Design:

Diameter: 4.750 - 16.200 mm
 Cutting direction: Right-hand cutting
 Cutting material: Solid carbide, uncoated (HU613)
 Groove direction: Spiral fluted
 Geometry: EU spacing

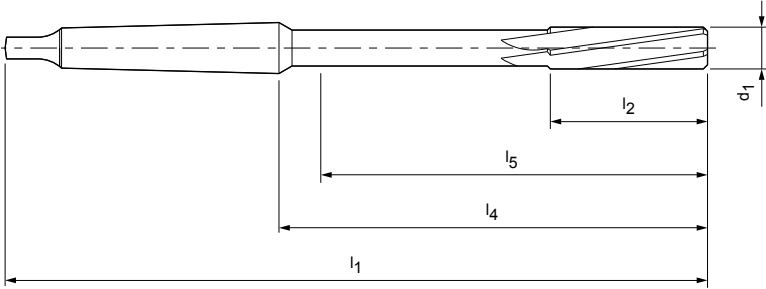

Preferred series in H7

Dimensions						z	Order no.
d ₁ H7	MK	l ₁	l ₂	l ₄	l ₅		
5,000	1	133	23	67,5	57	6	30109960
5,500	1	138	26	72,5	62	6	30312307
6,000	1	138	26	72,5	62	6	30109962
6,500	1	144	28	78,5	69	6	30312309
7,000	1	150	31	84,5	75	6	30109964
7,500	1	150	31	84,5	76	6	30312310
8,000	1	156	33	90,5	82	6	30109966
8,500	1	156	33	90,5	82	6	30312312
9,000	1	162	36	96,5	89	6	30109968
9,500	1	162	36	96,5	89	6	30312313
10,000	1	168	38	102,5	95	6	30109970
10,500	1	168	38	102,5	96	6	30312316
11,000	1	175	41	109,5	104	6	30109972
12,000	1	182	44	116,5	111	6	30109974
13,000	1	182	44	116,5	111	6	30109976
14,000	1	189	47	123,5	118	8	30109978
15,000	2	204	50	124	116	8	30109980
16,000	2	210	52	130	123	8	30109982

Configurable features



Bore diameter tolerance \geq IT6:
 - Diameter in increments of 0.001 mm freely selectable
 - Can be ordered in tolerance \geq IT6



Specification:
 B040422[Diameter][Tolerance]

G variant (see page 303):
 - Diameter in increments of 0.001 mm freely selectable
 - Can be ordered from tolerances $\geq 4 \mu\text{m}$

G variant specification:
 B040422[Diameter][Tolerance]

IT6 tolerance example:
 B040422-Ø10.350H6

Bore diameter $d_1 = 10.350 \text{ H6}$

G variant example:
 B040422-Ø10.350-4

Special tool diameter $d_1 = 10.350 -4 \mu\text{m}$

Dimensions of configurable series IT6

d_1	MK	l_1	l_2	l_4	l_5	z
4,750-5,300	1	133	23	67,5	57	6
5,301-6,110	1	138	26	72,5	62	6
6,111-6,700	1	144	28	78,5	69	6
6,701-7,200	1	150	31	84,5	75	6
7,201-7,700	1	150	31	84,5	76	6
7,701-8,700	1	156	33	90,5	82	6
8,701-9,700	1	162	36	96,5	89	6
9,701-10,200	1	168	38	102,5	95	6
10,201-10,700	1	168	38	102,5	96	6
10,701-11,700	1	175	41	109,5	104	6
11,701-13,200	1	182	44	116,5	111	6
13,201-14,200	1	189	47	123,5	118	8
14,201-15,200	2	204	50	124	116	8
15,201-16,200	2	210	52	130	123	8

Dimensions in mm.

For cutting data recommendations, see end of chapter.

Special designs and possible coatings available upon request.

Machine reamer | B040421

Fixed design with morse taper shank, long cutting section and carbide indexable brazed blades

Design:

Diameter:

16.141 - 40.160 mm

Cutting direction:

Right-hand cutting

Cutting material:

 Carbide, uncoated
(HU613)

Groove direction:

Straight fluted

Geometry:

EU spacing

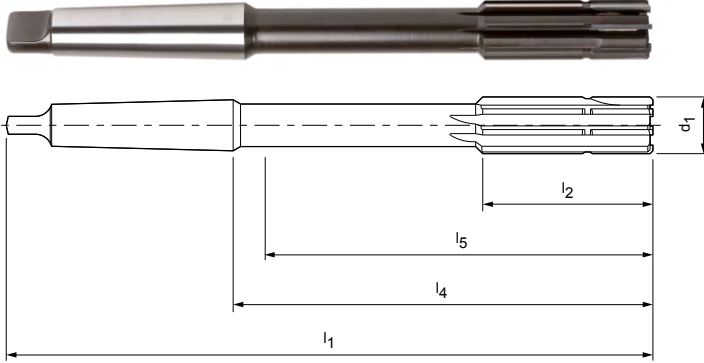
Preferred series in H7

Dimensions						z	Order no.
d_1 H7	MK	l_1	l_2	l_4	l_5		
17,000	2	214	54	134	128	6	30109922
18,000	2	219	56	139	133	6	30109924
19,000	2	223	58	143	137	6	30109926
20,000	2	228	60	148	142	6	30109928
21,000	2	232	62	152	146	6	30109930
22,000	2	237	64	157	151	6	30109932
23,000	2	241	66	161	155	6	30109934
24,000	3	268	68	169	162	8	30109936
25,000	3	268	68	169	162	8	30109938
26,000	3	273	70	174	167	8	30109940
27,000	3	277	71	178	171	8	30109942
28,000	3	277	71	178	171	8	30109944
30,000	3	281	73	182	175	8	30109946
32,000	4	317	77	193	186	8	30109948
34,000	4	321	78	197	190	8	30109950
35,000	4	321	78	197	190	8	30109952
36,000	4	325	79	201	194	8	30109954
38,000	4	329	81	205	198	8	30109956
40,000	4	329	81	205	198	8	30109958

Configurable features



Bore diameter tolerance \geq IT6:
 - Diameter in increments of 0.001 mm freely selectable
 - Can be ordered in tolerance \geq IT6



Specification:
 B040421[Diameter][Tolerance]

G variant (see page 303):
 - Diameter in increments of 0.001 mm freely selectable
 - Can be ordered from tolerances $\geq 4 \mu\text{m}$

G variant specification:
 B040421[Diameter][Tolerance]

IT6 tolerance example:
 B040421-Ø16.350H6

Bore diameter $d_1 = 16.350 \text{ H6}$

G variant example:
 B040421-Ø16.350-4

Special tool diameter $d_1 = 16.350 -4 \mu\text{m}$

Dimensions of configurable series IT6

d_1	MK	l_1	l_2	l_4	l_5	z
16,141-17,140	2	214	54	134	128	6
17,141-18,140	2	219	56	139	133	6
18,141-19,160	2	223	58	143	137	6
19,161-20,160	2	228	60	148	142	6
20,161-21,200	2	232	62	152	146	6
21,201-22,200	2	237	64	157	151	6
22,201-23,200	2	241	66	161	155	6
23,201-25,160	3	268	68	169	162	8
25,161-26,200	3	273	70	174	167	8
26,201-28,160	3	277	71	178	171	8
29,201-30,160	3	281	73	182	175	8
31,201-32,200	4	317	77	193	186	8
33,201-35,200	4	321	78	197	190	8
35,201-36,200	4	325	79	201	194	8
37,201-38,200	4	329	81	205	198	8
39,201-40,160	4	329	81	205	198	8

Intermediate diameters that are not covered by the \emptyset ranges listed can be custom made on request.

Dimensions in mm.

For cutting data recommendations, see end of chapter.

Special designs and possible coatings available upon request.

Machine reamer | B040423

Fixed design with morse taper shank, long cutting section and carbide indexable brazed blades

Design:

Diameter:

9.640 - 40.160 mm

Cutting direction:

Right-hand cutting

Cutting material:

 Carbide, uncoated
(HU613)

Groove direction:

Left-hand fluted

Geometry:

EU spacing

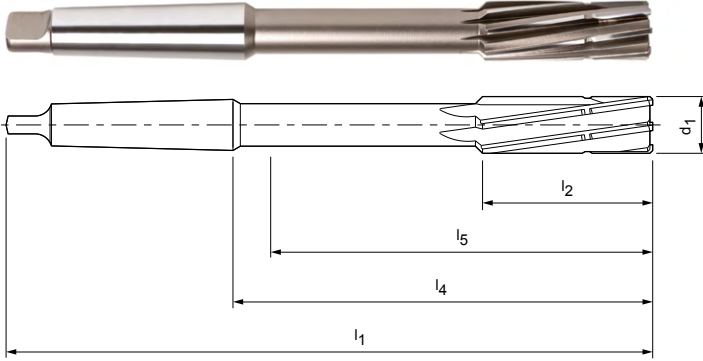
Preferred series in H7

Dimensions						z	Order no.
d_1 H7	MK	l_1	l_2	l_4	l_5		
10,000	1	168	38	102,5	96	6	30109984
10,500	1	168	38	102,5	96	6	30312621
11,000	1	175	41	109,5	103	6	30109986
11,500	1	175	41	109,5	104	6	30312622
12,000	1	182	44	116,5	112	6	30109988
13,000	1	182	44	116,5	112	6	30109990
14,000	1	189	47	123,5	118	6	30109992
15,000	2	204	50	124	116	6	30109994
16,000	2	210	52	130	123	6	30109996
17,000	2	214	54	134	128	6	30109998
18,000	2	219	56	139	133	6	30110000
19,000	2	223	58	143	137	6	30110002
20,000	2	228	60	148	142	6	30110004
21,000	2	232	62	152	146	6	30110006
22,000	2	237	64	157	151	6	30110008
23,000	2	241	66	161	155	6	30110010
24,000	3	268	68	169	162	8	30110012
25,000	3	268	68	169	162	8	30110014
26,000	3	273	70	174	167	8	30110016
27,000	3	277	71	178	171	8	30110018
28,000	3	277	71	178	171	8	30110020
29,000	3	281	73	182	175	8	30312623
30,000	3	281	73	182	175	8	30110022
31,000	3	285	75	186	179	8	30312624
32,000	4	317	77	193	186	8	30110024
34,000	4	321	78	197	190	8	30110026
35,000	4	321	78	197	190	8	30110028
36,000	4	325	79	201	194	8	30110030
38,000	4	329	81	205	198	8	30110032
40,000	4	329	81	205	198	8	30110034

Configurable features



Bore diameter tolerance \geq IT6:
 - Diameter in increments of 0.001 mm freely selectable
 - Can be ordered in tolerance \geq IT6



Specification:
 B040423[Diameter][Tolerance]

G variant (see page 303):
 - Diameter in increments of 0.001 mm freely selectable
 - Can be ordered from tolerances $\geq 4 \mu\text{m}$

G variant specification:
 B040423[Diameter][Tolerance]

IT6 tolerance example:
 B040423-Ø16.350H6

Bore diameter $d_1 = 16.350 \text{ H6}$

G variant example:
 B040423-Ø16.350-4

Special tool diameter $d_1 = 16.350 -4 \mu\text{m}$

Dimensions of configurable series IT6

d_1	MK	l_1	l_2	l_4	l_5	z
9,640-10,640	1	168	38	102,5	96	6
10,641-11,140	1	175	41	109,5	103	6
11,141-11,800	1	175	41	109,5	104	6
11,801-13,200	1	182	44	116,5	112	6
13,201-14,140	1	189	47	123,5	118	6
14,141-15,140	2	204	50	124	116	6
15,141-16,140	2	210	52	130	123	6
16,141-17,140	2	214	54	134	128	6
17,141-18,140	2	219	56	139	133	6
18,141-19,160	2	223	58	143	137	6
19,161-20,160	2	228	60	148	142	6
20,161-21,200	2	232	62	152	146	6
21,201-22,200	2	237	64	157	151	6
22,201-23,200	2	241	66	161	155	6
23,201-25,160	3	268	68	169	162	8
25,161-26,200	3	273	70	174	167	8
26,201-28,160	3	277	71	178	171	8
28,161-30,160	3	281	73	182	175	8
30,161-31,200	3	285	75	186	179	8
31,201-32,200	4	317	77	193	186	8
33,201-32,200	4	321	78	197	190	8
34,201-35,200	4	321	78	197	190	8
35,201-36,200	4	325	79	201	194	8
37,201-38,200	4	329	81	205	198	8
39,201-40,160	4	329	81	205	198	8

Intermediate diameters that are not covered by the \emptyset ranges listed can be custom made on request.

Dimensions in mm.

For cutting data recommendations, see end of chapter.

Special designs and possible coatings available upon request.

Machine expandable reamer | B040311

Expanding design with short cutting section and carbide indexable brazed blades

Design:

Diameter: 7.700 - 20.200 mm
 Cutting direction: Right-hand cutting
 Cutting material: Carbide, uncoated (HU613)
 Groove direction: Straight fluted

Special feature:

Expandable by approx. 0.03 mm with face bolt.

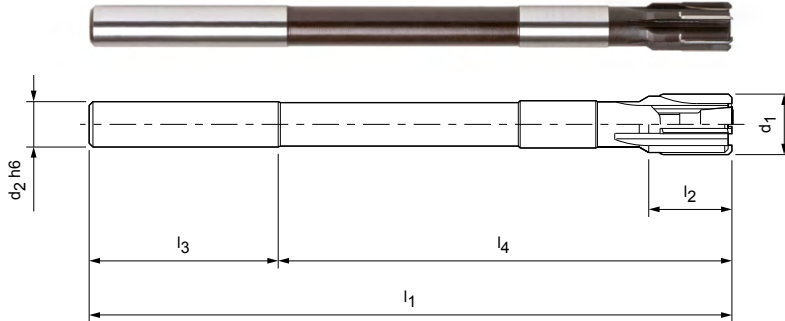

Preferred series in H7

Dimensions						z	Order no.
d_1 H7	d_2 h6	l_1	l_2	l_3	l_4		
8,000	8	117	12	42	75	4	30109517
8,500	8	117	12	42	75	4	30310349
9,000	10	125	12	46	79	6	30109519
9,500	10	125	12	46	79	6	30310350
10,000	10	133	12	46	87	6	30109521
10,500	10	133	12	46	87	6	30310352
11,000	10	142	12	46	96	6	30109523
11,500	10	142	12	46	96	6	30310354
12,000	10	151	12	46	105	6	30109525
12,500	10	151	12	46	105	6	30310361
13,000	10	151	12	46	105	6	30109527
14,000	12	160	16	50	110	6	30109529
15,000	12	162	16	50	112	6	30109531
16,000	12	170	19	50	120	6	30109533
17,000	14	175	19	52	123	6	30310362
18,000	14	182	19	52	130	6	30109535
19,000	16	189	19	58	131	6	30310364
20,000	16	195	19	58	137	6	30109537

Configurable features



Bore diameter tolerance \geq IT6:
 - Diameter in increments of 0.001 mm freely selectable
 - Can be ordered in tolerance \geq IT6



Specification:
 B040311[**Diameter**][**Tolerance**]

G variant (see page 303):
 - Diameter in increments of 0.001 mm freely selectable
 - Can be ordered from tolerances $\geq 4 \mu\text{m}$

G variant specification:
 B040311[**Diameter**][**Tolerance**]

IT6 tolerance example:
 B040311-**Ø10.350H6**

Bore diameter $d_1 = 10.350 \text{ H6}$

G variant example:
 B040311-**Ø10.350-4**

Special tool diameter $d_1 = 10.350 -4 \mu\text{m}$

Dimensions of configurable series IT6

d_1	$d_2 \text{ h6}$	l_1	l_2	l_3	l_4	z
7,700-8,700	8	117	12	42	75	4
8,701-9,700	10	125	12	46	79	6
9,701-10,700	10	133	12	46	87	6
10,701-11,700	10	142	12	46	96	6
11,701-12,700	10	151	12	46	105	6
12,701-13,200	10	151	12	46	105	6
13,201-14,200	12	160	16	50	110	6
14,201-15,200	12	162	16	50	112	6
15,201-16,200	12	170	19	50	120	6
16,201-17,200	14	175	19	52	123	6
17,201-18,200	14	182	19	52	130	6
18,201-19,200	16	189	19	58	131	6
19,201-20,200	16	195	19	58	137	6

Dimensions in mm.

For cutting data recommendations, see end of chapter.

Special designs and possible coatings available upon request.

Machine expandable reamer | B040511

Expanding design with morse taper shank, short cutting section and carbide indexable brazed blades

Design:

Diameter: 7.700 - 40.200 mm
 Cutting direction: Right-hand cutting
 Cutting material: Carbide, uncoated (HU613)
 Groove direction: Straight fluted

Special feature:

Expandable by approx. 0.03 mm with face bolt.

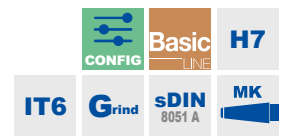
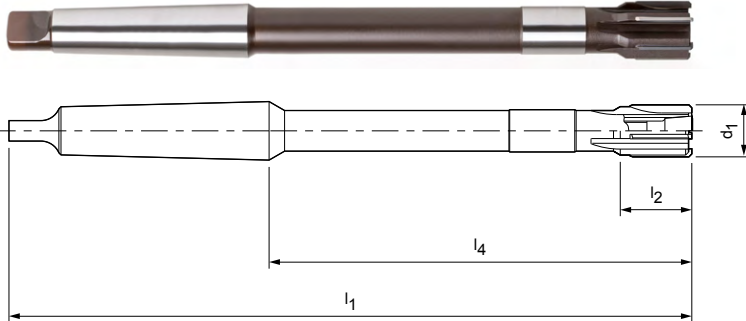
Preferred series in H7

Dimensions					z	Order no.
d ₁ H7	MK	l ₁	l ₂	l ₄		
8,000	1	156	12	90,5	4	30110098
8,500	1	156	12	90,5	4	30316589
9,000	1	162	19	96,5	4	30110100
9,500	1	162	12	96,5	6	30316591
10,000	1	168	12	102,5	6	30110102
10,500	1	168	12	102,5	6	30316597
11,000	1	175	12	109,5	6	30110104
11,500	1	175	12	109,5	6	30316598
12,000	1	182	12	116,5	6	30110106
12,500	1	182	12	116,5	6	30316599
13,000	1	182	12	116,5	6	30110108
14,000	1	189	16	123,5	6	30110110
15,000	2	204	16	124	6	30110112
16,000	2	210	19	130	6	30110114
17,000	2	214	19	134	6	30110116
18,000	2	219	19	139	6	30110118
19,000	2	223	19	143	6	30110120
20,000	2	228	19	148	6	30110122
21,000	2	232	19	152	6	30316603
22,000	2	237	22	157	6	30110124
23,000	2	241	22	161	6	30316605
24,000	3	268	22	169	6	30110126
25,000	3	268	22	169	6	30110128
26,000	3	273	22	174	6	30110130
27,000	3	277	25	178	6	30316607
28,000	3	277	25	178	6	30110132
30,000	3	281	25	182	6	30110134
32,000	4	317	25	193	6	30110136
34,000	4	321	25	197	8	30110138
35,000	4	321	25	197	8	30110140
36,000	4	325	25	201	8	30110142
38,000	4	329	25	205	8	30110144
40,000	4	329	25	205	8	30110146

Configurable features



Bore diameter tolerance \geq IT6:
 - Diameter in increments of 0.001 mm freely selectable
 - Can be ordered in tolerance \geq IT6



Specification:
 B040511[Diameter][Tolerance]

G variant (see page 303):
 - Diameter in increments of 0.001 mm freely selectable
 - Can be ordered from tolerances $\geq 4 \mu\text{m}$

G variant specification:
 B040511[Diameter][Tolerance]

IT6 tolerance example:
 B040511-Ø16.350H6

Bore diameter $d_1 = 16.350 \text{ H6}$

G variant example:
 B040511-Ø16.350-4

Special tool diameter $d_1 = 16.350 -4 \mu\text{m}$

Dimensions of configurable series IT6

d_1	MK	l_1	l_2	l_4	z
7,700-8,700	1	156	12	90,5	4
8,701-9,200	1	162	19	96,5	4
9,201-9,700	1	162	12	96,5	6
9,701-10,700	1	168	12	102,5	6
10,701-11,700	1	175	12	109,5	6
11,701-13,200	1	182	12	116,5	6
13,201-14,200	1	189	16	123,5	6
14,201-15,200	2	204	16	124	6
15,201-16,200	2	210	19	130	6
16,201-17,200	2	214	19	134	6
17,201-18,200	2	219	19	139	6
18,201-19,200	2	223	19	143	6
19,201-20,200	2	228	19	148	6
20,201-21,200	2	232	19	152	6
21,201-22,200	2	237	22	157	6
22,201-23,200	2	241	22	161	6
23,201-25,200	3	268	22	169	6
25,201-26,200	3	273	22	174	6
26,201-28,200	3	277	25	178	6
29,201-30,200	3	281	25	182	6
31,201-32,200	4	317	25	193	6
33,201-35,200	4	321	25	197	8
35,201-36,200	4	325	25	201	8
37,201-38,200	4	329	25	205	8
39,201-40,200	4	329	25	205	8

Intermediate diameters that are not covered by the \emptyset ranges listed can be custom made on request.

Dimensions in mm.

For cutting data recommendations, see end of chapter.

Special designs and possible coatings available upon request.

NC machine reamer | B030505

Fixed design with straight shank diameters suitable for connection in hydraulic chucks, high-precision chucks and shrink chucks

Design:

Diameter: 0.950 - 20.000 mm
 Cutting direction: Right-hand cutting
 Cutting material: HSS-E, uncoated (SU344)
 Groove direction: Spiral fluted

Special feature:

ø 1 - 3.5 mm: Design with centre points on both sides.
 ø 4 - 20 mm: Design with internal centre.

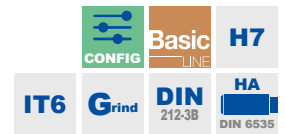
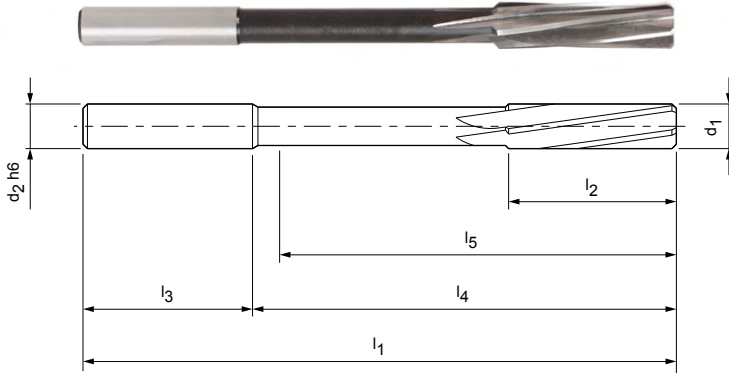

Preferred series available from stock in H7 | +0.004 mm | +0.005 mm

Dimensions								z	Order no.
d_1	Tolerance	$d_2 h_6$	l_1	l_2	l_3	l_4	l_5		
1,000	H7	1	34	5,5	19	15	12,5	3	30330779
1,010	+0,004	1	34	5,5	19	15	12,5	3	30103146
1,020	+0,004	1	34	5,5	19	15	12,5	3	30103147
1,100	H7	1	36	6,5	20,5	15,5	13	3	10082114
1,200	H7	2	38	7,5	21,5	16,5	14	3	30330781
1,400	H7	2	40	8	22	18	15,5	3	30330783
1,500	H7	2	40	8	22	18	15,5	3	30102976
1,510	+0,004	2	43	9	23	20	16	3	30103149
1,520	+0,004	2	43	9	23	20	16	3	30103150
1,600	H7	2	43	9	23	20	16	3	30102977
1,700	H7	2	43	9	23	20	16	3	30102978
1,800	H7	2	46	10	24	22	19	4	30102979
1,900	H7	2	46	10	24	22	19	4	30102980
1,970	+0,004	2	49	11	25	24	21	4	30103151
1,980	+0,004	2	49	11	25	24	21	4	30103152
1,990	+0,004	2	49	11	25	24	21	4	30103153
2,000	H7	2	49	11	25	24	21	4	30102981
2,010	+0,004	2	49	11	25	24	21	4	30103155
2,020	+0,004	2	49	11	25	24	21	4	30103156
2,100	H7	2	49	11	25	24	21	4	30102982
2,200	H7	3	53	12	28	25	22	4	30102983
2,300	H7	3	53	12	28	25	22	4	30102984
2,400	H7	3	57	14	28	29	26	4	30102985
2,480	+0,004	3	57	14	28	29	26	4	30103157
2,490	+0,004	3	57	14	28	29	26	4	30103158
2,500	H7	3	57	14	28	29	26	4	30102986
2,510	+0,004	3	57	14	28	29	26	4	30103160
2,520	+0,004	3	57	14	28	29	26	4	30103161
2,600	H7	3	57	14	28	29	26	4	30102987
2,700	H7	3	61	15	28	33	30	6	30102988
2,800	H7	3	61	15	28	33	30	6	30102989
2,900	H7	3	61	15	28	33	30	6	30102990
2,970	+0,004	3	61	15	28	33	30	6	30103162
2,980	+0,004	3	61	15	28	33	30	6	30103163
2,990	+0,004	3	61	15	28	33	30	6	30103164

NC machine reamer I B030505, fixed design according to DIN 212-3B

Dimensions								z	Order no.
d ₁	Tolerance	d ₂ h6	l ₁	l ₂	l ₃	l ₄	l ₅		
3,000	H7	3	61	15	28	33	30	6	30102991
3,010*	+0,004	3	61	15	28	33	30	6	30103166
3,020*	+0,004	3	61	15	28	33	30	6	30103167
3,100	H7	4	65	16	28	37	34	6	30102992
3,200	H7	4	65	16	28	37	34	6	30102993
3,300	H7	4	65	16	28	37	34	6	30102994
3,400	H7	4	70	18	28	42	39	6	30102995
3,500	H7	4	70	18	28	42	39	6	30102996
3,600	H7	4	70	18	28	42	39	6	30102997
3,700	H7	4	70	18	28	42	39	6	30102998
3,800	H7	4	75	19	28	47	44	6	30103000
3,900	H7	4	75	19	28	47	44	6	30103002
3,970	+0,004	4	75	19	28	47	44	6	30103169
3,980	+0,004	4	75	19	28	47	44	6	30103171
3,990	+0,004	4	75	19	28	47	44	6	30103173
4,000	H7	4	75	19	28	47	44	6	30103004
4,010	+0,004	4	75	19	28	47	44	6	30103177
4,020	+0,004	4	75	19	28	47	44	6	30103179
4,100	H7	4	75	19	28	47	44	6	30103006
4,200	H7	4	75	19	28	47	44	6	30103008
4,300	H7	5	80	21	28	52	48	6	30103010
4,400	H7	5	80	21	28	52	48	6	30103012
4,500	H7	5	80	21	28	52	48	6	30103014
4,600	H7	5	80	21	28	52	48	6	30103016
4,700	H7	5	80	21	28	52	48	6	30103018
4,800	H7	5	86	23	28	58	54	6	30103020
4,900	H7	5	86	23	28	58	54	6	30103022
4,970	+0,004	5	86	23	28	58	54	6	30103181
4,980	+0,004	5	86	23	28	58	54	6	30103183
4,990	+0,004	5	86	23	28	58	54	6	30103185
5,000	H7	5	86	23	28	58	54	6	30103024
5,010	+0,004	5	86	23	28	58	54	6	30103189
5,020	+0,004	5	86	23	28	58	54	6	30103191
5,100	H7	5	86	23	28	58	54	6	30103026
5,200	H7	5	86	23	28	58	54	6	30103028
5,300	H7	5	86	23	28	58	54	6	30103030
5,400	H7	6	93	26	36	57	53	6	30103032
5,500	H7	6	93	26	36	57	53	6	30103034
5,600	H7	6	93	26	36	57	53	6	30103036
5,700	H7	6	93	26	36	57	53	6	30103038
5,800	H7	6	93	26	36	57	53	6	30103040
5,900	H7	6	93	26	36	57	53	6	30103042
5,970	+0,005	6	93	26	36	57	53	6	30103193
5,980	+0,005	6	93	26	36	57	53	6	30103195
5,990	+0,005	6	93	26	36	57	53	6	30103197
6,000	H7	6	93	26	36	57	53	6	30103044
6,010*	+0,005	6	93	26	36	57	53	6	30103201
6,020*	+0,005	6	93	26	36	57	53	6	30103203
6,100	H7	6	101	28	36	65	61	6	30103046
6,200	H7	6	101	28	36	65	61	6	30103048
6,300	H7	6	101	28	36	65	61	6	30103050
6,400	H7	6	101	28	36	65	61	6	30103052
6,500	H7	6	101	28	36	65	61	6	30103054
6,600	H7	6	101	28	36	65	61	6	30103056
6,700	H7	6	101	28	36	65	61	6	30103058
6,800	H7	8	109	31	36	73	69	6	30103060
6,900	H7	8	109	31	36	73	69	6	30103062

Continued on next page.

NC machine reamer I B030505, fixed design according to DIN 212-3B

Dimensions								z	Order no.
d ₁	Tolerance	d ₂ h6	l ₁	l ₂	l ₃	l ₄	l ₅		
7,000	H7	8	109	31	36	73	69	6	30103064
7,100	H7	8	109	31	36	73	69	6	30103066
7,200	H7	8	109	31	36	73	69	6	30103068
7,300	H7	8	109	31	36	73	69	6	30103070
7,400	H7	8	109	31	36	73	69	6	30103072
7,500	H7	8	109	31	36	73	69	6	30103074
7,600	H7	8	117	33	36	81	77	6	30103076
7,700	H7	8	117	33	36	81	77	6	30103078
7,800	H7	8	117	33	36	81	77	6	30103080
7,900	H7	8	117	33	36	81	77	6	30103082
7,970	+0,005	8	117	33	36	81	77	6	30103205
7,980	+0,005	8	117	33	36	81	77	6	30103207
7,990	+0,005	8	117	33	36	81	77	6	30103209
8,000	H7	8	117	33	36	81	77	6	30103084
8,010	+0,005	8	117	33	36	81	77	6	30103213
8,020	+0,005	8	117	33	36	81	77	6	30103215
8,100	H7	8	117	33	36	81	77	6	30103086
8,200	H7	8	117	33	36	81	77	6	30103088
8,300	H7	8	117	33	36	81	77	6	30103090
8,400	H7	8	117	33	36	81	77	6	30103092
8,500	H7	8	117	33	36	81	77	6	30103094
8,600	H7	10	125	36	40	85	81	6	30103096
8,700	H7	10	125	36	40	85	81	6	30103098
8,800	H7	10	125	36	40	85	81	6	30103100
8,900	H7	10	125	36	40	85	81	6	30103102
9,000	H7	10	125	36	40	85	81	6	30103104
9,010	+0,005	10	125	36	40	85	81	6	30103219
9,020	+0,005	10	125	36	40	85	81	6	30103221
9,100	H7	10	125	36	40	85	81	6	30103106
9,200	H7	10	125	36	40	85	81	6	30103108
9,300	H7	10	125	36	40	85	81	6	30103110
9,400	H7	10	125	36	40	85	81	6	30103112
9,500	H7	10	125	36	40	85	81	6	30103114
9,600	H7	10	133	38	40	93	89	6	30103116
9,700	H7	10	133	38	40	93	89	6	30103118
9,800	H7	10	133	38	40	93	89	6	30103120
9,900	H7	10	133	38	40	93	89	6	30103122
9,970	+0,005	10	133	38	40	93	89	6	30103223
9,980	+0,005	10	133	38	40	93	89	6	30103225
9,990	+0,005	10	133	38	40	93	89	6	30103227
10,000	H7	10	133	38	40	93	89	6	30103124
10,010	+0,005	10	133	38	40	93	89	6	30103231
10,020	+0,005	10	133	38	40	93	89	6	30103233
10,500	H7	10	133	38	40	93	89	6	30310463
11,000	H7	10	142	41	40	102	98	6	30103126
11,500	H7	10	142	41	40	102	98	6	30310464
11,970	+0,005	10	151	44	40	111	106	6	30103235
11,980	+0,005	10	151	44	40	111	106	6	30103237
11,990	+0,005	10	151	44	40	111	106	6	30103239
12,000	H7	10	151	44	40	111	106	6	30103128
13,000	H7	10	151	44	40	111	106	6	30103130
14,000	H7	14	160	47	45	115	110	8	30103132
15,000	H7	14	162	50	45	117	112	8	30103134
16,000	H7	14	170	52	45	125	120	8	30103136
17,000	H7	14	175	54	45	130	125	8	30103138
18,000	H7	14	182	56	45	137	132	8	30103140
19,000	H7	16	189	58	48	141	136	8	30103142
20,000	H7	16	195	60	48	147	142	8	30103144

Configurable features



Bore diameter tolerance \geq IT6:
 - Diameter in increments of 0.001 mm freely selectable
 - Can be ordered in tolerance \geq IT6



Specification:
 B030505[Diameter][Tolerance]

G variant (see page 303):
 - Diameter in increments of 0.001 mm freely selectable
 - Can be ordered from tolerances \geq 4 μ m

G variant specification:
 B030505[Diameter][Tolerance]

IT6 tolerance example:
 B030505- \emptyset 16.350H6

Bore diameter $d_1 = 16.350$ H6

G variant example:
 B030505- \emptyset 16.350-4

Special tool diameter $d_1 = 16.350 - 4$ μ m

Dimensions of configurable series IT6

d_1	d_2 h6	l_1	l_2	l_3	l_4	l_5	z
0,950-1,060 ⁽¹⁾	1	34	5,5	19	15	12,5	3
1,061-1,180 ⁽¹⁾	1	36	6,5	20,5	15,5	13	3
1,181-1,320 ⁽¹⁾	2	38	7,5	21,5	16,5	14	3
1,321-1,500 ⁽¹⁾	2	40	8	22	18	15,5	3
1,501-1,700 ⁽¹⁾	2	43	9	23	20	16	3
1,701-1,900 ⁽¹⁾	2	46	10	24	22	19	4
1,901-2,120 ⁽¹⁾	2	49	11	25	24	21	4
2,121-2,360 ⁽¹⁾	3	53	12	28	25	22	4
2,361-2,650 ⁽¹⁾	3	57	14	28	29	26	4
2,651-3,030 ⁽²⁾	3	61	15	28	33	30	6
3,031-3,350	4	65	16	28	37	34	6
3,351-3,750	4	70	18	28	42	39	6
3,751-4,250	4	75	19	28	47	44	6
4,251-4,750	5	80	21	28	52	48	6
4,751-5,300	5	86	23	28	58	54	6
5,301-5,600	6	93	26	36	57	53	6
5,601-6,030 ⁽²⁾	6	93	26	36	57	53	6
6,031-6,700	6	101	28	36	65	61	6
6,701-7,500	8	109	31	36	73	69	6
7,501-8,500	8	117	33	36	81	77	6
8,501-9,500	10	125	36	40	85	81	6
9,501-10,600	10	133	38	40	93	89	6
10,601-11,800	10	142	41	40	102	98	6
11,801-13,200	10	151	44	40	111	106	6
13,201-14,000	14	160	47	45	115	110	8
14,001-15,000	14	162	50	45	117	112	8
15,001-16,000	14	170	52	45	125	120	8
16,001-17,000	14	175	54	45	130	125	8
17,001-18,000	14	182	56	45	137	132	8
18,001-19,000	16	189	58	48	141	136	8
19,001-20,000	16	195	60	48	147	142	8

(1) $\leq d_1$ 3.000 mm only IT7 possible.

(2) Minimal deviation from the standard for manufacturing reasons.

Dimensions in mm.

For cutting data recommendations, see end of chapter.

Special designs and possible coatings available upon request.

* Minimal deviation from the standard for manufacturing reasons.

NC machine reamer set I B030507

10-piece set with straight shank diameters suitable for connection in hydraulic chucks, high-precision chucks and shrink chucks

Design:

Diameter: 1.000 - 12.000 mm
 Cutting direction: Right-hand cutting
 Cutting material: HSS-E, uncoated (SU344)
 Groove direction: Spiral fluted

Special feature:

Ø 1 - 3 mm: Design with centre points on both sides.
 Ø 4 - 12 mm: Design with internal centre.

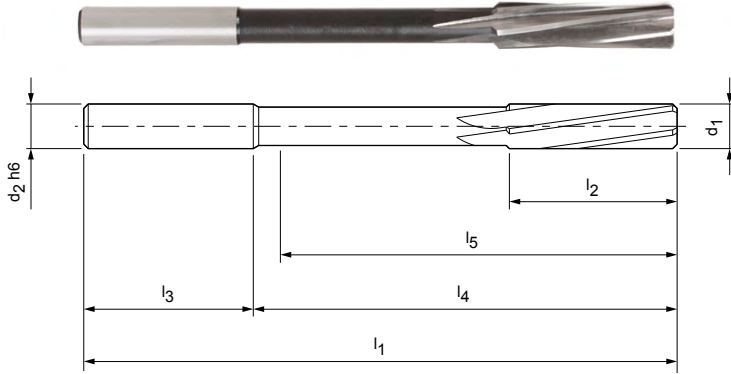

Preferred series in H7

Dimensions							z	Order no.
d ₁ H7	d ₂ h6	l ₁	l ₂	l ₃	l ₄	l ₅		
1,500	2	40	8	22	18	15,5	3	30134724
2,000	2	49	11	25	24	21	4	
3,000	3	61	15	28	33	30	6	
4,000	4	75	19	28	47	44	6	
5,000	5	86	23	28	58	54	6	
6,000	6	93	26	36	57	53	6	
7,000	8	109	31	36	73	69	6	
8,000	8	117	33	36	81	77	6	
10,000	10	133	38	40	93	89	6	
12,000	10	151	44	40	111	106	6	

Dimensions in mm.

For cutting data recommendations, see end of chapter.

Special designs and possible coatings available upon request.

Notes

Machine reamer | B030510

Fixed design

Design:

Diameter: 0.950 - 20.000 mm
 Cutting direction: Right-hand cutting
 Cutting material: HSS-E, uncoated (SU344)
 Groove direction: Straight fluted

Special feature:

ø 1 - 3.5 mm: Design with centre points on both sides.
 ø 4 - 20 mm: Design with internal centre.

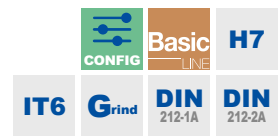
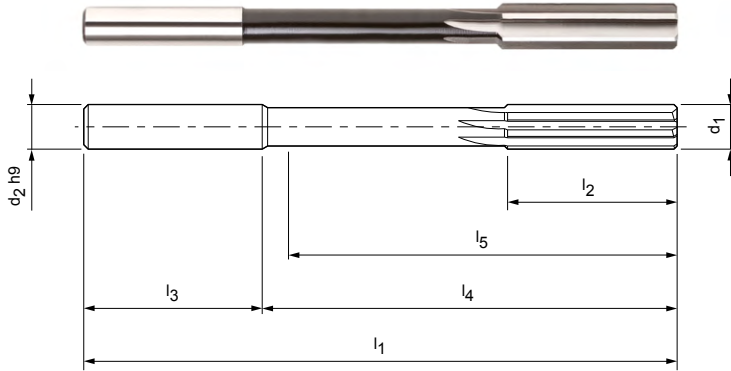

Preferred series in H7

Dimensions							z	Order no.
d_1 H7	d_2 h9	l_1	l_2	l_3	l_4	l_5		
1,000	1	34	5,5	19	15	12,5	3	30103244
1,100	1,1	36	6,5	20,5	15,5	13	3	30103245
1,200	1,2	38	7,5	21,5	16,5	14	3	30103246
1,400	1,4	40	8	22	18	15,5	3	30103248
1,500	1,5	40	8	22	18	15,5	3	30103249
1,600	1,6	43	9	23	20	17,5	3	30103250
1,800	1,8	46	10	24	22	19	4	30103252
2,000	2	49	11	25	24	21	4	30103254
2,200	2,2	53	12	28	25	22	4	30103256
2,500	2,5	57	14	28	29	26	4	30103259
3,000	3	61	15	28	33	30	6	30103264
3,200	3,2	65	16	28	37	34	6	30103266
3,500	3,5	70	18	28	42	39	6	30103269
4,000	4	75	19	28	47	44	6	30103277
4,500	4,5	80	21	28	52	48	6	30103287
5,000	5	86	23	28	58	54	6	30103297
5,500	5,6	93	26	36	57	53	6	30103307
6,000	5,6	93	26	36	57	53	6	30103317
6,500	6,3	101	28	36	65	61	6	30103327
7,000	7,1	109	31	36	73	69	6	30103337
7,500	7,1	109	31	36	73	69	6	30103347
8,000	8	117	33	36	81	77	6	30103357
8,500	8	117	33	36	81	77	6	30103367
9,000	9	125	36	40	85	81	6	30103377
9,500	9	125	36	40	85	81	6	30103385
10,000	10	133	38	40	93	89	6	30103395
10,500	10	133	38	40	93	89	6	30103405
11,000	10	142	41	40	102	98	6	30103411
11,500	10	142	41	40	102	98	6	30103417
12,000	10	151	44	40	111	106	6	30103427
13,000	10	151	44	40	111	106	6	30103429
14,000	12,5	160	47	45	115	110	8	30103431
15,000	12,5	162	50	45	117	112	8	30103433
16,000	12,5	170	52	45	125	120	8	30103435
17,000	14	175	54	45	130	125	8	30103437

Machine reamer I B030510, fixed design

Dimensions							z	Order no.
d ₁ H7	d ₂ h9	l ₁	l ₂	l ₃	l ₄	l ₅		
18,000	14	182	56	45	137	132	8	30103439
19,000	16	189	58	48	141	136	8	30103441
20,000	16	195	60	48	147	142	8	30103443

Configurable features



Bore diameter tolerance ≥ IT6:
 - Diameter in increments of 0.001 mm freely selectable
 - Can be ordered in tolerance ≥ IT6



Specification:
 B030510[Diameter][Tolerance]

G variant (see page 303):
 - Diameter in increments of 0.001 mm freely selectable
 - Can be ordered from tolerances ≥ 4 μm

G variant specification:
 B030510[Diameter][Tolerance]

IT6 tolerance example:
 B030510-Ø16.350H6

Bore diameter d₁ = 16.350 H6

G variant example:
 B030510-Ø16.350-4

Special tool diameter d₁ = 16.350 -4 μm

Dimensions of configurable series IT6

d ₁	d ₂ h9	l ₁	l ₂	l ₃	l ₄	l ₅	z
0,950-1,060 ⁽¹⁾	1	34	5,5	19	15	12,5	3
1,061-1,180 ⁽¹⁾	1,1	36	6,5	20,5	15,5	13	3
1,181-1,320 ⁽¹⁾	1,2	38	7,5	21,5	16,5	14	3
1,321-1,410 ⁽¹⁾	1,4	40	8	22	18	15,5	3
1,411-1,500 ⁽¹⁾	1,5	40	8	22	18	15,5	3
1,501-1,700 ⁽¹⁾	1,6	43	9	23	20	17,5	3
1,701-1,900 ⁽¹⁾	1,8	46	10	24	22	19	4
1,901-2,120 ⁽¹⁾	2	49	11	25	24	21	4
2,121-2,360 ⁽¹⁾	2,2	53	12	28	25	22	4
2,361-2,650 ⁽¹⁾	2,5	57	14	28	29	26	4
2,651-3,030 ⁽²⁾	3	61	15	28	33	30	6
3,031-3,350	3,2	65	16	28	37	34	6
3,351-3,750	3,5	70	18	28	42	39	6
3,751-4,250	4	75	19	28	47	44	6
4,251-4,750	4,5	80	21	28	52	48	6
4,751-5,300	5	86	23	28	58	54	6
5,301-5,600	5,6	93	26	36	57	53	6
5,601-6,030 ⁽²⁾	5,6	93	26	36	57	53	6
6,031-6,700	6,3	101	28	36	65	61	6
6,701-7,200	7,1	109	31	36	73	69	6
7,201-7,500	7,1	109	31	36	73	69	6
7,501-8,200	8	117	33	36	81	77	6
8,201-8,500	8	117	33	36	81	77	6
8,501-9,200	9	125	36	40	85	81	6
9,201-9,500	9	125	36	40	85	81	6
9,501-10,200	10	133	38	40	93	89	6
10,201-10,600	10	133	38	40	93	89	6
10,601-11,200	10	142	41	40	102	98	6
11,201-11,800	10	142	41	40	102	98	6
11,801-12,200	10	151	44	40	111	106	6
12,201-13,200	10	151	44	40	111	106	6
13,201-14,000	12,5	160	47	45	115	110	8
14,001-15,000	12,5	162	50	45	117	112	8
15,001-16,000	12,5	170	52	45	125	120	8
16,001-17,000	14	175	54	45	130	125	8
17,001-18,000	14	182	56	45	137	132	8
18,001-19,000	16	189	58	48	141	136	8
19,001-20,000	16	195	60	48	147	142	8

(1) ≤ d₁ 3.000 mm only IT7 possible.

(2) Minimal deviation from the standard for manufacturing reasons.

Dimensions in mm.

For cutting data recommendations, see end of chapter.

Special designs and possible coatings available upon request.

Machine reamer | B030511

Fixed design

Design:

Diameter: 0.950 - 20.000 mm
 Cutting direction: Right-hand cutting
 Cutting material: HSS-E, uncoated (SU344)
 Groove direction: Spiral fluted

Special feature:

ø 1 - 3.7 mm: Design with centre points on both sides.
 ø 4 - 20 mm: Design with internal centre.

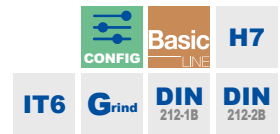
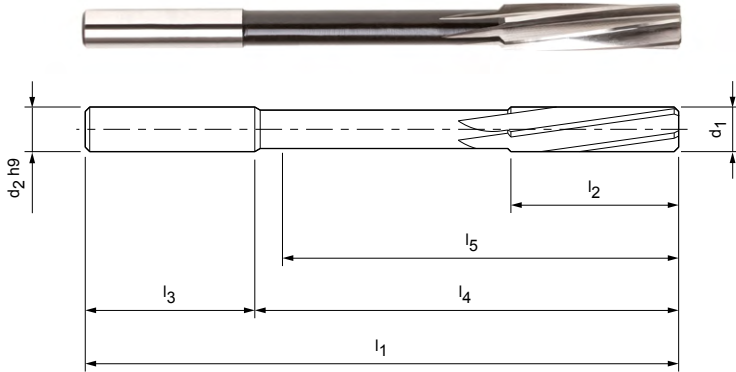

Preferred series in H7

Dimensions							z	Order no.
d ₁ H7	d ₂ h9	l ₁	l ₂	l ₃	l ₄	l ₅		
1,000	1	34	5,5	19	15	12,5	3	30103444
1,100	1,1	36	6,5	20,5	15,5	13	3	30103445
1,200	1,2	38	7,5	21,5	16,5	14	3	30103446
1,300	1,2	38	7,5	21,5	16,5	14	3	30103447
1,400	1,4	40	8	22	18	15,5	3	30103448
1,500	1,5	40	8	22	18	15,5	3	30103449
1,600	1,6	43	9	23	20	17,5	3	30103450
1,700	1,6	43	9	23	20	17,5	3	30103451
1,800	1,8	46	10	24	22	19	4	30103452
1,900	1,8	46	10	24	22	19	4	30103453
2,000	2	49	11	25	24	21	4	30103454
2,100	2	49	11	25	24	21	4	30103455
2,200	2,2	53	12	28	25	22	4	30103456
2,300	2,2	53	12	28	25	22	4	30103457
2,400	2,5	57	14	28	29	26	4	30103458
2,500	2,5	57	14	28	29	26	4	30103459
2,600	2,5	57	14	28	29	26	4	30103460
2,700	3	61	15	28	33	30	6	30103461
2,800	3	61	15	28	33	30	6	30103462
2,900	3	61	15	28	33	30	6	30103463
3,000	3	61	15	28	33	30	6	30103464
3,100	3,2	65	16	28	37	34	6	30103465
3,200	3,2	65	16	28	37	34	6	30103466
3,300	3,2	65	16	28	37	34	6	30103467
3,400	3,5	70	18	28	42	39	6	30103468
3,500	3,5	70	18	28	42	39	6	30103469
3,600	3,5	70	18	28	42	39	6	30103470
3,700	3,5	70	18	28	42	39	6	30103471
3,800	4	75	19	28	47	44	6	30103473
3,900	4	75	19	28	47	44	6	30103475
4,000	4	75	19	28	47	44	6	30103477
4,100	4	75	19	28	47	44	6	30103479
4,200	4	75	19	28	47	44	6	30103481
4,300	4,5	80	21	28	52	48	6	30103483
4,400	4,5	80	21	28	52	48	6	30103485

Machine reamer I B030511, fixed design according to DIN 212-2B

Dimensions							z	Order no.
d ₁ H7	d ₂ h9	l ₁	l ₂	l ₃	l ₄	l ₅		
4,500	4,5	80	21	28	52	48	6	30103487
4,600	4,5	80	21	28	52	48	6	30103489
4,700	4,5	80	21	28	52	48	6	30103491
4,800	5	86	23	28	58	54	6	30103493
4,900	5	86	23	28	58	54	6	30103495
5,000	5	86	23	28	58	54	6	30103497
5,100	5	86	23	28	58	54	6	30103499
5,200	5	86	23	28	58	54	6	30103501
5,300	5	86	23	28	58	54	6	30103503
5,400	5,6	93	26	36	57	53	6	30103505
5,500	5,6	93	26	36	57	53	6	30103507
5,600	5,6	93	26	36	57	53	6	30103509
5,700	5,6	93	26	36	57	53	6	30103511
5,800	5,6	93	26	36	57	53	6	30103513
5,900	5,6	93	26	36	57	53	6	30103515
6,000	5,6	93	26	36	57	53	6	30103517
6,100	6,3	101	28	36	65	61	6	30103519
6,200	6,3	101	28	36	65	61	6	30103521
6,300	6,3	101	28	36	65	61	6	30103523
6,400	6,3	101	28	36	65	61	6	30103525
6,500	6,3	101	28	36	65	61	6	30103527
6,600	6,3	101	28	36	65	61	6	30103529
6,700	6,3	101	28	36	65	61	6	30103531
6,800	7,1	109	31	36	73	69	6	30103533
6,900	7,1	109	31	36	73	69	6	30103535
7,000	7,1	109	31	36	73	69	6	30103537
7,100	7,1	109	31	36	73	69	6	30103539
7,200	7,1	109	31	36	73	69	6	30103541
7,300	7,1	109	31	36	73	69	6	30103543
7,400	7,1	109	31	36	73	69	6	30103545
7,500	7,1	109	31	36	73	69	6	30103547
7,600	8	117	33	36	81	77	6	30103549
7,700	8	117	33	36	81	77	6	30103551
7,800	8	117	33	36	81	77	6	30103553
7,900	8	117	33	36	81	77	6	30103555
8,000	8	117	33	36	81	77	6	30103557
8,100	8	117	33	36	81	77	6	30103559
8,200	8	117	33	36	81	77	6	30103561
8,300	8	117	33	36	81	77	6	30103563
8,400	8	117	33	36	81	77	6	30103565
8,500	8	117	33	36	81	77	6	30103567
8,600	9	125	36	40	85	81	6	30103569
8,700	9	125	36	40	85	81	6	30103571
8,800	9	125	36	40	85	81	6	30103573
8,900	9	125	36	40	85	81	6	30103575
9,000	9	125	36	40	85	81	6	30103577
9,100	9	125	36	40	85	81	6	30103579
9,200	9	125	36	40	85	81	6	30103581
9,300	9	125	36	40	85	81	6	30103583
9,400	9	125	36	40	85	81	6	30103585
9,500	9	125	36	40	85	81	6	30103587
9,600	10	133	38	40	93	89	6	30103589
9,700	10	133	38	40	93	89	6	30103591
9,800	10	133	38	40	93	89	6	30103593
9,900	10	133	38	40	93	89	6	30103595
10,000	10	133	38	40	93	89	6	30103597
10,100	10	133	38	40	93	89	6	30103599

Continued on next page.

Machine reamer I B030511, fixed design according to DIN 212-2B

Dimensions							z	Order no.
d ₁ H7	d ₂ h9	l ₁	l ₂	l ₃	l ₄	l ₅		
10,200	10	133	38	40	93	89	6	30103601
10,300	10	133	38	40	93	89	6	30103603
10,400	10	133	38	40	93	89	6	30103605
10,500	10	133	38	40	93	89	6	30103607
10,600	10	133	38	40	93	89	6	30103609
10,700	10	142	41	40	102	98	6	30103611
10,800	10	142	41	40	102	98	6	30103613
10,900	10	142	41	40	102	98	6	30103615
11,000	10	142	41	40	102	98	6	30103617
11,100	10	142	41	40	102	98	6	30103619
11,200	10	142	41	40	102	98	6	30103621
11,300	10	142	41	40	102	98	6	30103623
11,400	10	142	41	40	102	98	6	30103625
11,500	10	142	41	40	102	98	6	30103627
11,600	10	142	41	40	102	98	6	30103629
11,700	10	142	41	40	102	98	6	30103631
11,800	10	142	41	40	102	98	6	30103633
11,900	10	151	44	40	111	106	6	30103635
12,000	10	151	44	40	111	106	6	30103637
13,000	10	151	44	40	111	106	6	30103639
14,000	12,5	160	47	45	115	110	8	30103641
15,000	12,5	162	50	45	117	112	8	30103643
16,000	12,5	170	52	45	125	120	8	30103645
17,000	14	175	54	45	130	125	8	30103647
18,000	14	182	56	45	137	132	8	30103649
19,000	16	189	58	48	141	136	8	30103651
20,000	16	195	60	48	147	142	8	30103653

Configurable features



Bore diameter tolerance \geq IT6:
 - Diameter in increments of 0.001 mm freely selectable
 - Can be ordered in tolerance \geq IT6



Specification:
 B030511[Diameter][Tolerance]

G variant (see page 303):
 - Diameter in increments of 0.001 mm freely selectable
 - Can be ordered from tolerances \geq 4 μ m

G variant specification:
 B030511[Diameter][Tolerance]

IT6 tolerance example:
 B030511-Ø16.350H6

Bore diameter $d_1 = 16.350$ H6

G variant example:
 B030511-Ø16.350-4

Special tool diameter $d_1 = 16.350 - 4$ μ m

Dimensions of configurable series IT6

d_1	d_2 h9	l_1	l_2	l_3	l_4	l_5	z
0,950-1,060 ⁽¹⁾	1	34	5,5	19	15	12,5	3
1,061-1,180 ⁽¹⁾	1,1	36	6,5	20,5	15,5	13	3
1,181-1,320 ⁽¹⁾	1,2	38	7,5	21,5	16,5	14	3
1,321-1,410 ⁽¹⁾	1,4	40	8	22	18	15,5	3
1,411-1,500 ⁽¹⁾	1,5	40	8	22	18	15,5	3
1,501-1,700 ⁽¹⁾	1,6	43	9	23	20	17,5	3
1,701-1,900 ⁽¹⁾	1,8	46	10	24	22	19	4
1,901-2,120 ⁽¹⁾	2	49	11	25	24	21	4
2,121-2,360 ⁽¹⁾	2,2	53	12	28	25	22	4
2,361-2,650 ⁽¹⁾	2,5	57	14	28	29	26	4
2,651-3,030 ⁽²⁾	3	61	15	28	33	30	6
3,031-3,350	3,2	65	16	28	37	34	6
3,351-3,750	3,5	70	18	28	42	39	6
3,751-4,250	4	75	19	28	47	44	6
4,251-4,750	4,5	80	21	28	52	48	6
4,751-5,300	5	86	23	28	58	54	6
5,301-5,600	5,6	93	26	36	57	53	6
5,601-6,030 ⁽²⁾	5,6	93	26	36	57	53	6
6,031-6,700	6,3	101	28	36	65	61	6
6,701-7,200	7,1	109	31	36	73	69	6
7,201-7,500	7,1	109	31	36	73	69	6
7,501-8,200	8	117	33	36	81	77	6
8,201-8,500	8	117	33	36	81	77	6
8,501-9,200	9	125	36	40	85	81	6
9,201-9,500	9	125	36	40	85	81	6
9,501-10,200	10	133	38	40	93	89	6
10,201-10,600	10	133	38	40	93	89	6
10,601-11,200	10	142	41	40	102	98	6
11,201-11,800	10	142	41	40	102	98	6
11,801-12,200	10	151	44	40	111	106	6
12,201-13,200	10	151	44	40	111	106	6
13,201-14,000	12,5	160	47	45	115	110	8
14,001-15,000	12,5	162	50	45	117	112	8
15,001-16,000	12,5	170	52	45	125	120	8
16,001-17,000	14	175	54	45	130	125	8
17,001-18,000	14	182	56	45	137	132	8
18,001-19,000	16	189	58	48	141	136	8
19,001-20,000	16	195	60	48	147	142	8

(1) $\leq d_1$ 3.000 mm only IT7 possible.

(2) Minimal deviation from the standard for manufacturing reasons.

Dimensions in mm.

For cutting data recommendations, see end of chapter.

Special designs and possible coatings available upon request.

Machine reamer | B033511

Fixed design

Design:

Diameter:

3.751 - 20.000 mm

Cutting direction:

Right-hand cutting

Cutting material:

HSS-E, TiN-coated (SP344)

Groove direction:

Spiral fluted

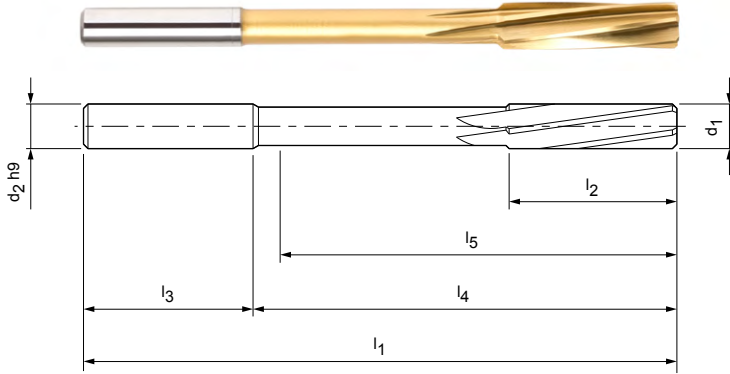

Preferred series in H7

Dimensions							z	Order no.
$d_1 H7$	$d_2 h9$	l_1	l_2	l_3	l_4	l_5		
4,000	4	75	19	28	47	44	6	30107951
5,000	5	86	23	28	58	54	6	30107953
6,000	5,6	93	26	36	57	53	6	30107956
7,000	7,1	109	31	36	73	69	6	30107958
8,000	8	117	33	36	81	77	6	30107960
9,000	9	125	36	40	85	81	6	30107962
10,000	10	133	38	40	93	89	6	30107964
11,000	10	142	41	40	102	98	6	30107966
12,000	10	151	44	40	111	106	6	30107968
13,000	10	151	44	40	111	106	6	30107970
14,000	12,5	160	47	45	115	110	8	30107972
15,000	12,5	162	50	45	117	112	8	30107974
16,000	12,5	170	52	45	125	120	8	30107976
17,000	14	175	54	45	130	125	8	30107978
18,000	14	182	56	45	137	132	8	30107980
19,000	16	189	58	48	141	136	8	30107982
20,000	16	195	60	48	147	142	8	30107984

Configurable features



Bore diameter tolerance \geq IT6:
 - Diameter in increments of 0.001 mm freely selectable
 - Can be ordered in tolerance \geq IT6



Specification:
 B033511[**Diameter**][**Tolerance**]

G variant (see page 303):
 - Diameter in increments of 0.001 mm freely selectable
 - Can be ordered from tolerances $\geq 4 \mu\text{m}$

G variant specification:
 B033511[**Diameter**][**Tolerance**]

IT6 tolerance example:
 B033511-**Ø16.350H6**

Bore diameter $d_1 = 16.350 \text{ H6}$

G variant example:
 B033511-**Ø16.350-4**

Special tool diameter $d_1 = 16.350 -4 \mu\text{m}$

Dimensions of configurable series IT6

d_1	$d_2 \text{ h9}$	l_1	l_2	l_3	l_4	l_5	z
3,751-4,250	4	75	19	28	47	44	6
4,251-4,750	4,5	80	21	28	52	48	6
4,751-5,300	5	86	23	28	58	54	6
5,301-5,600	5,6	93	26	36	57	53	6
5,601-6,030 ⁽¹⁾	5,6	93	26	36	57	53	6
6,031-6,700	6,3	101	28	36	65	61	6
6,701-7,200	7,1	109	31	36	73	69	6
7,201-7,500	7,1	109	31	36	73	69	6
7,501-8,200	8	117	33	36	81	77	6
8,201-8,500	8	117	33	36	81	77	6
8,501-9,200	9	125	36	40	85	81	6
9,201-9,500	9	125	36	40	85	81	6
9,501-10,200	10	133	38	40	93	89	6
10,201-10,600	10	133	38	40	93	89	6
10,601-11,200	10	142	41	40	102	98	6
11,201-11,800	10	142	41	40	102	98	6
11,801-12,200	10	151	44	40	111	106	6
12,201-13,200	10	151	44	40	111	106	6
13,201-14,000	12,5	160	47	45	115	110	8
14,001-15,000	12,5	162	50	45	117	112	8
15,001-16,000	12,5	170	52	45	125	120	8
16,001-17,000	14	175	54	45	130	125	8
17,001-18,000	14	182	56	45	137	132	8
18,001-19,000	16	189	58	48	141	136	8
19,001-20,000	16	195	60	48	147	142	8

(1) Minimal deviation from the standard for manufacturing reasons.

Dimensions in mm.

For cutting data recommendations, see end of chapter.

Special designs and possible coatings available upon request.

Machine reamer | B030513

Fixed design

Design:

Diameter: 0.950 - 12.050 mm
 Cutting direction: Right-hand cutting
 Cutting material: HSS-E, uncoated (SU344)
 Groove direction: Spiral fluted

Special feature:

ø 0.95 - 3.75 mm: Design with centre points on both sides.
 ø 3.76 - 12.05 mm: Design with internal centre.

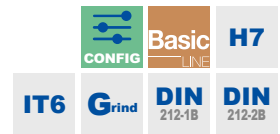
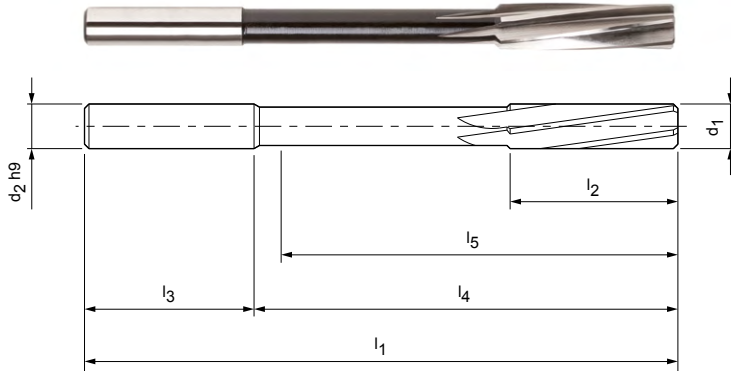

Preferred series available from stock +0.004 mm | +0.005 mm

Dimensions								z	Order no.
d ₁	Tolerance	d ₂ h9	l ₁	l ₂	l ₃	l ₄	l ₅		
0,950	+0,004	1	34	5,5	19	15	12,5	3	30103654
0,960	+0,004	1	34	5,5	19	15	12,5	3	30103655
0,970	+0,004	1	34	5,5	19	15	12,5	3	30103656
0,980	+0,004	1	34	5,5	19	15	12,5	3	30103657
0,990	+0,004	1	34	5,5	19	15	12,5	3	30103658
1,000	+0,004	1	34	5,5	19	15	12,5	3	30103659
1,010	+0,004	1	34	5,5	19	15	12,5	3	30103660
1,020	+0,004	1	34	5,5	19	15	12,5	3	30103661
1,030	+0,004	1	34	5,5	19	15	12,5	3	30103662
1,040	+0,004	1	34	5,5	19	15	12,5	3	30103663
1,050	+0,004	1	34	5,5	19	15	12,5	3	30103664
1,060	+0,004	1	34	5,5	19	15	12,5	3	30103665
1,070	+0,004	1,1	36	6,5	20,5	15,5	13	3	30103666
1,080	+0,004	1,1	36	6,5	20,5	15,5	13	3	30103667
1,090	+0,004	1,1	36	6,5	20,5	15,5	13	3	30103668
1,100	+0,004	1,1	36	6,5	20,5	15,5	13	3	30103669
1,110	+0,004	1,1	36	6,5	20,5	15,5	13	3	30103670
1,120	+0,004	1,1	36	6,5	20,5	15,5	13	3	30103671
1,130	+0,004	1,1	36	6,5	20,5	15,5	13	3	30103672
1,140	+0,004	1,1	36	6,5	20,5	15,5	13	3	30103673
1,150	+0,004	1,1	36	6,5	20,5	15,5	13	3	30103674
1,160	+0,004	1,1	36	6,5	20,5	15,5	13	3	30103675
1,170	+0,004	1,1	36	6,5	20,5	15,5	13	3	30103676
1,180	+0,004	1,1	36	6,5	20,5	15,5	13	3	30103677
1,190	+0,004	1,2	38	7,5	21,5	16,5	14	3	30103678
1,200	+0,004	1,2	38	7,5	21,5	16,5	14	3	30103679
1,210	+0,004	1,2	38	7,5	21,5	16,5	14	3	30103680
1,220	+0,004	1,2	38	7,5	21,5	16,5	14	3	30103681
1,230	+0,004	1,2	38	7,5	21,5	16,5	14	3	30103682
1,240	+0,004	1,2	38	7,5	21,5	16,5	14	3	30103683
1,250	+0,004	1,2	38	7,5	21,5	16,5	14	3	30103684
1,260	+0,004	1,2	38	7,5	21,5	16,5	14	3	30103685
1,270	+0,004	1,2	38	7,5	21,5	16,5	14	3	30103686
1,280	+0,004	1,2	38	7,5	21,5	16,5	14	3	30103687
1,290	+0,004	1,2	38	7,5	21,5	16,5	14	3	30103688

Machine reamer I B030513, fixed design according to DIN 212-1, Form B ($\varnothing \leq 3.75$ mm) or DIN 212-2, Form B ($\varnothing \geq 3.76$ mm)

Dimensions								z	Order no.
d ₁	Tolerance	d ₂ h9	l ₁	l ₂	l ₃	l ₄	l ₅		
1,300	+0,004	1,2	38	7,5	21,5	16,5	14	3	30103689
1,310	+0,004	1,2	38	7,5	21,5	16,5	14	3	30103690
1,320	+0,004	1,2	38	7,5	21,5	16,5	14	3	30103691
1,330	+0,004	1,4	40	8	22	18	15,5	3	30103692
1,340	+0,004	1,4	40	8	22	18	15,5	3	30103693
1,350	+0,004	1,4	40	8	22	18	15,5	3	30103694
1,360	+0,004	1,4	40	8	22	18	15,5	3	30103695
1,370	+0,004	1,4	40	8	22	18	15,5	3	30103696
1,380	+0,004	1,4	40	8	22	18	15,5	3	30103697
1,390	+0,004	1,4	40	8	22	18	15,5	3	30103698
1,400	+0,004	1,4	40	8	22	18	15,5	3	30103699
1,410	+0,004	1,4	40	8	22	18	15,5	3	30103700
1,420	+0,004	1,5	40	8	22	18	15,5	3	30103701
1,430	+0,004	1,5	40	8	22	18	15,5	3	30103702
1,440	+0,004	1,5	40	8	22	18	15,5	3	30103703
1,450	+0,004	1,5	40	8	22	18	15,5	3	30103704
1,460	+0,004	1,5	40	8	22	18	15,5	3	30103705
1,470	+0,004	1,5	40	8	22	18	15,5	3	30103706
1,480	+0,004	1,5	40	8	22	18	15,5	3	30103707
1,490	+0,004	1,5	40	8	22	18	15,5	3	30103708
1,500	+0,004	1,5	40	8	22	18	15,5	3	30103709
1,510	+0,004	1,6	43	9	23	20	17,5	3	30103710
1,520	+0,004	1,6	43	9	23	20	17,5	3	30103711
1,530	+0,004	1,6	43	9	23	20	17,5	3	30103712
1,540	+0,004	1,6	43	9	23	20	17,5	3	30103713
1,550	+0,004	1,6	43	9	23	20	17,5	3	30103714
1,560	+0,004	1,6	43	9	23	20	17,5	3	30103715
1,570	+0,004	1,6	43	9	23	20	17,5	3	30103716
1,580	+0,004	1,6	43	9	23	20	17,5	3	30103717
1,590	+0,004	1,6	43	9	23	20	17,5	3	30103718
1,600	+0,004	1,6	43	9	23	20	17,5	3	30103719
1,610	+0,004	1,6	43	9	23	20	17,5	3	30103720
1,620	+0,004	1,6	43	9	23	20	17,5	3	30103721
1,630	+0,004	1,6	43	9	23	20	17,5	3	30103722
1,640	+0,004	1,6	43	9	23	20	17,5	3	30103723
1,650	+0,004	1,6	43	9	23	20	17,5	3	30103724
1,660	+0,004	1,6	43	9	23	20	17,5	3	30103725
1,670	+0,004	1,6	43	9	23	20	17,5	3	30103726
1,680	+0,004	1,6	43	9	23	20	17,5	3	30103727
1,690	+0,004	1,6	43	9	23	20	17,5	3	30103728
1,700	+0,004	1,6	43	9	23	20	17,5	3	30103729
1,710	+0,004	1,8	46	10	24	22	19	4	30103730
1,720	+0,004	1,8	46	10	24	22	19	4	30103731
1,730	+0,004	1,8	46	10	24	22	19	4	30103732
1,740	+0,004	1,8	46	10	24	22	19	4	30103733
1,750	+0,004	1,8	46	10	24	22	19	4	30103734
1,760	+0,004	1,8	46	10	24	22	19	4	30103735
1,770	+0,004	1,8	46	10	24	22	19	4	30103736
1,780	+0,004	1,8	46	10	24	22	19	4	30103737
1,790	+0,004	1,8	46	10	24	22	19	4	30103738
1,800	+0,004	1,8	46	10	24	22	19	4	30103739
1,810	+0,004	1,8	46	10	24	22	19	4	30103740
1,820	+0,004	1,8	46	10	24	22	19	4	30103741
1,830	+0,004	1,8	46	10	24	22	19	4	30103742
1,840	+0,004	1,8	46	10	24	22	19	4	30103743
1,850	+0,004	1,8	46	10	24	22	19	4	30103744
1,860	+0,004	1,8	46	10	24	22	19	4	30103745

Continued on next page.

Machine reamer I B030513, fixed design according to DIN 212-1, Form B ($\varnothing \leq 3.75$ mm) or DIN 212-2, Form B ($\varnothing \geq 3.76$ mm)

Dimensions								z	Order no.
d ₁	Tolerance	d ₂ h9	l ₁	l ₂	l ₃	l ₄	l ₅		
1,870	+0,004	1,8	46	10	24	22	19	4	30103746
1,880	+0,004	1,8	46	10	24	22	19	4	30103747
1,890	+0,004	1,8	46	10	24	22	19	4	30103748
1,900	+0,004	1,8	46	10	24	22	19	4	30103749
1,910	+0,004	2	49	11	25	24	21	4	30103750
1,920	+0,004	2	49	11	25	24	21	4	30103751
1,930	+0,004	2	49	11	25	24	21	4	30103752
1,940	+0,004	2	49	11	25	24	21	4	30103753
1,950	+0,004	2	49	11	25	24	21	4	30103754
1,960	+0,004	2	49	11	25	24	21	4	30103755
1,970	+0,004	2	49	11	25	24	21	4	30103756
1,980	+0,004	2	49	11	25	24	21	4	30103757
1,990	+0,004	2	49	11	25	24	21	4	30103758
2,000	+0,004	2	49	11	25	24	21	4	30103759
2,010	+0,004	2	49	11	25	24	21	4	30103760
2,020	+0,004	2	49	11	25	24	21	4	30103761
2,030	+0,004	2	49	11	25	24	21	4	30103762
2,040	+0,004	2	49	11	25	24	21	4	30103763
2,050	+0,004	2	49	11	25	24	21	4	30103764
2,060	+0,004	2	49	11	25	24	21	4	30103765
2,070	+0,004	2	49	11	25	24	21	4	30103766
2,080	+0,004	2	49	11	25	24	21	4	30103767
2,090	+0,004	2	49	11	25	24	21	4	30103768
2,100	+0,004	2	49	11	25	24	21	4	30103769
2,110	+0,004	2	49	11	25	24	21	4	30103770
2,120	+0,004	2	49	11	25	24	21	4	30103771
2,130	+0,004	2,2	53	12	28	25	22	4	30103772
2,140	+0,004	2,2	53	12	28	25	22	4	30103773
2,150	+0,004	2,2	53	12	28	25	22	4	30103774
2,160	+0,004	2,2	53	12	28	25	22	4	30103775
2,170	+0,004	2,2	53	12	28	25	22	4	30103776
2,180	+0,004	2,2	53	12	28	25	22	4	30103777
2,190	+0,004	2,2	53	12	28	25	22	4	30103778
2,200	+0,004	2,2	53	12	28	25	22	4	30103779
2,210	+0,004	2,2	53	12	28	25	22	4	30103780
2,220	+0,004	2,2	53	12	28	25	22	4	30103781
2,230	+0,004	2,2	53	12	28	25	22	4	30103782
2,240	+0,004	2,2	53	12	28	25	22	4	30103783
2,250	+0,004	2,2	53	12	28	25	22	4	30103784
2,260	+0,004	2,2	53	12	28	25	22	4	30103785
2,270	+0,004	2,2	53	12	28	25	22	4	30103786
2,280	+0,004	2,2	53	12	28	25	22	4	30103787
2,290	+0,004	2,2	53	12	28	25	22	4	30103788
2,300	+0,004	2,2	53	12	28	25	22	4	30103789
2,310	+0,004	2,2	53	12	28	25	22	4	30103790
2,320	+0,004	2,2	53	12	28	25	22	4	30103791
2,330	+0,004	2,2	53	12	28	25	22	4	30103792
2,340	+0,004	2,2	53	12	28	25	22	4	30103793
2,350	+0,004	2,2	53	12	28	25	22	4	30103794
2,360	+0,004	2,2	53	12	28	25	22	4	30103795
2,370	+0,004	2,5	57	14	28	29	26	4	30103796
2,380	+0,004	2,5	57	14	28	29	26	4	30103797
2,390	+0,004	2,5	57	14	28	29	26	4	30103798
2,400	+0,004	2,5	57	14	28	29	26	4	30103799
2,410	+0,004	2,5	57	14	28	29	26	4	30103800
2,420	+0,004	2,5	57	14	28	29	26	4	30103801
2,430	+0,004	2,5	57	14	28	29	26	4	30103802

Machine reamer I B030513, fixed design according to DIN 212-1, Form B ($\varnothing \leq 3.75$ mm) or DIN 212-2, Form B ($\varnothing \geq 3.76$ mm)

Dimensions								z	Order no.
d ₁	Tolerance	d ₂ h9	l ₁	l ₂	l ₃	l ₄	l ₅		
2,440	+0,004	2,5	57	14	28	29	26	4	30103803
2,450	+0,004	2,5	57	14	28	29	26	4	30103804
2,460	+0,004	2,5	57	14	28	29	26	4	30103805
2,470	+0,004	2,5	57	14	28	29	26	4	30103806
2,480	+0,004	2,5	57	14	28	29	26	4	30103807
2,490	+0,004	2,5	57	14	28	29	26	4	30103808
2,500	+0,004	2,5	57	14	28	29	26	4	30103809
2,510	+0,004	2,5	57	14	28	29	26	4	30103810
2,520	+0,004	2,5	57	14	28	29	26	4	30103811
2,530	+0,004	2,5	57	14	28	29	26	4	30103812
2,540	+0,004	2,5	57	14	28	29	26	4	30103813
2,550	+0,004	2,5	57	14	28	29	26	4	30103814
2,560	+0,004	2,5	57	14	28	29	26	4	30103815
2,570	+0,004	2,5	57	14	28	29	26	4	30103816
2,580	+0,004	2,5	57	14	28	29	26	4	30103817
2,590	+0,004	2,5	57	14	28	29	26	4	30103818
2,600	+0,004	2,5	57	14	28	29	26	4	30103819
2,610	+0,004	2,5	57	14	28	29	26	4	30103820
2,620	+0,004	2,5	57	14	28	29	26	4	30103821
2,630	+0,004	2,5	57	14	28	29	26	4	30103822
2,640	+0,004	2,5	57	14	28	29	26	4	30103823
2,650	+0,004	2,5	57	14	28	29	26	4	30103824
2,660	+0,004	3	61	15	28	33	30	6	30103825
2,670	+0,004	3	61	15	28	33	30	6	30103826
2,680	+0,004	3	61	15	28	33	30	6	30103827
2,690	+0,004	3	61	15	28	33	30	6	30103828
2,700	+0,004	3	61	15	28	33	30	6	30103829
2,710	+0,004	3	61	15	28	33	30	6	30103830
2,720	+0,004	3	61	15	28	33	30	6	30103831
2,730	+0,004	3	61	15	28	33	30	6	30103832
2,740	+0,004	3	61	15	28	33	30	6	30103833
2,750	+0,004	3	61	15	28	33	30	6	30103834
2,760	+0,004	3	61	15	28	33	30	6	30103835
2,770	+0,004	3	61	15	28	33	30	6	30103836
2,780	+0,004	3	61	15	28	33	30	6	30103837
2,790	+0,004	3	61	15	28	33	30	6	30103838
2,800	+0,004	3	61	15	28	33	30	6	30103839
2,810	+0,004	3	61	15	28	33	30	6	30103840
2,820	+0,004	3	61	15	28	33	30	6	30103841
2,830	+0,004	3	61	15	28	33	30	6	30103842
2,840	+0,004	3	61	15	28	33	30	6	30103843
2,850	+0,004	3	61	15	28	33	30	6	30103844
2,860	+0,004	3	61	15	28	33	30	6	30103845
2,870	+0,004	3	61	15	28	33	30	6	30103846
2,880	+0,004	3	61	15	28	33	30	6	30103847
2,890	+0,004	3	61	15	28	33	30	6	30103848
2,900	+0,004	3	61	15	28	33	30	6	30103849
2,910	+0,004	3	61	15	28	33	30	6	30103850
2,920	+0,004	3	61	15	28	33	30	6	30103851
2,930	+0,004	3	61	15	28	33	30	6	30103852
2,940	+0,004	3	61	15	28	33	30	6	30103853
2,950	+0,004	3	61	15	28	33	30	6	30103854
2,960	+0,004	3	61	15	28	33	30	6	30103855
2,970	+0,004	3	61	15	28	33	30	6	30103856
2,980	+0,004	3	61	15	28	33	30	6	30103857
2,990	+0,004	3	61	15	28	33	30	6	30103858
3,000	+0,004	3	61	15	28	33	30	6	30103859

Continued on next page.

Machine reamer I B030513, fixed design according to DIN 212-1, Form B ($\varnothing \leq 3.75$ mm) or DIN 212-2, Form B ($\varnothing \geq 3.76$ mm)

Dimensions								z	Order no.
d ₁	Tolerance	d ₂ h9	l ₁	l ₂	l ₃	l ₄	l ₅		
3,010*	+0,004	3	61	15	28	33	30	6	30103860
3,020*	+0,004	3	61	15	28	33	30	6	30103861
3,030*	+0,004	3	61	15	28	33	30	6	30103862
3,040	+0,004	3,2	65	16	28	37	34	6	30103863
3,050	+0,004	3,2	65	16	28	37	34	6	30103864
3,060	+0,004	3,2	65	16	28	37	34	6	30103865
3,070	+0,004	3,2	65	16	28	37	34	6	30103866
3,080	+0,004	3,2	65	16	28	37	34	6	30103867
3,090	+0,004	3,2	65	16	28	37	34	6	30103868
3,100	+0,004	3,2	65	16	28	37	34	6	30103869
3,110	+0,004	3,2	65	16	28	37	34	6	30103870
3,120	+0,004	3,2	65	16	28	37	34	6	30103871
3,130	+0,004	3,2	65	16	28	37	34	6	30103872
3,140	+0,004	3,2	65	16	28	37	34	6	30103873
3,150	+0,004	3,2	65	16	28	37	34	6	30103874
3,160	+0,004	3,2	65	16	28	37	34	6	30103875
3,170	+0,004	3,2	65	16	28	37	34	6	30103876
3,180	+0,004	3,2	65	16	28	37	34	6	30103877
3,190	+0,004	3,2	65	16	28	37	34	6	30103878
3,200	+0,004	3,2	65	16	28	37	34	6	30103879
3,210	+0,004	3,2	65	16	28	37	34	6	30103880
3,220	+0,004	3,2	65	16	28	37	34	6	30103881
3,230	+0,004	3,2	65	16	28	37	34	6	30103882
3,240	+0,004	3,2	65	16	28	37	34	6	30103883
3,250	+0,004	3,2	65	16	28	37	34	6	30103884
3,260	+0,004	3,2	65	16	28	37	34	6	30103885
3,270	+0,004	3,2	65	16	28	37	34	6	30103886
3,280	+0,004	3,2	65	16	28	37	34	6	30103887
3,290	+0,004	3,2	65	16	28	37	34	6	30103888
3,300	+0,004	3,2	65	16	28	37	34	6	30103889
3,310	+0,004	3,2	65	16	28	37	34	6	30103890
3,320	+0,004	3,2	65	16	28	37	34	6	30103891
3,330	+0,004	3,2	65	16	28	37	34	6	30103892
3,340	+0,004	3,2	65	16	28	37	34	6	30103893
3,350	+0,004	3,2	65	16	28	37	34	6	30103894
3,360	+0,004	3,5	70	18	28	42	39	6	30103895
3,370	+0,004	3,5	70	18	28	42	39	6	30103896
3,380	+0,004	3,5	70	18	28	42	39	6	30103897
3,390	+0,004	3,5	70	18	28	42	39	6	30103898
3,400	+0,004	3,5	70	18	28	42	39	6	30103899
3,410	+0,004	3,5	70	18	28	42	39	6	30103900
3,420	+0,004	3,5	70	18	28	42	39	6	30103901
3,430	+0,004	3,5	70	18	28	42	39	6	30103902
3,440	+0,004	3,5	70	18	28	42	39	6	30103903
3,450	+0,004	3,5	70	18	28	42	39	6	30103904
3,460	+0,004	3,5	70	18	28	42	39	6	30103905
3,470	+0,004	3,5	70	18	28	42	39	6	30103906
3,480	+0,004	3,5	70	18	28	42	39	6	30103907
3,490	+0,004	3,5	70	18	28	42	39	6	30103908
3,500	+0,004	3,5	70	18	28	42	39	6	30103909
3,510	+0,004	3,5	70	18	28	42	39	6	30103910
3,520	+0,004	3,5	70	18	28	42	39	6	30103911
3,530	+0,004	3,5	70	18	28	42	39	6	30103912
3,540	+0,004	3,5	70	18	28	42	39	6	30103913
3,550	+0,004	3,5	70	18	28	42	39	6	30103914
3,560	+0,004	3,5	70	18	28	42	39	6	30103915
3,570	+0,004	3,5	70	18	28	42	39	6	30103916

Machine reamer I B030513, fixed design according to DIN 212-1, Form B ($\varnothing \leq 3.75$ mm) or DIN 212-2, Form B ($\varnothing \geq 3.76$ mm)

Dimensions								z	Order no.
d ₁	Tolerance	d ₂ h9	l ₁	l ₂	l ₃	l ₄	l ₅		
3,580	+0,004	3,5	70	18	28	42	39	6	30103917
3,590	+0,004	3,5	70	18	28	42	39	6	30103918
3,600	+0,004	3,5	70	18	28	42	39	6	30103919
3,610	+0,004	3,5	70	18	28	42	39	6	30103920
3,620	+0,004	3,5	70	18	28	42	39	6	30103921
3,630	+0,004	3,5	70	18	28	42	39	6	30103922
3,640	+0,004	3,5	70	18	28	42	39	6	30103923
3,650	+0,004	3,5	70	18	28	42	39	6	30103924
3,660	+0,004	3,5	70	18	28	42	39	6	30103925
3,670	+0,004	3,5	70	18	28	42	39	6	30103926
3,680	+0,004	3,5	70	18	28	42	39	6	30103927
3,690	+0,004	3,5	70	18	28	42	39	6	30103928
3,700	+0,004	3,5	70	18	28	42	39	6	30103929
3,710	+0,004	3,5	70	18	28	42	39	6	30103930
3,720	+0,004	3,5	70	18	28	42	39	6	30103931
3,730	+0,004	3,5	70	18	28	42	39	6	30103932
3,740	+0,004	3,5	70	18	28	42	39	6	30103933
3,750	+0,004	3,5	70	18	28	42	39	6	30103934
3,760	+0,004	4	75	19	28	47	44	6	30103936
3,770	+0,004	4	75	19	28	47	44	6	30103938
3,780	+0,004	4	75	19	28	47	44	6	30103940
3,790	+0,004	4	75	19	28	47	44	6	30103942
3,800	+0,004	4	75	19	28	47	44	6	30103944
3,810	+0,004	4	75	19	28	47	44	6	30103946
3,820	+0,004	4	75	19	28	47	44	6	30103948
3,830	+0,004	4	75	19	28	47	44	6	30103950
3,840	+0,004	4	75	19	28	47	44	6	30103952
3,850	+0,004	4	75	19	28	47	44	6	30103954
3,860	+0,004	4	75	19	28	47	44	6	30103956
3,870	+0,004	4	75	19	28	47	44	6	30103958
3,880	+0,004	4	75	19	28	47	44	6	30103960
3,890	+0,004	4	75	19	28	47	44	6	30103962
3,900	+0,004	4	75	19	28	47	44	6	30103964
3,910	+0,004	4	75	19	28	47	44	6	30103966
3,920	+0,004	4	75	19	28	47	44	6	30103968
3,930	+0,004	4	75	19	28	47	44	6	30103970
3,940	+0,004	4	75	19	28	47	44	6	30103972
3,950	+0,004	4	75	19	28	47	44	6	30103974
3,960	+0,004	4	75	19	28	47	44	6	30103976
3,970	+0,004	4	75	19	28	47	44	6	30103978
3,980	+0,004	4	75	19	28	47	44	6	30103980
3,990	+0,004	4	75	19	28	47	44	6	30103982
4,000	+0,004	4	75	19	28	47	44	6	30103984
4,010	+0,004	4	75	19	28	47	44	6	30103986
4,020	+0,004	4	75	19	28	47	44	6	30103988
4,030	+0,004	4	75	19	28	47	44	6	30103990
4,040	+0,004	4	75	19	28	47	44	6	30103992
4,050	+0,004	4	75	19	28	47	44	6	30103994
4,060	+0,004	4	75	19	28	47	44	6	30103996
4,070	+0,004	4	75	19	28	47	44	6	30103998
4,080	+0,004	4	75	19	28	47	44	6	30104000
4,090	+0,004	4	75	19	28	47	44	6	30104002
4,100	+0,004	4	75	19	28	47	44	6	30104004
4,110	+0,004	4	75	19	28	47	44	6	30104006
4,120	+0,004	4	75	19	28	47	44	6	30104008
4,130	+0,004	4	75	19	28	47	44	6	30104010
4,140	+0,004	4	75	19	28	47	44	6	30104012

Continued on next page.

Machine reamer I B030513, fixed design according to DIN 212-1, Form B ($\varnothing \leq 3.75$ mm) or DIN 212-2, Form B ($\varnothing \geq 3.76$ mm)

Dimensions								z	Order no.
d ₁	Tolerance	d ₂ h9	l ₁	l ₂	l ₃	l ₄	l ₅		
4,150	+0,004	4	75	19	28	47	44	6	30104014
4,160	+0,004	4	75	19	28	47	44	6	30104016
4,170	+0,004	4	75	19	28	47	44	6	30104018
4,180	+0,004	4	75	19	28	47	44	6	30104020
4,190	+0,004	4	75	19	28	47	44	6	30104022
4,200	+0,004	4	75	19	28	47	44	6	30104024
4,210	+0,004	4	75	19	28	47	44	6	30104026
4,220	+0,004	4	75	19	28	47	44	6	30104028
4,230	+0,004	4	75	19	28	47	44	6	30104030
4,240	+0,004	4	75	19	28	47	44	6	30104032
4,250	+0,004	4	75	19	28	47	44	6	30104034
4,260	+0,004	4,5	80	21	28	52	48	6	30104036
4,270	+0,004	4,5	80	21	28	52	48	6	30104038
4,280	+0,004	4,5	80	21	28	52	48	6	30104040
4,290	+0,004	4,5	80	21	28	52	48	6	30104042
4,300	+0,004	4,5	80	21	28	52	48	6	30104044
4,310	+0,004	4,5	80	21	28	52	48	6	30104046
4,320	+0,004	4,5	80	21	28	52	48	6	30104048
4,330	+0,004	4,5	80	21	28	52	48	6	30104050
4,340	+0,004	4,5	80	21	28	52	48	6	30104052
4,350	+0,004	4,5	80	21	28	52	48	6	30104054
4,360	+0,004	4,5	80	21	28	52	48	6	30104056
4,370	+0,004	4,5	80	21	28	52	48	6	30104058
4,380	+0,004	4,5	80	21	28	52	48	6	30104060
4,390	+0,004	4,5	80	21	28	52	48	6	30104062
4,400	+0,004	4,5	80	21	28	52	48	6	30104064
4,410	+0,004	4,5	80	21	28	52	48	6	30104066
4,420	+0,004	4,5	80	21	28	52	48	6	30104068
4,430	+0,004	4,5	80	21	28	52	48	6	30104070
4,440	+0,004	4,5	80	21	28	52	48	6	30104072
4,450	+0,004	4,5	80	21	28	52	48	6	30104074
4,460	+0,004	4,5	80	21	28	52	48	6	30104076
4,470	+0,004	4,5	80	21	28	52	48	6	30104078
4,480	+0,004	4,5	80	21	28	52	48	6	30104080
4,490	+0,004	4,5	80	21	28	52	48	6	30104082
4,500	+0,004	4,5	80	21	28	52	48	6	30104084
4,510	+0,004	4,5	80	21	28	52	48	6	30104086
4,520	+0,004	4,5	80	21	28	52	48	6	30104088
4,530	+0,004	4,5	80	21	28	52	48	6	30104090
4,540	+0,004	4,5	80	21	28	52	48	6	30104092
4,550	+0,004	4,5	80	21	28	52	48	6	30104094
4,560	+0,004	4,5	80	21	28	52	48	6	30104096
4,570	+0,004	4,5	80	21	28	52	48	6	30104098
4,580	+0,004	4,5	80	21	28	52	48	6	30104100
4,590	+0,004	4,5	80	21	28	52	48	6	30104102
4,600	+0,004	4,5	80	21	28	52	48	6	30104104
4,610	+0,004	4,5	80	21	28	52	48	6	30104106
4,620	+0,004	4,5	80	21	28	52	48	6	30104108
4,630	+0,004	4,5	80	21	28	52	48	6	30104110
4,640	+0,004	4,5	80	21	28	52	48	6	30104112
4,650	+0,004	4,5	80	21	28	52	48	6	30104114
4,660	+0,004	4,5	80	21	28	52	48	6	30104116
4,670	+0,004	4,5	80	21	28	52	48	6	30104118
4,680	+0,004	4,5	80	21	28	52	48	6	30104120
4,690	+0,004	4,5	80	21	28	52	48	6	30104122
4,700	+0,004	4,5	80	21	28	52	48	6	30104124
4,710	+0,004	4,5	80	21	28	52	48	6	30104126

Machine reamer I B030513, fixed design according to DIN 212-1, Form B ($\varnothing \leq 3.75$ mm) or DIN 212-2, Form B ($\varnothing \geq 3.76$ mm)

Dimensions								z	Order no.
d ₁	Tolerance	d ₂ h9	l ₁	l ₂	l ₃	l ₄	l ₅		
4,720	+0,004	4,5	80	21	28	52	48	6	30104128
4,730	+0,004	4,5	80	21	28	52	48	6	30104130
4,740	+0,004	4,5	80	21	28	52	48	6	30104132
4,750	+0,004	4,5	80	21	28	52	48	6	30104134
4,760	+0,004	5	86	23	28	58	54	6	30104136
4,770	+0,004	5	86	23	28	58	54	6	30104138
4,780	+0,004	5	86	23	28	58	54	6	30104140
4,790	+0,004	5	86	23	28	58	54	6	30104142
4,800	+0,004	5	86	23	28	58	54	6	30104144
4,810	+0,004	5	86	23	28	58	54	6	30104146
4,820	+0,004	5	86	23	28	58	54	6	30104148
4,830	+0,004	5	86	23	28	58	54	6	30104150
4,840	+0,004	5	86	23	28	58	54	6	30104152
4,850	+0,004	5	86	23	28	58	54	6	30104154
4,860	+0,004	5	86	23	28	58	54	6	30104156
4,870	+0,004	5	86	23	28	58	54	6	30104158
4,880	+0,004	5	86	23	28	58	54	6	30104160
4,890	+0,004	5	86	23	28	58	54	6	30104162
4,900	+0,004	5	86	23	28	58	54	6	30104164
4,910	+0,004	5	86	23	28	58	54	6	30104166
4,920	+0,004	5	86	23	28	58	54	6	30104168
4,930	+0,004	5	86	23	28	58	54	6	30104170
4,940	+0,004	5	86	23	28	58	54	6	30104172
4,950	+0,004	5	86	23	28	58	54	6	30104174
4,960	+0,004	5	86	23	28	58	54	6	30104176
4,970	+0,004	5	86	23	28	58	54	6	30104178
4,980	+0,004	5	86	23	28	58	54	6	30104180
4,990	+0,004	5	86	23	28	58	54	6	30104182
5,000	+0,004	5	86	23	28	58	54	6	30104184
5,010	+0,004	5	86	23	28	58	54	6	30104186
5,020	+0,004	5	86	23	28	58	54	6	30104188
5,030	+0,004	5	86	23	28	58	54	6	30104190
5,040	+0,004	5	86	23	28	58	54	6	30104192
5,050	+0,004	5	86	23	28	58	54	6	30104194
5,060	+0,004	5	86	23	28	58	54	6	30104196
5,070	+0,004	5	86	23	28	58	54	6	30104198
5,080	+0,004	5	86	23	28	58	54	6	30104200
5,090	+0,004	5	86	23	28	58	54	6	30104202
5,100	+0,004	5	86	23	28	58	54	6	30104204
5,110	+0,004	5	86	23	28	58	54	6	30104206
5,120	+0,004	5	86	23	28	58	54	6	30104208
5,130	+0,004	5	86	23	28	58	54	6	30104210
5,140	+0,004	5	86	23	28	58	54	6	30104212
5,150	+0,004	5	86	23	28	58	54	6	30104214
5,160	+0,004	5	86	23	28	58	54	6	30104216
5,170	+0,004	5	86	23	28	58	54	6	30104218
5,180	+0,004	5	86	23	28	58	54	6	30104220
5,190	+0,004	5	86	23	28	58	54	6	30104222
5,200	+0,004	5	86	23	28	58	54	6	30104224
5,210	+0,004	5	86	23	28	58	54	6	30104226
5,220	+0,004	5	86	23	28	58	54	6	30104228
5,230	+0,004	5	86	23	28	58	54	6	30104230
5,240	+0,004	5	86	23	28	58	54	6	30104232
5,250	+0,004	5	86	23	28	58	54	6	30104234
5,260	+0,004	5	86	23	28	58	54	6	30104236
5,270	+0,004	5	86	23	28	58	54	6	30104238
5,280	+0,004	5	86	23	28	58	54	6	30104240

Continued on next page.

Machine reamer I B030513, fixed design according to DIN 212-1, Form B ($\varnothing \leq 3.75$ mm) or DIN 212-2, Form B ($\varnothing \geq 3.76$ mm)

Dimensions								z	Order no.
d ₁	Tolerance	d ₂ h9	l ₁	l ₂	l ₃	l ₄	l ₅		
5,290	+0,004	5	86	23	28	58	54	6	30104242
5,300	+0,004	5	86	23	28	58	54	6	30104244
5,310	+0,004	5,6	93	26	36	57	53	6	30104246
5,320	+0,004	5,6	93	26	36	57	53	6	30104248
5,330	+0,004	5,6	93	26	36	57	53	6	30104250
5,340	+0,004	5,6	93	26	36	57	53	6	30104252
5,350	+0,004	5,6	93	26	36	57	53	6	30104254
5,360	+0,004	5,6	93	26	36	57	53	6	30104256
5,370	+0,004	5,6	93	26	36	57	53	6	30104258
5,380	+0,004	5,6	93	26	36	57	53	6	30104260
5,390	+0,004	5,6	93	26	36	57	53	6	30104262
5,400	+0,004	5,6	93	26	36	57	53	6	30104264
5,410	+0,004	5,6	93	26	36	57	53	6	30104266
5,420	+0,004	5,6	93	26	36	57	53	6	30104268
5,430	+0,004	5,6	93	26	36	57	53	6	30104270
5,440	+0,004	5,6	93	26	36	57	53	6	30104272
5,450	+0,004	5,6	93	26	36	57	53	6	30104274
5,460	+0,004	5,6	93	26	36	57	53	6	30104276
5,470	+0,004	5,6	93	26	36	57	53	6	30104278
5,480	+0,004	5,6	93	26	36	57	53	6	30104280
5,490	+0,004	5,6	93	26	36	57	53	6	30104282
5,500	+0,004	5,6	93	26	36	57	53	6	30104284
5,510	+0,005	5,6	93	26	36	57	53	6	30104286
5,520	+0,005	5,6	93	26	36	57	53	6	30104288
5,530	+0,005	5,6	93	26	36	57	53	6	30104290
5,540	+0,005	5,6	93	26	36	57	53	6	30104292
5,550	+0,005	5,6	93	26	36	57	53	6	30104294
5,560	+0,005	5,6	93	26	36	57	53	6	30104296
5,570	+0,005	5,6	93	26	36	57	53	6	30104298
5,580	+0,005	5,6	93	26	36	57	53	6	30104300
5,590	+0,005	5,6	93	26	36	57	53	6	30104302
5,600	+0,005	5,6	93	26	36	57	53	6	30104304
5,610	+0,005	5,6	93	26	36	57	53	6	30104306
5,620	+0,005	5,6	93	26	36	57	53	6	30104308
5,630	+0,005	5,6	93	26	36	57	53	6	30104310
5,640	+0,005	5,6	93	26	36	57	53	6	30104312
5,650	+0,005	5,6	93	26	36	57	53	6	30104314
5,660	+0,005	5,6	93	26	36	57	53	6	30104316
5,670	+0,005	5,6	93	26	36	57	53	6	30104318
5,680	+0,005	5,6	93	26	36	57	53	6	30104320
5,690	+0,005	5,6	93	26	36	57	53	6	30104322
5,700	+0,005	5,6	93	26	36	57	53	6	30104324
5,710	+0,005	5,6	93	26	36	57	53	6	30104326
5,720	+0,005	5,6	93	26	36	57	53	6	30104328
5,730	+0,005	5,6	93	26	36	57	53	6	30104330
5,740	+0,005	5,6	93	26	36	57	53	6	30104332
5,750	+0,005	5,6	93	26	36	57	53	6	30104334
5,760	+0,005	5,6	93	26	36	57	53	6	30104336
5,770	+0,005	5,6	93	26	36	57	53	6	30104338
5,780	+0,005	5,6	93	26	36	57	53	6	30104340
5,790	+0,005	5,6	93	26	36	57	53	6	30104342
5,800	+0,005	5,6	93	26	36	57	53	6	30104344
5,810	+0,005	5,6	93	26	36	57	53	6	30104346
5,820	+0,005	5,6	93	26	36	57	53	6	30104348
5,830	+0,005	5,6	93	26	36	57	53	6	30104350
5,840	+0,005	5,6	93	26	36	57	53	6	30104352
5,850	+0,005	5,6	93	26	36	57	53	6	30104354

Machine reamer I B030513, fixed design according to DIN 212-1, Form B ($\varnothing \leq 3.75$ mm) or DIN 212-2, Form B ($\varnothing \geq 3.76$ mm)

Dimensions								z	Order no.
d ₁	Tolerance	d ₂ h9	l ₁	l ₂	l ₃	l ₄	l ₅		
5,860	+0,005	5,6	93	26	36	57	53	6	30104356
5,870	+0,005	5,6	93	26	36	57	53	6	30104358
5,880	+0,005	5,6	93	26	36	57	53	6	30104360
5,890	+0,005	5,6	93	26	36	57	53	6	30104362
5,900	+0,005	5,6	93	26	36	57	53	6	30104364
5,910	+0,005	5,6	93	26	36	57	53	6	30104366
5,920	+0,005	5,6	93	26	36	57	53	6	30104368
5,930	+0,005	5,6	93	26	36	57	53	6	30104370
5,940	+0,005	5,6	93	26	36	57	53	6	30104372
5,950	+0,005	5,6	93	26	36	57	53	6	30104374
5,960	+0,005	5,6	93	26	36	57	53	6	30104376
5,970	+0,005	5,6	93	26	36	57	53	6	30104378
5,980	+0,005	5,6	93	26	36	57	53	6	30104380
5,990	+0,005	5,6	93	26	36	57	53	6	30104382
6,000	+0,005	5,6	93	26	36	57	53	6	30104384
6,010*	+0,005	5,6	93	26	36	57	53	6	30104386
6,020*	+0,005	5,6	93	26	36	57	53	6	30104388
6,030*	+0,005	5,6	93	26	36	57	53	6	30104390
6,040	+0,005	6,3	101	28	36	65	61	6	30104392
6,050	+0,005	6,3	101	28	36	65	61	6	30104394
6,060	+0,005	6,3	101	28	36	65	61	6	30104396
6,070	+0,005	6,3	101	28	36	65	61	6	30104398
6,080	+0,005	6,3	101	28	36	65	61	6	30104400
6,090	+0,005	6,3	101	28	36	65	61	6	30104402
6,100	+0,005	6,3	101	28	36	65	61	6	30104404
6,110	+0,005	6,3	101	28	36	65	61	6	30104406
6,120	+0,005	6,3	101	28	36	65	61	6	30104408
6,130	+0,005	6,3	101	28	36	65	61	6	30104410
6,140	+0,005	6,3	101	28	36	65	61	6	30104412
6,150	+0,005	6,3	101	28	36	65	61	6	30104414
6,160	+0,005	6,3	101	28	36	65	61	6	30104416
6,170	+0,005	6,3	101	28	36	65	61	6	30104418
6,180	+0,005	6,3	101	28	36	65	61	6	30104420
6,190	+0,005	6,3	101	28	36	65	61	6	30104422
6,200	+0,005	6,3	101	28	36	65	61	6	30104424
6,210	+0,005	6,3	101	28	36	65	61	6	30104426
6,220	+0,005	6,3	101	28	36	65	61	6	30104428
6,230	+0,005	6,3	101	28	36	65	61	6	30104430
6,240	+0,005	6,3	101	28	36	65	61	6	30104432
6,250	+0,005	6,3	101	28	36	65	61	6	30104434
6,260	+0,005	6,3	101	28	36	65	61	6	30104436
6,270	+0,005	6,3	101	28	36	65	61	6	30104438
6,280	+0,005	6,3	101	28	36	65	61	6	30104440
6,290	+0,005	6,3	101	28	36	65	61	6	30104442
6,300	+0,005	6,3	101	28	36	65	61	6	30104444
6,310	+0,005	6,3	101	28	36	65	61	6	30104446
6,320	+0,005	6,3	101	28	36	65	61	6	30104448
6,330	+0,005	6,3	101	28	36	65	61	6	30104450
6,340	+0,005	6,3	101	28	36	65	61	6	30104452
6,350	+0,005	6,3	101	28	36	65	61	6	30104454
6,360	+0,005	6,3	101	28	36	65	61	6	30104456
6,370	+0,005	6,3	101	28	36	65	61	6	30104458
6,380	+0,005	6,3	101	28	36	65	61	6	30104460
6,390	+0,005	6,3	101	28	36	65	61	6	30104462
6,400	+0,005	6,3	101	28	36	65	61	6	30104464
6,410	+0,005	6,3	101	28	36	65	61	6	30104466
6,420	+0,005	6,3	101	28	36	65	61	6	30104468

Continued on next page.

Machine reamer I B030513, fixed design according to DIN 212-1, Form B ($\varnothing \leq 3.75$ mm) or DIN 212-2, Form B ($\varnothing \geq 3.76$ mm)

Dimensions								z	Order no.
d ₁	Tolerance	d ₂ h9	l ₁	l ₂	l ₃	l ₄	l ₅		
6,430	+0,005	6,3	101	28	36	65	61	6	30104470
6,440	+0,005	6,3	101	28	36	65	61	6	30104472
6,450	+0,005	6,3	101	28	36	65	61	6	30104474
6,460	+0,005	6,3	101	28	36	65	61	6	30104476
6,470	+0,005	6,3	101	28	36	65	61	6	30104478
6,480	+0,005	6,3	101	28	36	65	61	6	30104480
6,490	+0,005	6,3	101	28	36	65	61	6	30104482
6,500	+0,005	6,3	101	28	36	65	61	6	30104484
6,510	+0,005	6,3	101	28	36	65	61	6	30104486
6,520	+0,005	6,3	101	28	36	65	61	6	30104488
6,530	+0,005	6,3	101	28	36	65	61	6	30104490
6,540	+0,005	6,3	101	28	36	65	61	6	30104492
6,550	+0,005	6,3	101	28	36	65	61	6	30104494
6,560	+0,005	6,3	101	28	36	65	61	6	30104496
6,570	+0,005	6,3	101	28	36	65	61	6	30104498
6,580	+0,005	6,3	101	28	36	65	61	6	30104500
6,590	+0,005	6,3	101	28	36	65	61	6	30104502
6,600	+0,005	6,3	101	28	36	65	61	6	30104504
6,610	+0,005	6,3	101	28	36	65	61	6	30104506
6,620	+0,005	6,3	101	28	36	65	61	6	30104508
6,630	+0,005	6,3	101	28	36	65	61	6	30104510
6,640	+0,005	6,3	101	28	36	65	61	6	30104512
6,650	+0,005	6,3	101	28	36	65	61	6	30104514
6,660	+0,005	6,3	101	28	36	65	61	6	30104516
6,670	+0,005	6,3	101	28	36	65	61	6	30104518
6,680	+0,005	6,3	101	28	36	65	61	6	30104520
6,690	+0,005	6,3	101	28	36	65	61	6	30104522
6,700	+0,005	6,3	101	28	36	65	61	6	30104524
6,710	+0,005	7,1	109	31	36	73	69	6	30104526
6,720	+0,005	7,1	109	31	36	73	69	6	30104528
6,730	+0,005	7,1	109	31	36	73	69	6	30104530
6,740	+0,005	7,1	109	31	36	73	69	6	30104532
6,750	+0,005	7,1	109	31	36	73	69	6	30104534
6,760	+0,005	7,1	109	31	36	73	69	6	30104536
6,770	+0,005	7,1	109	31	36	73	69	6	30104538
6,780	+0,005	7,1	109	31	36	73	69	6	30104540
6,790	+0,005	7,1	109	31	36	73	69	6	30104542
6,800	+0,005	7,1	109	31	36	73	69	6	30104544
6,810	+0,005	7,1	109	31	36	73	69	6	30104546
6,820	+0,005	7,1	109	31	36	73	69	6	30104548
6,830	+0,005	7,1	109	31	36	73	69	6	30104550
6,840	+0,005	7,1	109	31	36	73	69	6	30104552
6,850	+0,005	7,1	109	31	36	73	69	6	30104554
6,860	+0,005	7,1	109	31	36	73	69	6	30104556
6,870	+0,005	7,1	109	31	36	73	69	6	30104558
6,880	+0,005	7,1	109	31	36	73	69	6	30104560
6,890	+0,005	7,1	109	31	36	73	69	6	30104562
6,900	+0,005	7,1	109	31	36	73	69	6	30104564
6,910	+0,005	7,1	109	31	36	73	69	6	30104566
6,920	+0,005	7,1	109	31	36	73	69	6	30104568
6,930	+0,005	7,1	109	31	36	73	69	6	30104570
6,940	+0,005	7,1	109	31	36	73	69	6	30104572
6,950	+0,005	7,1	109	31	36	73	69	6	30104574
6,960	+0,005	7,1	109	31	36	73	69	6	30104576
6,970	+0,005	7,1	109	31	36	73	69	6	30104578
6,980	+0,005	7,1	109	31	36	73	69	6	30104580
6,990	+0,005	7,1	109	31	36	73	69	6	30104582

Machine reamer I B030513, fixed design according to DIN 212-1, Form B ($\varnothing \leq 3.75$ mm) or DIN 212-2, Form B ($\varnothing \geq 3.76$ mm)

Dimensions								z	Order no.
d ₁	Tolerance	d ₂ h9	l ₁	l ₂	l ₃	l ₄	l ₅		
7,000	+0,005	7,1	109	31	36	73	69	6	30104584
7,010	+0,005	7,1	109	31	36	73	69	6	30104586
7,020	+0,005	7,1	109	31	36	73	69	6	30104588
7,030	+0,005	7,1	109	31	36	73	69	6	30104590
7,040	+0,005	7,1	109	31	36	73	69	6	30104592
7,050	+0,005	7,1	109	31	36	73	69	6	30104594
7,060	+0,005	7,1	109	31	36	73	69	6	30104596
7,070	+0,005	7,1	109	31	36	73	69	6	30104598
7,080	+0,005	7,1	109	31	36	73	69	6	30104600
7,090	+0,005	7,1	109	31	36	73	69	6	30104602
7,100	+0,005	7,1	109	31	36	73	69	6	30104604
7,110	+0,005	7,1	109	31	36	73	69	6	30104606
7,120	+0,005	7,1	109	31	36	73	69	6	30104608
7,130	+0,005	7,1	109	31	36	73	69	6	30104610
7,140	+0,005	7,1	109	31	36	73	69	6	30104612
7,150	+0,005	7,1	109	31	36	73	69	6	30104614
7,160	+0,005	7,1	109	31	36	73	69	6	30104616
7,170	+0,005	7,1	109	31	36	73	69	6	30104618
7,180	+0,005	7,1	109	31	36	73	69	6	30104620
7,190	+0,005	7,1	109	31	36	73	69	6	30104622
7,200	+0,005	7,1	109	31	36	73	69	6	30104624
7,210	+0,005	7,1	109	31	36	73	69	6	30104626
7,220	+0,005	7,1	109	31	36	73	69	6	30104628
7,230	+0,005	7,1	109	31	36	73	69	6	30104630
7,240	+0,005	7,1	109	31	36	73	69	6	30104632
7,250	+0,005	7,1	109	31	36	73	69	6	30104634
7,260	+0,005	7,1	109	31	36	73	69	6	30104636
7,270	+0,005	7,1	109	31	36	73	69	6	30104638
7,280	+0,005	7,1	109	31	36	73	69	6	30104640
7,290	+0,005	7,1	109	31	36	73	69	6	30104642
7,300	+0,005	7,1	109	31	36	73	69	6	30104644
7,310	+0,005	7,1	109	31	36	73	69	6	30104646
7,320	+0,005	7,1	109	31	36	73	69	6	30104648
7,330	+0,005	7,1	109	31	36	73	69	6	30104650
7,340	+0,005	7,1	109	31	36	73	69	6	30104652
7,350	+0,005	7,1	109	31	36	73	69	6	30104654
7,360	+0,005	7,1	109	31	36	73	69	6	30104656
7,370	+0,005	7,1	109	31	36	73	69	6	30104658
7,380	+0,005	7,1	109	31	36	73	69	6	30104660
7,390	+0,005	7,1	109	31	36	73	69	6	30104662
7,400	+0,005	7,1	109	31	36	73	69	6	30104664
7,410	+0,005	7,1	109	31	36	73	69	6	30104666
7,420	+0,005	7,1	109	31	36	73	69	6	30104668
7,430	+0,005	7,1	109	31	36	73	69	6	30104670
7,440	+0,005	7,1	109	31	36	73	69	6	30104672
7,450	+0,005	7,1	109	31	36	73	69	6	30104674
7,460	+0,005	7,1	109	31	36	73	69	6	30104676
7,470	+0,005	7,1	109	31	36	73	69	6	30104678
7,480	+0,005	7,1	109	31	36	73	69	6	30104680
7,490	+0,005	7,1	109	31	36	73	69	6	30104682
7,500	+0,005	7,1	109	31	36	73	69	6	30104684
7,510	+0,005	8	117	33	36	81	77	6	30104686
7,520	+0,005	8	117	33	36	81	77	6	30104688
7,530	+0,005	8	117	33	36	81	77	6	30104690
7,540	+0,005	8	117	33	36	81	77	6	30104692
7,550	+0,005	8	117	33	36	81	77	6	30104694
7,560	+0,005	8	117	33	36	81	77	6	30104696

Continued on next page.

Machine reamer I B030513, fixed design according to DIN 212-1, Form B ($\varnothing \leq 3.75$ mm) or DIN 212-2, Form B ($\varnothing \geq 3.76$ mm)

Dimensions								z	Order no.
d ₁	Tolerance	d ₂ h9	l ₁	l ₂	l ₃	l ₄	l ₅		
7,570	+0,005	8	117	33	36	81	77	6	30104698
7,580	+0,005	8	117	33	36	81	77	6	30104700
7,590	+0,005	8	117	33	36	81	77	6	30104702
7,600	+0,005	8	117	33	36	81	77	6	30104704
7,610	+0,005	8	117	33	36	81	77	6	30104706
7,620	+0,005	8	117	33	36	81	77	6	30104708
7,630	+0,005	8	117	33	36	81	77	6	30104710
7,640	+0,005	8	117	33	36	81	77	6	30104712
7,650	+0,005	8	117	33	36	81	77	6	30104714
7,660	+0,005	8	117	33	36	81	77	6	30104716
7,670	+0,005	8	117	33	36	81	77	6	30104718
7,680	+0,005	8	117	33	36	81	77	6	30104720
7,690	+0,005	8	117	33	36	81	77	6	30104722
7,700	+0,005	8	117	33	36	81	77	6	30104724
7,710	+0,005	8	117	33	36	81	77	6	30104726
7,720	+0,005	8	117	33	36	81	77	6	30104728
7,730	+0,005	8	117	33	36	81	77	6	30104730
7,740	+0,005	8	117	33	36	81	77	6	30104732
7,750	+0,005	8	117	33	36	81	77	6	30104734
7,760	+0,005	8	117	33	36	81	77	6	30104736
7,770	+0,005	8	117	33	36	81	77	6	30104738
7,780	+0,005	8	117	33	36	81	77	6	30104740
7,790	+0,005	8	117	33	36	81	77	6	30104742
7,800	+0,005	8	117	33	36	81	77	6	30104744
7,810	+0,005	8	117	33	36	81	77	6	30104746
7,820	+0,005	8	117	33	36	81	77	6	30104748
7,830	+0,005	8	117	33	36	81	77	6	30104750
7,840	+0,005	8	117	33	36	81	77	6	30104752
7,850	+0,005	8	117	33	36	81	77	6	30104754
7,860	+0,005	8	117	33	36	81	77	6	30104756
7,870	+0,005	8	117	33	36	81	77	6	30104758
7,880	+0,005	8	117	33	36	81	77	6	30104760
7,890	+0,005	8	117	33	36	81	77	6	30104762
7,900	+0,005	8	117	33	36	81	77	6	30104764
7,910	+0,005	8	117	33	36	81	77	6	30104766
7,920	+0,005	8	117	33	36	81	77	6	30104768
7,930	+0,005	8	117	33	36	81	77	6	30104770
7,940	+0,005	8	117	33	36	81	77	6	30104772
7,950	+0,005	8	117	33	36	81	77	6	30104774
7,960	+0,005	8	117	33	36	81	77	6	30104776
7,970	+0,005	8	117	33	36	81	77	6	30104778
7,980	+0,005	8	117	33	36	81	77	6	30104780
7,990	+0,005	8	117	33	36	81	77	6	30104782
8,000	+0,005	8	117	33	36	81	77	6	30104784
8,010	+0,005	8	117	33	36	81	77	6	30104786
8,020	+0,005	8	117	33	36	81	77	6	30104788
8,030	+0,005	8	117	33	36	81	77	6	30104790
8,040	+0,005	8	117	33	36	81	77	6	30104792
8,050	+0,005	8	117	33	36	81	77	6	30104794
8,060	+0,005	8	117	33	36	81	77	6	30104796
8,070	+0,005	8	117	33	36	81	77	6	30104798
8,080	+0,005	8	117	33	36	81	77	6	30104800
8,090	+0,005	8	117	33	36	81	77	6	30104802
8,100	+0,005	8	117	33	36	81	77	6	30104804
8,110	+0,005	8	117	33	36	81	77	6	30104806
8,120	+0,005	8	117	33	36	81	77	6	30104808
8,130	+0,005	8	117	33	36	81	77	6	30104810

Machine reamer I B030513, fixed design according to DIN 212-1, Form B ($\varnothing \leq 3.75$ mm) or DIN 212-2, Form B ($\varnothing \geq 3.76$ mm)

Dimensions								z	Order no.
d ₁	Tolerance	d ₂ h9	l ₁	l ₂	l ₃	l ₄	l ₅		
8,140	+0,005	8	117	33	36	81	77	6	30104812
8,150	+0,005	8	117	33	36	81	77	6	30104814
8,160	+0,005	8	117	33	36	81	77	6	30104816
8,170	+0,005	8	117	33	36	81	77	6	30104818
8,180	+0,005	8	117	33	36	81	77	6	30104820
8,190	+0,005	8	117	33	36	81	77	6	30104822
8,200	+0,005	8	117	33	36	81	77	6	30104824
8,210	+0,005	8	117	33	36	81	77	6	30104826
8,220	+0,005	8	117	33	36	81	77	6	30104828
8,230	+0,005	8	117	33	36	81	77	6	30104830
8,240	+0,005	8	117	33	36	81	77	6	30104832
8,250	+0,005	8	117	33	36	81	77	6	30104834
8,260	+0,005	8	117	33	36	81	77	6	30104836
8,270	+0,005	8	117	33	36	81	77	6	30104838
8,280	+0,005	8	117	33	36	81	77	6	30104840
8,290	+0,005	8	117	33	36	81	77	6	30104842
8,300	+0,005	8	117	33	36	81	77	6	30104844
8,310	+0,005	8	117	33	36	81	77	6	30104846
8,320	+0,005	8	117	33	36	81	77	6	30104848
8,330	+0,005	8	117	33	36	81	77	6	30104850
8,340	+0,005	8	117	33	36	81	77	6	30104852
8,350	+0,005	8	117	33	36	81	77	6	30104854
8,360	+0,005	8	117	33	36	81	77	6	30104856
8,370	+0,005	8	117	33	36	81	77	6	30104858
8,380	+0,005	8	117	33	36	81	77	6	30104860
8,390	+0,005	8	117	33	36	81	77	6	30104862
8,400	+0,005	8	117	33	36	81	77	6	30104864
8,410	+0,005	8	117	33	36	81	77	6	30104866
8,420	+0,005	8	117	33	36	81	77	6	30104868
8,430	+0,005	8	117	33	36	81	77	6	30104870
8,440	+0,005	8	117	33	36	81	77	6	30104872
8,450	+0,005	8	117	33	36	81	77	6	30104874
8,460	+0,005	8	117	33	36	81	77	6	30104876
8,470	+0,005	8	117	33	36	81	77	6	30104878
8,480	+0,005	8	117	33	36	81	77	6	30104880
8,490	+0,005	8	117	33	36	81	77	6	30104882
8,500	+0,005	8	117	33	36	81	77	6	30104884
8,510	+0,005	9	125	36	40	85	81	6	30104886
8,520	+0,005	9	125	36	40	85	81	6	30104888
8,530	+0,005	9	125	36	40	85	81	6	30104890
8,540	+0,005	9	125	36	40	85	81	6	30104892
8,550	+0,005	9	125	36	40	85	81	6	30104894
8,560	+0,005	9	125	36	40	85	81	6	30104896
8,570	+0,005	9	125	36	40	85	81	6	30104898
8,580	+0,005	9	125	36	40	85	81	6	30104900
8,590	+0,005	9	125	36	40	85	81	6	30104902
8,600	+0,005	9	125	36	40	85	81	6	30104904
8,610	+0,005	9	125	36	40	85	81	6	30104906
8,620	+0,005	9	125	36	40	85	81	6	30104908
8,630	+0,005	9	125	36	40	85	81	6	30104910
8,640	+0,005	9	125	36	40	85	81	6	30104912
8,650	+0,005	9	125	36	40	85	81	6	30104914
8,660	+0,005	9	125	36	40	85	81	6	30104916
8,670	+0,005	9	125	36	40	85	81	6	30104918
8,680	+0,005	9	125	36	40	85	81	6	30104920
8,690	+0,005	9	125	36	40	85	81	6	30104922
8,700	+0,005	9	125	36	40	85	81	6	30104924

Continued on next page.

Machine reamer I B030513, fixed design according to DIN 212-1, Form B ($\varnothing \leq 3.75$ mm) or DIN 212-2, Form B ($\varnothing \geq 3.76$ mm)

Dimensions								z	Order no.
d ₁	Tolerance	d ₂ h9	l ₁	l ₂	l ₃	l ₄	l ₅		
8,710	+0,005	9	125	36	40	85	81	6	30104926
8,720	+0,005	9	125	36	40	85	81	6	30104928
8,730	+0,005	9	125	36	40	85	81	6	30104930
8,740	+0,005	9	125	36	40	85	81	6	30104932
8,750	+0,005	9	125	36	40	85	81	6	30104934
8,760	+0,005	9	125	36	40	85	81	6	30104936
8,770	+0,005	9	125	36	40	85	81	6	30104938
8,780	+0,005	9	125	36	40	85	81	6	30104940
8,790	+0,005	9	125	36	40	85	81	6	30104942
8,800	+0,005	9	125	36	40	85	81	6	30104944
8,810	+0,005	9	125	36	40	85	81	6	30104946
8,820	+0,005	9	125	36	40	85	81	6	30104948
8,830	+0,005	9	125	36	40	85	81	6	30104950
8,840	+0,005	9	125	36	40	85	81	6	30104952
8,850	+0,005	9	125	36	40	85	81	6	30104954
8,860	+0,005	9	125	36	40	85	81	6	30104956
8,870	+0,005	9	125	36	40	85	81	6	30104958
8,880	+0,005	9	125	36	40	85	81	6	30104960
8,890	+0,005	9	125	36	40	85	81	6	30104962
8,900	+0,005	9	125	36	40	85	81	6	30104964
8,910	+0,005	9	125	36	40	85	81	6	30104966
8,920	+0,005	9	125	36	40	85	81	6	30104968
8,930	+0,005	9	125	36	40	85	81	6	30104970
8,940	+0,005	9	125	36	40	85	81	6	30104972
8,950	+0,005	9	125	36	40	85	81	6	30104974
8,960	+0,005	9	125	36	40	85	81	6	30104976
8,970	+0,005	9	125	36	40	85	81	6	30104978
8,980	+0,005	9	125	36	40	85	81	6	30104980
8,990	+0,005	9	125	36	40	85	81	6	30104982
9,000	+0,005	9	125	36	40	85	81	6	30104984
9,010	+0,005	9	125	36	40	85	81	6	30104986
9,020	+0,005	9	125	36	40	85	81	6	30104988
9,030	+0,005	9	125	36	40	85	81	6	30104990
9,040	+0,005	9	125	36	40	85	81	6	30104992
9,050	+0,005	9	125	36	40	85	81	6	30104994
9,060	+0,005	9	125	36	40	85	81	6	30104996
9,070	+0,005	9	125	36	40	85	81	6	30104998
9,080	+0,005	9	125	36	40	85	81	6	30105000
9,090	+0,005	9	125	36	40	85	81	6	30105002
9,100	+0,005	9	125	36	40	85	81	6	30105004
9,110	+0,005	9	125	36	40	85	81	6	30105006
9,120	+0,005	9	125	36	40	85	81	6	30105008
9,130	+0,005	9	125	36	40	85	81	6	30105010
9,140	+0,005	9	125	36	40	85	81	6	30105012
9,150	+0,005	9	125	36	40	85	81	6	30105014
9,160	+0,005	9	125	36	40	85	81	6	30105016
9,170	+0,005	9	125	36	40	85	81	6	30105018
9,180	+0,005	9	125	36	40	85	81	6	30105020
9,190	+0,005	9	125	36	40	85	81	6	30105022
9,200	+0,005	9	125	36	40	85	81	6	30105024
9,210	+0,005	9	125	36	40	85	81	6	30105026
9,220	+0,005	9	125	36	40	85	81	6	30105028
9,230	+0,005	9	125	36	40	85	81	6	30105030
9,240	+0,005	9	125	36	40	85	81	6	30105032
9,250	+0,005	9	125	36	40	85	81	6	30105034
9,260	+0,005	9	125	36	40	85	81	6	30105036
9,270	+0,005	9	125	36	40	85	81	6	30105038

Machine reamer I B030513, fixed design according to DIN 212-1, Form B ($\varnothing \leq 3.75$ mm) or DIN 212-2, Form B ($\varnothing \geq 3.76$ mm)

Dimensions								z	Order no.
d ₁	Tolerance	d ₂ h9	l ₁	l ₂	l ₃	l ₄	l ₅		
9,280	+0,005	9	125	36	40	85	81	6	30105040
9,290	+0,005	9	125	36	40	85	81	6	30105042
9,300	+0,005	9	125	36	40	85	81	6	30105044
9,310	+0,005	9	125	36	40	85	81	6	30105046
9,320	+0,005	9	125	36	40	85	81	6	30105048
9,330	+0,005	9	125	36	40	85	81	6	30105050
9,340	+0,005	9	125	36	40	85	81	6	30105052
9,350	+0,005	9	125	36	40	85	81	6	30105054
9,360	+0,005	9	125	36	40	85	81	6	30105056
9,370	+0,005	9	125	36	40	85	81	6	30105058
9,380	+0,005	9	125	36	40	85	81	6	30105060
9,390	+0,005	9	125	36	40	85	81	6	30105062
9,400	+0,005	9	125	36	40	85	81	6	30105064
9,410	+0,005	9	125	36	40	85	81	6	30105066
9,420	+0,005	9	125	36	40	85	81	6	30105068
9,430	+0,005	9	125	36	40	85	81	6	30105070
9,440	+0,005	9	125	36	40	85	81	6	30105072
9,450	+0,005	9	125	36	40	85	81	6	30105074
9,460	+0,005	9	125	36	40	85	81	6	30105076
9,470	+0,005	9	125	36	40	85	81	6	30105078
9,480	+0,005	9	125	36	40	85	81	6	30105090
9,490	+0,005	9	125	36	40	85	81	6	30105092
9,500	+0,005	9	125	36	40	85	81	6	30105094
9,510	+0,005	10	133	38	40	93	89	6	30105096
9,520	+0,005	10	133	38	40	93	89	6	30105098
9,530	+0,005	10	133	38	40	93	89	6	30105100
9,540	+0,005	10	133	38	40	93	89	6	30105102
9,550	+0,005	10	133	38	40	93	89	6	30105104
9,560	+0,005	10	133	38	40	93	89	6	30105106
9,570	+0,005	10	133	38	40	93	89	6	30105108
9,580	+0,005	10	133	38	40	93	89	6	30105110
9,590	+0,005	10	133	38	40	93	89	6	30105112
9,600	+0,005	10	133	38	40	93	89	6	30105114
9,610	+0,005	10	133	38	40	93	89	6	30105116
9,620	+0,005	10	133	38	40	93	89	6	30105118
9,630	+0,005	10	133	38	40	93	89	6	30105120
9,640	+0,005	10	133	38	40	93	89	6	30105122
9,650	+0,005	10	133	38	40	93	89	6	30105124
9,660	+0,005	10	133	38	40	93	89	6	30105126
9,670	+0,005	10	133	38	40	93	89	6	30105128
9,680	+0,005	10	133	38	40	93	89	6	30105130
9,690	+0,005	10	133	38	40	93	89	6	30105132
9,700	+0,005	10	133	38	40	93	89	6	30105134
9,710	+0,005	10	133	38	40	93	89	6	30105136
9,720	+0,005	10	133	38	40	93	89	6	30105138
9,730	+0,005	10	133	38	40	93	89	6	30105140
9,740	+0,005	10	133	38	40	93	89	6	30105142
9,750	+0,005	10	133	38	40	93	89	6	30105144
9,760	+0,005	10	133	38	40	93	89	6	30105146
9,770	+0,005	10	133	38	40	93	89	6	30105148
9,780	+0,005	10	133	38	40	93	89	6	30105150
9,790	+0,005	10	133	38	40	93	89	6	30105152
9,800	+0,005	10	133	38	40	93	89	6	30105154
9,810	+0,005	10	133	38	40	93	89	6	30105156
9,820	+0,005	10	133	38	40	93	89	6	30105158
9,830	+0,005	10	133	38	40	93	89	6	30105160
9,840	+0,005	10	133	38	40	93	89	6	30105162

Continued on next page.

Machine reamer I B030513, fixed design according to DIN 212-1, Form B ($\varnothing \leq 3.75$ mm) or DIN 212-2, Form B ($\varnothing \geq 3.76$ mm)

Dimensions								z	Order no.
d ₁	Tolerance	d ₂ h9	l ₁	l ₂	l ₃	l ₄	l ₅		
9,850	+0,005	10	133	38	40	93	89	6	30105164
9,860	+0,005	10	133	38	40	93	89	6	30105166
9,870	+0,005	10	133	38	40	93	89	6	30105168
9,880	+0,005	10	133	38	40	93	89	6	30105170
9,890	+0,005	10	133	38	40	93	89	6	30105172
9,900	+0,005	10	133	38	40	93	89	6	30105174
9,910	+0,005	10	133	38	40	93	89	6	30105176
9,920	+0,005	10	133	38	40	93	89	6	30105178
9,930	+0,005	10	133	38	40	93	89	6	30105180
9,940	+0,005	10	133	38	40	93	89	6	30105182
9,950	+0,005	10	133	38	40	93	89	6	30105184
9,960	+0,005	10	133	38	40	93	89	6	30105186
9,970	+0,005	10	133	38	40	93	89	6	30105188
9,980	+0,005	10	133	38	40	93	89	6	30105190
9,990	+0,005	10	133	38	40	93	89	6	30105192
10,000	+0,005	10	133	38	40	93	89	6	30105194
10,010	+0,005	10	133	38	40	93	89	6	30105196
10,020	+0,005	10	133	38	40	93	89	6	30105198
10,030	+0,005	10	133	38	40	93	89	6	30105200
10,040	+0,005	10	133	38	40	93	89	6	30105202
10,050	+0,005	10	133	38	40	93	89	6	30105204
10,060	+0,005	10	133	38	40	93	89	6	30105206
10,070	+0,005	10	133	38	40	93	89	6	30105208
10,080	+0,005	10	133	38	40	93	89	6	30105210
10,090	+0,005	10	133	38	40	93	89	6	30105212
10,100	+0,005	10	133	38	40	93	89	6	30105214
10,110	+0,005	10	133	38	40	93	89	6	30105216
10,120	+0,005	10	133	38	40	93	89	6	30105218
10,130	+0,005	10	133	38	40	93	89	6	30105220
10,140	+0,005	10	133	38	40	93	89	6	30105222
10,150	+0,005	10	133	38	40	93	89	6	30105224
10,160	+0,005	10	133	38	40	93	89	6	30105226
10,170	+0,005	10	133	38	40	93	89	6	30105228
10,180	+0,005	10	133	38	40	93	89	6	30105230
10,190	+0,005	10	133	38	40	93	89	6	30105232
10,200	+0,005	10	133	38	40	93	89	6	30105234
10,210	+0,005	10	133	38	40	93	89	6	30105236
10,220	+0,005	10	133	38	40	93	89	6	30105238
10,230	+0,005	10	133	38	40	93	89	6	30105240
10,240	+0,005	10	133	38	40	93	89	6	30105242
10,250	+0,005	10	133	38	40	93	89	6	30105244
10,260	+0,005	10	133	38	40	93	89	6	30105246
10,270	+0,005	10	133	38	40	93	89	6	30105248
10,280	+0,005	10	133	38	40	93	89	6	30105250
10,290	+0,005	10	133	38	40	93	89	6	30105252
10,300	+0,005	10	133	38	40	93	89	6	30105254
10,310	+0,005	10	133	38	40	93	89	6	30105256
10,320	+0,005	10	133	38	40	93	89	6	30105258
10,330	+0,005	10	133	38	40	93	89	6	30105260
10,340	+0,005	10	133	38	40	93	89	6	30105262
10,350	+0,005	10	133	38	40	93	89	6	30105264
10,360	+0,005	10	133	38	40	93	89	6	30105266
10,370	+0,005	10	133	38	40	93	89	6	30105268
10,380	+0,005	10	133	38	40	93	89	6	30105270
10,390	+0,005	10	133	38	40	93	89	6	30105272
10,400	+0,005	10	133	38	40	93	89	6	30105274
10,410	+0,005	10	133	38	40	93	89	6	30105276

Machine reamer I B030513, fixed design according to DIN 212-1, Form B ($\varnothing \leq 3.75$ mm) or DIN 212-2, Form B ($\varnothing \geq 3.76$ mm)

Dimensions								z	Order no.
d ₁	Tolerance	d ₂ h9	l ₁	l ₂	l ₃	l ₄	l ₅		
10,420	+0,005	10	133	38	40	93	89	6	30105278
10,430	+0,005	10	133	38	40	93	89	6	30105280
10,440	+0,005	10	133	38	40	93	89	6	30105282
10,450	+0,005	10	133	38	40	93	89	6	30105284
10,460	+0,005	10	133	38	40	93	89	6	30105286
10,470	+0,005	10	133	38	40	93	89	6	30105288
10,480	+0,005	10	133	38	40	93	89	6	30105290
10,490	+0,005	10	133	38	40	93	89	6	30105292
10,500	+0,005	10	133	38	40	93	89	6	30105294
10,510	+0,005	10	133	38	40	93	89	6	30105296
10,520	+0,005	10	133	38	40	93	89	6	30105298
10,530	+0,005	10	133	38	40	93	89	6	30105300
10,540	+0,005	10	133	38	40	93	89	6	30105302
10,550	+0,005	10	133	38	40	93	89	6	30105304
10,560	+0,005	10	133	38	40	93	89	6	30105306
10,570	+0,005	10	133	38	40	93	89	6	30105308
10,580	+0,005	10	133	38	40	93	89	6	30105310
10,590	+0,005	10	133	38	40	93	89	6	30105312
10,600	+0,005	10	133	38	40	93	89	6	30105314
10,610	+0,005	10	142	41	40	102	98	6	30105316
10,620	+0,005	10	142	41	40	102	98	6	30105318
10,630	+0,005	10	142	41	40	102	98	6	30105320
10,640	+0,005	10	142	41	40	102	98	6	30105322
10,650	+0,005	10	142	41	40	102	98	6	30105324
10,660	+0,005	10	142	41	40	102	98	6	30105326
10,670	+0,005	10	142	41	40	102	98	6	30105328
10,680	+0,005	10	142	41	40	102	98	6	30105330
10,690	+0,005	10	142	41	40	102	98	6	30105332
10,700	+0,005	10	142	41	40	102	98	6	30105334
10,710	+0,005	10	142	41	40	102	98	6	30105336
10,720	+0,005	10	142	41	40	102	98	6	30105338
10,730	+0,005	10	142	41	40	102	98	6	30105340
10,740	+0,005	10	142	41	40	102	98	6	30105342
10,750	+0,005	10	142	41	40	102	98	6	30105344
10,760	+0,005	10	142	41	40	102	98	6	30105346
10,770	+0,005	10	142	41	40	102	98	6	30105348
10,780	+0,005	10	142	41	40	102	98	6	30105350
10,790	+0,005	10	142	41	40	102	98	6	30105352
10,800	+0,005	10	142	41	40	102	98	6	30105354
10,810	+0,005	10	142	41	40	102	98	6	30105356
10,820	+0,005	10	142	41	40	102	98	6	30105358
10,830	+0,005	10	142	41	40	102	98	6	30105360
10,840	+0,005	10	142	41	40	102	98	6	30105362
10,850	+0,005	10	142	41	40	102	98	6	30105364
10,860	+0,005	10	142	41	40	102	98	6	30105366
10,870	+0,005	10	142	41	40	102	98	6	30105368
10,880	+0,005	10	142	41	40	102	98	6	30105370
10,890	+0,005	10	142	41	40	102	98	6	30105372
10,900	+0,005	10	142	41	40	102	98	6	30105374
10,910	+0,005	10	142	41	40	102	98	6	30105376
10,920	+0,005	10	142	41	40	102	98	6	30105378
10,930	+0,005	10	142	41	40	102	98	6	30105380
10,940	+0,005	10	142	41	40	102	98	6	30105382
10,950	+0,005	10	142	41	40	102	98	6	30105384
10,960	+0,005	10	142	41	40	102	98	6	30105386
10,970	+0,005	10	142	41	40	102	98	6	30105388
10,980	+0,005	10	142	41	40	102	98	6	30105390

Continued on next page.

Machine reamer I B030513, fixed design according to DIN 212-1, Form B ($\varnothing \leq 3.75$ mm) or DIN 212-2, Form B ($\varnothing \geq 3.76$ mm)

Dimensions								z	Order no.
d ₁	Tolerance	d ₂ h9	l ₁	l ₂	l ₃	l ₄	l ₅		
10,990	+0,005	10	142	41	40	102	98	6	30105392
11,000	+0,005	10	142	41	40	102	98	6	30105394
11,010	+0,005	10	142	41	40	102	98	6	30105396
11,020	+0,005	10	142	41	40	102	98	6	30105398
11,030	+0,005	10	142	41	40	102	98	6	30105400
11,040	+0,005	10	142	41	40	102	98	6	30105402
11,050	+0,005	10	142	41	40	102	98	6	30105404
11,060	+0,005	10	142	41	40	102	98	6	30105406
11,070	+0,005	10	142	41	40	102	98	6	30105408
11,080	+0,005	10	142	41	40	102	98	6	30105410
11,090	+0,005	10	142	41	40	102	98	6	30105412
11,100	+0,005	10	142	41	40	102	98	6	30105414
11,110	+0,005	10	142	41	40	102	98	6	30105416
11,120	+0,005	10	142	41	40	102	98	6	30105418
11,130	+0,005	10	142	41	40	102	98	6	30105420
11,140	+0,005	10	142	41	40	102	98	6	30105422
11,150	+0,005	10	142	41	40	102	98	6	30105424
11,160	+0,005	10	142	41	40	102	98	6	30105426
11,170	+0,005	10	142	41	40	102	98	6	30105428
11,180	+0,005	10	142	41	40	102	98	6	30105430
11,190	+0,005	10	142	41	40	102	98	6	30105432
11,200	+0,005	10	142	41	40	102	98	6	30105434
11,210	+0,005	10	142	41	40	102	98	6	30105436
11,220	+0,005	10	142	41	40	102	98	6	30105438
11,230	+0,005	10	142	41	40	102	98	6	30105440
11,240	+0,005	10	142	41	40	102	98	6	30105442
11,250	+0,005	10	142	41	40	102	98	6	30105444
11,260	+0,005	10	142	41	40	102	98	6	30105446
11,270	+0,005	10	142	41	40	102	98	6	30105448
11,280	+0,005	10	142	41	40	102	98	6	30105450
11,290	+0,005	10	142	41	40	102	98	6	30105452
11,300	+0,005	10	142	41	40	102	98	6	30105454
11,310	+0,005	10	142	41	40	102	98	6	30105456
11,320	+0,005	10	142	41	40	102	98	6	30105458
11,330	+0,005	10	142	41	40	102	98	6	30105460
11,340	+0,005	10	142	41	40	102	98	6	30105462
11,350	+0,005	10	142	41	40	102	98	6	30105464
11,360	+0,005	10	142	41	40	102	98	6	30105466
11,370	+0,005	10	142	41	40	102	98	6	30105468
11,380	+0,005	10	142	41	40	102	98	6	30105470
11,390	+0,005	10	142	41	40	102	98	6	30105472
11,400	+0,005	10	142	41	40	102	98	6	30105474
11,410	+0,005	10	142	41	40	102	98	6	30105476
11,420	+0,005	10	142	41	40	102	98	6	30105478
11,430	+0,005	10	142	41	40	102	98	6	30105480
11,440	+0,005	10	142	41	40	102	98	6	30105482
11,450	+0,005	10	142	41	40	102	98	6	30105484
11,460	+0,005	10	142	41	40	102	98	6	30105486
11,470	+0,005	10	142	41	40	102	98	6	30105488
11,480	+0,005	10	142	41	40	102	98	6	30105490
11,490	+0,005	10	142	41	40	102	98	6	30105492
11,500	+0,005	10	142	41	40	102	98	6	30105494
11,510	+0,005	10	142	41	40	102	98	6	30105496
11,520	+0,005	10	142	41	40	102	98	6	30105498
11,530	+0,005	10	142	41	40	102	98	6	30105500
11,540	+0,005	10	142	41	40	102	98	6	30105502
11,550	+0,005	10	142	41	40	102	98	6	30105504

Machine reamer I B030513, fixed design according to DIN 212-1, Form B ($\varnothing \leq 3.75$ mm) or DIN 212-2, Form B ($\varnothing \geq 3.76$ mm)

Dimensions								z	Order no.
d ₁	Tolerance	d ₂ h9	l ₁	l ₂	l ₃	l ₄	l ₅		
11,560	+0,005	10	142	41	40	102	98	6	30105506
11,570	+0,005	10	142	41	40	102	98	6	30105508
11,580	+0,005	10	142	41	40	102	98	6	30105510
11,590	+0,005	10	142	41	40	102	98	6	30105512
11,600	+0,005	10	142	41	40	102	98	6	30105514
11,610	+0,005	10	142	41	40	102	98	6	30105516
11,620	+0,005	10	142	41	40	102	98	6	30105518
11,630	+0,005	10	142	41	40	102	98	6	30105520
11,640	+0,005	10	142	41	40	102	98	6	30105522
11,650	+0,005	10	142	41	40	102	98	6	30105524
11,660	+0,005	10	142	41	40	102	98	6	30105526
11,670	+0,005	10	142	41	40	102	98	6	30105528
11,680	+0,005	10	142	41	40	102	98	6	30105530
11,690	+0,005	10	142	41	40	102	98	6	30105532
11,700	+0,005	10	142	41	40	102	98	6	30105534
11,710	+0,005	10	142	41	40	102	98	6	30105536
11,720	+0,005	10	142	41	40	102	98	6	30105538
11,730	+0,005	10	142	41	40	102	98	6	30105540
11,740	+0,005	10	142	41	40	102	98	6	30105542
11,750	+0,005	10	142	41	40	102	98	6	30105544
11,760	+0,005	10	142	41	40	102	98	6	30105546
11,770	+0,005	10	142	41	40	102	98	6	30105548
11,780	+0,005	10	142	41	40	102	98	6	30105550
11,790	+0,005	10	142	41	40	102	98	6	30105552
11,800	+0,005	10	142	41	40	102	98	6	30105554
11,810	+0,005	10	151	44	40	111	106	6	30105556
11,820	+0,005	10	151	44	40	111	106	6	30105558
11,830	+0,005	10	151	44	40	111	106	6	30105560
11,840	+0,005	10	151	44	40	111	106	6	30105562
11,850	+0,005	10	151	44	40	111	106	6	30105564
11,860	+0,005	10	151	44	40	111	106	6	30105566
11,870	+0,005	10	151	44	40	111	106	6	30105568
11,880	+0,005	10	151	44	40	111	106	6	30105570
11,890	+0,005	10	151	44	40	111	106	6	30105572
11,900	+0,005	10	151	44	40	111	106	6	30105574
11,910	+0,005	10	151	44	40	111	106	6	30105576
11,920	+0,005	10	151	44	40	111	106	6	30105578
11,930	+0,005	10	151	44	40	111	106	6	30105580
11,940	+0,005	10	151	44	40	111	106	6	30105582
11,950	+0,005	10	151	44	40	111	106	6	30105584
11,960	+0,005	10	151	44	40	111	106	6	30105586
11,970	+0,005	10	151	44	40	111	106	6	30105588
11,980	+0,005	10	151	44	40	111	106	6	30105590
11,990	+0,005	10	151	44	40	111	106	6	30105592
12,000	+0,005	10	151	44	40	111	106	6	30105594
12,010	+0,005	10	151	44	40	111	106	6	30105596
12,020	+0,005	10	151	44	40	111	106	6	30105598
12,030	+0,005	10	151	44	40	111	106	6	30105600
12,040	+0,005	10	151	44	40	111	106	6	30105602
12,050	+0,005	10	151	44	40	111	106	6	30105604

Dimensions in mm.

For cutting data recommendations, see end of chapter.

Special designs and possible coatings available upon request.

* Minimal deviation from the standard for manufacturing reasons.

Machine reamer | B030110

Fixed design with morse taper shank

Design:

Diameter:

4.751 - 33.500 mm

Cutting direction:

Right-hand cutting

Cutting material:

HSS-E, uncoated (SU344)

Groove direction:

Straight fluted

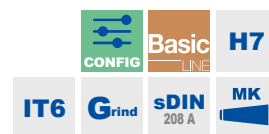
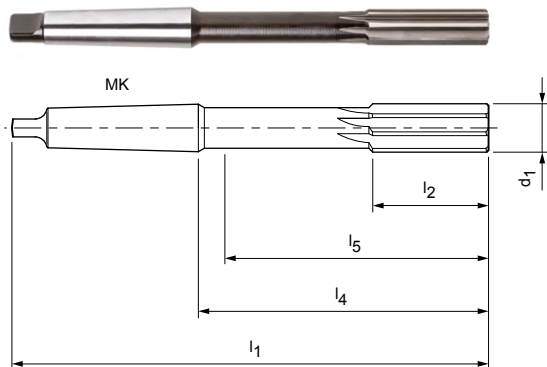

Preferred series in H7

Dimensions						z	Order no.
d ₁ H7	MK	l ₁	l ₂	l ₄	l ₅		
5,000	1	133	23	67,5	58	6	30102665
6,000	1	138	26	72,5	64	6	30102667
7,000	1	150	31	84,5	76	6	30102669
8,000	1	156	33	90,5	83	6	30102671
9,000	1	162	36	96,5	90	6	30102673
10,000	1	168	38	102,5	96	6	30102675
11,000	1	175	41	109,5	105	6	30102677
12,000	1	182	44	116,5	112	6	30102679
13,000	1	182	44	116,5	112	6	30102681
14,000	1	189	47	123,5	119	8	30102683
15,000	2	204	50	124	117	8	30102685
16,000	2	210	52	130	124	8	30102687
17,000	2	214	54	134	129	8	30102689
18,000	2	219	56	139	134	8	30102691
19,000	2	223	58	143	138	8	30102693
20,000	2	228	60	148	143	8	30102695
21,000	2	232	62	152	147	8	30102697
22,000	2	237	64	157	152	8	30102699
23,000	2	241	66	161	156	8	30102701
24,000	3	268	68	169	164	8	30102703
25,000	3	268	68	169	164	8	30102705
26,000	3	273	70	174	169	8	30102707
27,000	3	277	71	178	173	10	30102709
28,000	3	277	71	178	173	10	30102711
29,000	3	281	73	182	177	10	30102713
30,000	3	281	73	182	177	10	30102715
31,000	3	285	75	186	181	10	30102717
32,000	4	317	77	193	188	10	30102719

Configurable features



Bore diameter tolerance \geq IT6:
 - Diameter in increments of 0.001 mm freely selectable
 - Can be ordered in tolerance \geq IT6



Specification:
 B030110[Diameter][Tolerance]

G variant (see page 303):
 - Diameter in increments of 0.001 mm freely selectable
 - Can be ordered from tolerances $\geq 4 \mu\text{m}$

G variant specification:
 B030110[Diameter][Tolerance]

IT6 tolerance example:
 B030110-Ø16.350H6

Bore diameter $d_1 = 16.350 \text{ H6}$

G variant example:
 B030110-Ø16.350-4

Special tool diameter $d_1 = 16.350 -4 \mu\text{m}$

Dimensions of configurable series IT6

d_1	MK	l_1	l_2	l_4	l_5	z
4,751-5,300	1	133	23	67,5	58	6
5,301-6,050	1	138	26	72,5	64	6
6,051-6,700	1	144	28	78,5	70	6
6,701-7,500	1	150	31	84,5	76	6
7,501-8,500	1	156	33	90,5	83	6
8,501-9,500	1	162	36	96,5	90	6
9,501-10,600	1	168	38	102,5	96	6
10,601-11,800	1	175	41	109,5	105	6
11,801-13,200	1	182	44	116,5	112	6
13,201-14,100	1	189	47	123,5	119	8
14,101-15,100	2	204	50	124	117	8
15,101-16,100	2	210	52	130	124	8
16,101-17,100	2	214	54	134	129	8
17,101-18,100	2	219	56	139	134	8
18,101-19,100	2	223	58	143	138	8
19,101-20,100	2	228	60	148	143	8
20,101-21,200	2	232	62	152	147	8
21,201-22,400	2	237	64	157	152	8
22,401-23,600	2	241	66	161	156	8
23,601-25,100	3	268	68	169	164	8
25,101-26,500	3	273	70	174	169	8
26,501-28,100	3	277	71	178	173	10
28,101-30,100	3	281	73	182	177	10
30,101-31,500	3	285	75	186	181	10
31,501-33,500	4	317	77	193	188	10

Dimensions in mm.

For cutting data recommendations, see end of chapter.

Special designs and possible coatings available upon request.

Machine reamer | B030111

Fixed design with morse taper shank

Design:

Diameter:

Cutting direction:

Cutting material:

Groove direction:

2.800 - 50.100 mm

Right-hand cutting

HSS-E, uncoated (SU344)

Spiral fluted

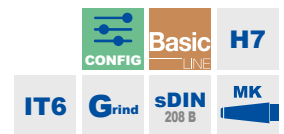
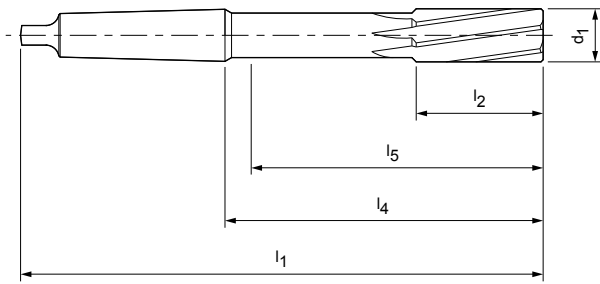
Preferred series in H7

Dimensions						z	Order no.
d ₁ H7	MK	l ₁	l ₂	l ₄	l ₅		
3,000	1	113	15	47,5	42	6	30102748
4,000	1	124	19	58,5	53	6	30102750
5,000	1	133	23	67,5	58	6	30102752
6,000	1	138	26	72,5	64	6	30102754
7,000	1	150	31	84,5	76	6	30102756
8,000	1	156	33	90,5	83	6	30102758
9,000	1	162	36	96,5	90	6	30102760
10,000	1	168	38	102,5	96	6	30102762
11,000	1	175	41	109,5	105	6	30102764
12,000	1	182	44	116,5	112	6	30102766
13,000	1	182	44	116,5	112	6	30102768
14,000	1	189	47	123,5	119	8	30102770
15,000	2	204	50	124	117	8	30102772
16,000	2	210	52	130	124	8	30102774
17,000	2	214	54	134	129	8	30102776
18,000	2	219	56	139	134	8	30102778
19,000	2	223	58	143	138	8	30102780
20,000	2	228	60	148	143	8	30102782
21,000	2	232	62	152	147	8	30102784
22,000	2	237	64	157	152	8	30102786
23,000	2	241	66	161	156	8	30102788
24,000	3	268	68	169	164	8	30102790
25,000	3	268	68	169	164	8	30102792
26,000	3	273	70	174	169	8	30102794
27,000	3	277	71	178	173	10	30102796
28,000	3	277	71	178	173	10	30102798
29,000	3	281	73	182	177	10	30102800
30,000	3	281	73	182	177	10	30102802
31,000	3	285	75	186	181	10	30102804
32,000	4	317	77	193	188	10	30102806
33,000	4	317	77	193	188	10	30102808
34,000	4	321	78	197	191	10	30102810
35,000	4	321	78	197	191	10	30102812
36,000	4	325	79	201	195	10	30102814
37,000	4	325	79	201	195	10	30102816

Machine reamer I B030111, fixed design according to DIN 208, Form B

Dimensions						z	Order no.
d ₁ H7	MK	l ₁	l ₂	l ₄	l ₅		
38,000	4	329	81	205	199	10	30102818
40,000	4	329	81	205	199	10	30102820
42,000	4	333	82	209	204	12	30102822
44,000	4	336	83	212	206	12	30102824
45,000	4	336	83	212	206	12	30102826
46,000	4	340	84	216	210	12	30102828
47,000	4	340	84	216	210	12	30102830
48,000	4	344	86	220	214	12	30102832
50,000	4	344	86	220	214	12	30102834

Configurable features



Bore diameter tolerance ≥ IT6:
 - Diameter in increments of 0.001 mm freely selectable
 - Can be ordered in tolerance ≥ IT6



Specification:
 B030111[Diameter][Tolerance]

G variant (see page 303):
 - Diameter in increments of 0.001 mm freely selectable
 - Can be ordered from tolerances ≥ 4 μm

G variant specification:
 B030111[Diameter][Tolerance]

IT6 tolerance example:
 B030111-Ø16.350H6

Bore diameter d₁ = 16.350 H6

G variant example:
 B030111-Ø16.350-4

Special tool diameter d₁ = 16.350 -4 μm

Dimensions of configurable series IT6

d ₁	MK	l ₁	l ₂	l ₄	l ₅	z
2,800-3,000	1	113	15	47,5	42	6
3,001-3,350	1	117	16	51,5	46	6
3,351-3,750	1	120	18	54,5	49	6
3,751-4,250	1	124	19	58,5	53	6
4,251-4,750	1	128	21	62,5	57	6
4,751-5,300	1	133	23	67,5	58	6
5,301-6,050	1	138	26	72,5	64	6
6,051-6,700	1	144	28	78,5	70	6
6,701-7,500	1	150	31	84,5	76	6
7,501-8,500	1	156	33	90,5	83	6
8,501-9,500	1	162	36	96,5	90	6
9,501-10,600	1	168	38	102,5	96	6
10,601-11,800	1	175	41	109,5	105	6
11,801-13,200	1	182	44	116,5	112	6
13,201-14,100	1	189	47	123,5	119	8
14,101-15,100	2	204	50	124	117	8
15,101-16,100	2	210	52	130	124	8
16,101-17,100	2	214	54	134	129	8
17,101-18,100	2	219	56	139	134	8
18,101-19,100	2	223	58	143	138	8
19,101-20,100	2	228	60	148	143	8
20,101-21,200	2	232	62	152	147	8
21,201-22,400	2	237	64	157	152	8
22,401-23,600	2	241	66	161	156	8
23,601-25,100	3	268	68	169	164	8
25,101-26,500	3	273	70	174	169	8
26,501-28,100	3	277	71	178	173	10
28,101-30,100	3	281	73	182	177	10
30,101-31,500	3	285	75	186	181	10
31,501-33,500	4	317	77	193	188	10
33,501-35,500	4	321	78	197	191	10
35,501-37,500	4	325	79	201	195	10
37,501-40,100	4	329	81	205	199	10
40,101-42,500	4	333	82	209	204	12
42,501-45,100	4	336	83	212	206	12
45,101-47,500	4	340	84	216	210	12
47,501-50,100	4	344	86	220	214	12

Dimensions in mm.

For cutting data recommendations, see end of chapter.

Special designs and possible coatings available upon request.

Machine reamer | B033111

Fixed design with morse taper shank

Design:

Diameter: 9.510 - 20.100 mm
 Cutting direction: Right-hand cutting
 Cutting material: HSS-E, TiN-coated (SP344)
 Groove direction: Spiral fluted

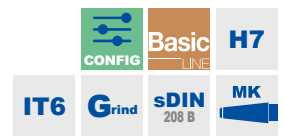
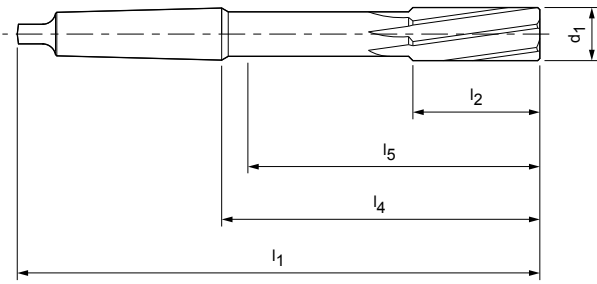

Preferred series in H7

Dimensions						z	Order no.
d ₁ H7	MK	l ₁	l ₂	l ₄	l ₅		
10,000	1	168	38	102,5	96	6	30107929
11,000	1	175	41	109,5	105	6	30107931
12,000	1	182	44	116,5	112	6	30107933
13,000	1	182	44	116,5	112	6	30107935
14,000	1	189	47	123,5	119	8	30107937
15,000	2	204	50	124	117	8	30107939
16,000	2	210	52	130	124	8	30107941
17,000	2	214	54	134	129	8	30107943
18,000	2	219	56	139	134	8	30107945
19,000	2	223	58	143	138	8	30107947
20,000	2	228	60	148	143	8	30107949

Configurable features

Bore diameter tolerance ≥ IT6:
 - Diameter in increments of 0.001 mm freely selectable
 - Can be ordered in tolerance ≥ IT6

Specification:
 B033111[**Diameter**][**Tolerance**]

G variant (see page 303):
 - Diameter in increments of 0.001 mm freely selectable
 - Can be ordered from tolerances ≥ 4 µm

G variant specification:
 B033111[**Diameter**][**Tolerance**]

Dimensions of configurable series IT6

d ₁	MK	l ₁	l ₂	l ₄	l ₅	z
9,501-10,600	1	168	38	102,5	96	6
10,601-11,800	1	175	41	109,5	105	6
11,801-13,200	1	182	44	116,5	112	6
13,201-14,100	1	189	47	123,5	119	8
14,101-15,100	2	204	50	124	117	8
15,101-16,100	2	210	52	130	124	8
16,101-17,100	2	214	54	134	129	8
17,101-18,100	2	219	56	139	134	8
18,101-19,100	2	223	58	143	138	8
19,101-20,100	2	228	60	148	143	8

IT6 tolerance example:
 B033111-Ø16.350H6

Bore diameter d₁ = 16.350 H6

G variant example:
 B033111-Ø16.350-4

Special tool diameter d₁ = 16.350 -4 µm

Dimensions in mm.
 For cutting data recommendations, see end of chapter.
 Special designs and possible coatings available upon request.

Reamer for automatic lathes | B030716

Fixed design, short design

Design:

Diameter:

3.750 - 20.200 mm

Cutting direction:

Right-hand cutting

Cutting material:

HSS-E, uncoated (SU344)

Groove direction:

spiral fluted

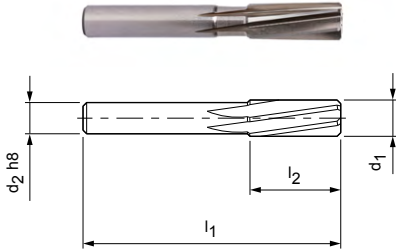

Preferred series in H7

Dimensions					z	Order no.
d ₁ H7	d ₂ h8	l ₁	l ₂	l ₃		
4,000	3,55	56	20	28	6	30105762
4,500	4	63	22	28	6	30105764
5,000	4	63	22	28	6	30105766
5,500	5	63	22	28	6	30105768
6,000	5	63	22	28	6	30105770
6,500	5	63	22	28	6	30105772
7,000	6,3	71	25	36	6	30105774
7,500	6,3	71	25	36	6	30105776
8,000	6,3	71	25	36	6	30105778
8,500	6,3	71	25	36	6	30105780
9,000	8	71	25	36	6	30105782
9,500	8	71	25	36	6	30105784
10,000	8	71	25	36	6	30105786
10,500	8	71	25	36	6	30105788
11,000	10	80	28	40	6	30105790
11,500	10	80	28	40	6	30105792
12,000	10	80	28	40	6	30105794
13,000	10	80	32	45	6	30105796
14,000	12,5	90	32	45	8	30105798
15,000	12,5	90	32	45	8	30105800
16,000	12,5	90	32	45	8	30105802
17,000	12,5	90	32	45	8	30105804
18,000	16	100	36	48	8	30105806
19,000	16	100	36	48	8	30105808
20,000	16	100	36	48	8	30105810

Continued on next page.

Configurable features



Bore diameter tolerance \geq IT6:
 - Diameter in increments of 0.001 mm freely selectable
 - Can be ordered in tolerance \geq IT6



Specification:
 B030716[Diameter][Tolerance]

G variant (see page 303):
 - Diameter in increments of 0.001 mm freely selectable
 - Can be ordered from tolerances $\geq 4 \mu\text{m}$

G variant specification:
 B030716[Diameter][Tolerance]

IT6 tolerance example:
 B030716-Ø16.350H6

Bore diameter $d_1 = 16.350 \text{ H6}$

G variant example:
 B030716-Ø16.350-4

Special tool diameter $d_1 = 16.350 -4 \mu\text{m}$

Dimensions of configurable series IT6

d_1	$d_2 \text{ h8}$	l_1	l_2	l_3	z
3,750-4,250	3,55	56	20	28	6
4,251-5,300	4	63	22	28	6
5,301-6,700	5	63	22	28	6
6,701-8,200	6,3	71	25	36	6
8,201-8,700 ⁽¹⁾	6,3	71	25	36	6
8,701-10,600	8	71	25	36	6
10,601-13,200	10	80	28	40	6
13,201-16,200	12,5	90	32	45	8
16,201-17,200 ⁽¹⁾	12,5	90	32	45	8
17,201-20,200	16	100	36	48	8

(1) Minimum deviation from the standard for manufacturing reasons

Helical machine reamer I B030610

Fixed design

Design:

Diameter: 0.950 - 20.000 mm
 Cutting direction: Right-hand cutting
 Cutting material: HSS-E, uncoated (SU344)
 Groove direction: Spiral fluted (approx. 45° left)

Special feature:

Up to \varnothing 3.50 mm: Not standardised, sim. DIN 212-1C.
 From \varnothing 4.00 mm: DIN 212-2C.

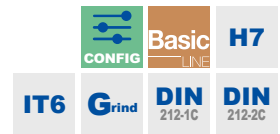
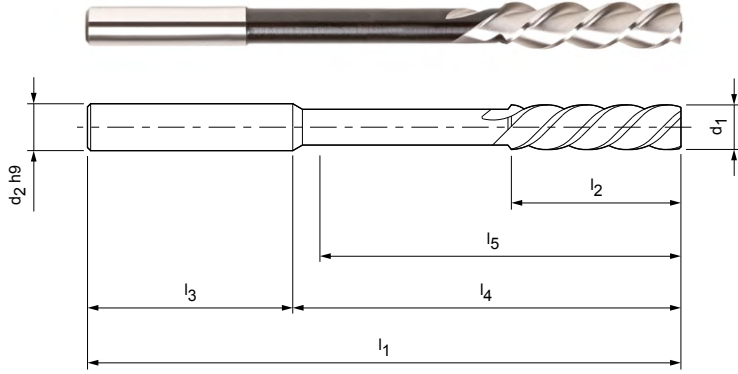
**Preferred series in H7**

Dimensions							z	Order no.
d_1 H7	d_2 h9	l_1	l_2	l_3	l_4	l_5		
1,000	1	34	5,5	19	15	9,5	2	30105682
1,100	1,1	36	6,5	20,5	15,5	10	2	30310927
1,200	1,2	38	7,5	21,5	16,5	10,5	2	30105683
1,400	1,4	40	8	22	18	12	2	30105684
1,500	1,5	40	8	22	18	12	2	30105685
1,600	1,6	43	9	23	20	13,5	2	30105686
1,800	1,8	46	10	24	22	15	2	30105687
2,000	2	49	11	25	24	17	3	30105688
2,200	2,2	53	12	28	25	18	3	30105689
2,500	2,5	57	14	28	29	22	3	30105700
3,000	3	61	15	28	33	25	3	30105702
3,200	3,2	65	16	28	37	29	3	30105703
3,500	3,5	70	18	28	42	34	3	30105704
4,000	4	75	19	28	47	39	3	30105705
4,500	4,5	80	21	28	52	42	3	30105707
5,000	5	86	23	28	58	48	3	30105709
5,500	5,6	93	26	36	57	46	3	30105711
6,000	5,6	93	26	36	57	46	3	30105713
6,500	6,3	101	28	36	65	54	3	30105715
7,000	7,1	109	31	36	73	61	3	30105717
7,500	7,1	109	31	36	73	61	3	30105719
8,000	8	117	33	36	81	67	3	30105721
8,500	8	117	33	36	81	67	3	30105723
9,000	9	125	36	40	85	70	3	30105725
9,500	9	125	36	40	85	70	3	30105727
10,000	10	133	38	40	93	78	3	30105729
11,000	10	142	41	40	102	86	3	30105731
12,000	10	151	44	40	111	94	3	30105733
13,000	10	151	44	40	111	93	3	30105735
14,000	12,5	160	47	45	115	97	3	30105737
15,000	12,5	162	50	45	117	98	3	30105739
16,000	12,5	170	52	45	125	106	3	30105741
17,000	14	175	54	45	130	110	3	30105743
18,000	14	182	56	45	137	117	3	30105745
19,000	16	189	58	48	141	120	3	30105747
20,000	16	195	60	48	147	126	3	30105749

Continued on next page.

Configurable features



Bore diameter tolerance \geq IT6:
 - Diameter in increments of 0.001 mm freely selectable
 - Can be ordered in tolerance \geq IT6



Specification:
 B030610[Diameter][Tolerance]

G variant (see page 303):
 - Diameter in increments of 0.001 mm freely selectable
 - Can be ordered from tolerances \geq 4 μ m

G variant specification:
 B030610[Diameter][Tolerance]

IT6 tolerance example:
 B030610- \emptyset 16.350H6

Bore diameter $d_1 = 16.350$ H6

G variant example:
 B030610- \emptyset 16.350-4

Special tool diameter $d_1 = 16.350 -4 \mu$ m

Dimensions of configurable series IT6

d_1	d_2 h9	l_1	l_2	l_3	l_4	l_5	z
0,950-1,060 ⁽¹⁾	1	34	5,5	19	15	9,5	2
1,061-1,180 ⁽¹⁾	1,1	36	6,5	20,5	15,5	10	2
1,181-1,320 ⁽¹⁾	1,2	38	7,5	21,5	16,5	10,5	2
1,321-1,410 ⁽¹⁾	1,4	40	8	22	18	12	2
1,411-1,500 ⁽¹⁾	1,5	40	8	22	18	12	2
1,501-1,700 ⁽¹⁾	1,6	43	9	23	20	13,5	2
1,701-1,900 ⁽¹⁾	1,8	46	10	24	22	15	2
1,901-2,120 ⁽¹⁾	2	49	11	25	24	17	3
2,121-2,360 ⁽¹⁾	2,2	53	12	28	25	18	3
2,361-2,650 ⁽¹⁾	2,5	57	14	28	29	22	3
2,651-3,030 ⁽¹⁾	3	61	15	28	33	25	3
3,031-3,350	3,2	65	16	28	37	29	3
3,351-3,750	3,5	70	18	28	42	34	3
3,751-4,250	4	75	19	28	47	39	3
4,251-4,750	4,5	80	21	28	52	42	3
4,751-5,300	5	86	23	28	58	48	3
5,301-5,600	5,6	93	26	36	57	46	3
5,601-6,030 ⁽²⁾	5,6	93	26	36	57	46	3
6,031-6,700	6,3	101	28	36	65	54	3
6,701-7,500	7,1	109	31	36	73	61	3
7,501-8,500	8	117	33	36	81	67	3
8,501-9,500	9	125	36	40	85	70	3
9,501-10,200	10	133	38	40	93	78	3
10,201-11,200	10	142	41	40	102	86	3
11,201-12,200	10	151	44	40	111	94	3
12,201-13,200	10	151	44	40	111	93	3
13,201-14,000	12,5	160	47	45	115	97	3
14,001-15,000	12,5	162	50	45	117	98	3
15,001-16,000	12,5	170	52	45	125	106	3
16,001-17,000	14	175	54	45	130	110	3
17,001-18,000	14	182	56	45	137	117	3
18,001-19,000	16	189	58	48	141	120	3
19,001-20,000	16	195	60	48	147	126	3

(1) $\leq d_1$ 3.000 mm only IT7 possible

(2) Minimal deviation from the standard for manufacturing reasons.

Helical machine reamer I B030310

Fixed design with morse taper shank

Design:

Diameter:

4.751 - 32.200 mm

Cutting direction:

Right-hand cutting

Cutting material:

HSS-E, uncoated (SU344)

Groove direction:

Spiral fluted (approx. 45° left)

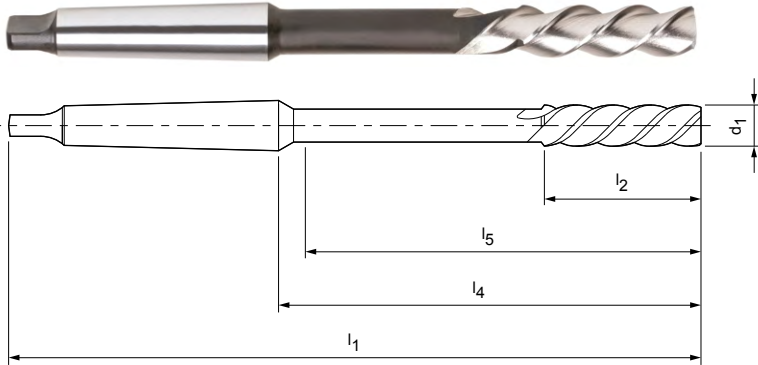

Preferred series in H7

Dimensions						z	Order no.
d ₁ H7	MK	l ₁	l ₂	l ₄	l ₅		
5,000	1	133	23	67,5	53	3	30102871
6,000	1	138	26	72,5	57	3	30102873
7,000	1	150	31	84,5	68	3	30102875
8,000	1	156	33	90,5	73	3	30102877
9,000	1	162	36	96,5	80	3	30102879
10,000	1	168	38	102,5	85	3	30102881
11,000	1	175	41	109,5	93	3	30102883
12,000	1	182	44	116,5	100	3	30102885
13,000	1	182	44	116,5	100	3	30102887
14,000	1	189	47	123,5	106	3	30102889
15,000	2	204	50	124	104	3	30102891
16,000	2	210	52	130	110	3	30102893
17,000	2	214	54	134	115	3	30102895
18,000	2	219	56	139	119	3	30102897
19,000	2	223	58	143	123	3	30102899
20,000	2	228	60	148	127	3	30102901
21,000	2	232	62	152	131	3	30102903
22,000	2	237	64	157	135	3	30102905
23,000	2	241	66	161	139	3	30102907
24,000	3	268	68	169	146	3	30102909
25,000	3	268	68	169	146	3	30102911
26,000	3	273	70	174	150	3	30102913
27,000	3	277	71	178	153	3	30102915
28,000	3	277	71	178	153	3	30102917
29,000	3	281	73	182	156	3	30102919
30,000	3	281	73	182	156	3	30102921
31,000	3	285	75	186	160	3	30102923
32,000	4	317	77	193	166	3	30102925

Continued on next page.

Configurable features



Bore diameter tolerance \geq IT6:
 - Diameter in increments of 0.001 mm freely selectable
 - Can be ordered in tolerance \geq IT6



Specification:
 B030310[Diameter][Tolerance]

G variant (see page 303):
 - Diameter in increments of 0.001 mm freely selectable
 - Can be ordered from tolerances \geq 4 μ m

G variant specification:
 B030310[Diameter][Tolerance]

IT6 tolerance example:
 B030310- \emptyset 16.350H6

Bore diameter $d_1 = 16.350$ H6

G variant example:
 B030310- \emptyset 16.350-4

Special tool diameter $d_1 = 16.350 - 4$ μ m

Dimensions of configurable series IT6

d_1	MK	l_1	l_2	l_4	l_5	z
4,751-5,300	1	133	23	67,5	53	3
5,301-6,050	1	138	26	72,5	57	3
6,051-6,700	1	144	28	78,5	63	3
6,701-7,500	1	150	31	84,5	68	3
7,501-8,500	1	156	33	90,5	73	3
8,501-9,500	1	162	36	96,5	80	3
9,501-10,600	1	168	38	102,5	85	3
10,601-11,800	1	175	41	109,5	93	3
11,801-13,200	1	182	44	116,5	100	3
13,201-14,100	1	189	47	123,5	106	3
14,101-15,100	2	204	50	124	104	3
15,101-16,100	2	210	52	130	110	3
16,101-17,100	2	214	54	134	115	3
17,101-18,100	2	219	56	139	119	3
18,101-19,100	2	223	58	143	123	3
19,101-20,100	2	228	60	148	127	3
20,101-21,200	2	232	62	152	131	3
21,201-22,400	2	237	64	157	135	3
22,401-23,600	2	241	66	161	139	3
23,601-25,100	3	268	68	169	146	3
25,101-26,500	3	273	70	174	150	3
26,501-28,100	3	277	71	178	153	3
28,101-30,100	3	281	73	182	156	3
30,101-31,500	3	285	75	186	160	3
31,501-32,200	4	317	77	193	166	3

Dimensions in mm.

For cutting data recommendations, see end of chapter.

Special designs and possible coatings available upon request.

Bridge reamer I B030010

Fixed design

Design:

Diameter: 6.400 - 40.000 mm
 Cutting direction: Right-hand cutting
 Cutting material: HSS, uncoated (SU344)
 Groove direction: Spiral fluted

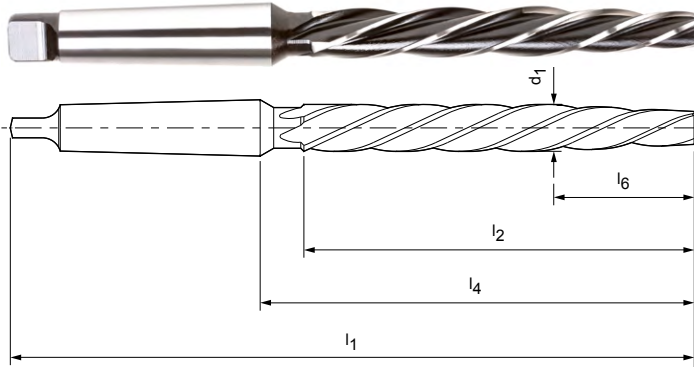
Special feature:Lead approx. taper 1:10 on lead length l_6 .**Preferred series available from stock in K11**

Dimensions						z	Order no.
d_1 k11	MK	l_1	l_2	l_4	l_6		
6,400	1	151	75	85,5	19	3	30102602
7,400	1	156	80	90,5	22	3	30102604
8,400	1	161	85	95,5	25	3	30102606
9,500	1	166	90	100,5	27	4	30102608
10,000	1	171	95	105,5	30	4	30102610
11,000	1	176	100	110,5	33	4	30102612
12,000	2	199	105	119	39	4	30102614
13,000	2	199	105	119	39	4	30102616
14,000	2	209	115	129	42	4	30102618
15,000	2	219	125	139	45	4	30102620
16,000	2	229	135	149	48	4	30102622
17,000	3	251	135	152	51	4	30102624
18,000	3	261	145	162	58	4	30102626
19,000	3	261	145	162	58	4	30102628
20,000	3	271	155	172	62	4	30102630
21,000	3	271	155	172	62	4	30102632
22,000	3	281	165	182	66	4	30102634
23,000	3	281	165	182	66	4	30102636
24,000	3	296	180	197	72	4	30102638
25,000	3	296	180	197	72	4	30102640
26,000	3	296	180	197	72	4	30102642
27,000	3	311	195	212	78	4	30102644
28,000	3	311	195	212	78	4	30102646
30,000	3	311	195	212	78	5	30102648
31,000	3	326	210	227	84	5	30102650
32,000	4	354	210	230	84	5	30102652
33,000	4	354	210	230	84	5	30102654
34,000	4	364	220	240	88	5	30102656
37,000	4	364	220	240	88	5	30102658
40,000	4	374	230	250	92	5	30102660

Dimensions in mm.

For cutting data recommendations, see end of chapter.

Special designs and possible coatings available upon request.

Machine reamer WN141 | B030810

Fixed design, machine end face reamer

Design:

Diameter:

2.200 - 12.200 mm

Cutting direction:

Right-hand cutting

Cutting material:

HSS-E, uncoated (SU344)

Groove direction:

Straight fluted

Special feature:

With front cut.

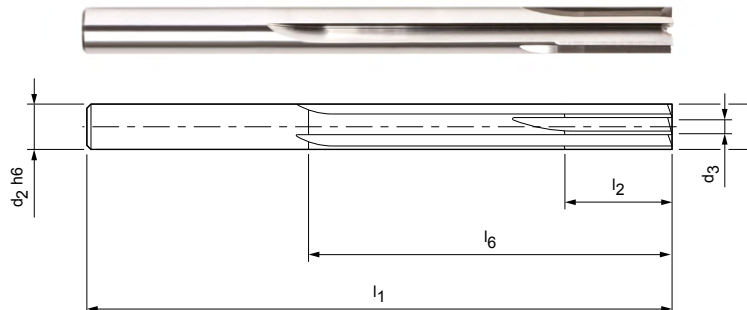

Preferred series in H7

Dimensions						z	Order no.
d ₁ H7	d ₂ h6	d ₃	l ₁	l ₂	l ₆		
2,500	2,5		57	12	33	4	30107503
3,000	3	1,5	61	12	33	6	30107504
3,500	3,5	1,5	70	12	39	6	30107505
4,000	4	1,7	75	16	44	6	30107506
4,500	4,5	1,7	80	16	48	6	30107508
5,000	5	1,7	86	20	53	6	30107510
5,500	5,5	2	93	20	59	6	30312212
6,000	6	2	93	20	59	6	30107512
6,500	6,5	2	101	20	65	6	30312214
7,000	7	2,5	109	22	69	6	30107514
7,500	7,5	2,5	109	22	69	6	30312215
8,000	8	3	117	24	71	6	30107516
8,500	8,5	3	117	24	71	6	30312216
9,000	9	3,5	125	24	77	6	30107518
9,500	9,5	3,5	125	24	77	6	30312232
10,000	10	4,5	133	26	84	6	30107520
11,000	11	4,5	142	26	89	6	30107522
12,000	12	4,5	151	26	96,5	6	30107524

Dimensions in mm.

For cutting data recommendations, see end of chapter.

Special designs and possible coatings available upon request.

Configurable features



Bore diameter tolerance \geq IT6:
 - Diameter in increments of 0.001 mm freely selectable
 - Can be ordered in tolerance \geq IT6



Specification:
 B030810[**Diameter**][**Tolerance**]

G variant (see page 303):
 - Diameter in increments of 0.001 mm freely selectable
 - Can be ordered from tolerances $\geq 4 \mu\text{m}$

G variant specification:
 B030810[**Diameter**][**Tolerance**]

IT6 tolerance example:
 B030810-**Ø11.350H6**

Bore diameter $d_1 = 11.350 \text{ H6}$

G variant example:
 B030810-**Ø11.350-4**

Special tool diameter $d_1 = 11.350 -4 \mu\text{m}$

Dimensions of configurable series IT6

d_1	$d_2 \text{ h6}$	d_3	l_1	l_2	l_6	z
2,200-2,690	2,5		57	12	33	4
2,691-3,100	3	1,5	61	12	33	6
3,101-3,650	3,5	1,5	70	12	39	6
3,651-4,200	4	1,7	75	16	44	6
4,201-4,700	4,5	1,7	80	16	48	6
4,701-5,200	5	1,7	86	20	53	6
5,201-5,700	5,5	2	93	20	59	6
5,701-6,110	6	2	93	20	59	6
6,111-6,700	6,5	2	101	20	65	6
6,701-7,200	7	2,5	109	22	69	6
7,201-7,630	7,5	2,5	109	22	69	6
7,631-8,200	8	3	117	24	71	6
8,201-8,630	8,5	3	117	24	71	6
8,631-9,200	9	3,5	125	24	77	6
9,201-9,630	9,5	3,5	125	24	77	6
9,631-10,200	10	4,5	133	26	84	6
10,201-11,200	11	4,5	142	26	89	6
11,201-12,220	12	4,5	151	26	96,5	6

Machine reamer WN142 | B030811

Facing reamer, machine end face reamer

Design:

Diameter:

2.690 - 32.200 mm

Cutting direction:

Right-hand cutting

Cutting material:

HSS-E, uncoated (SU344)

Groove direction:

Straight fluted

Special feature:

With front cut.

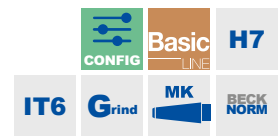
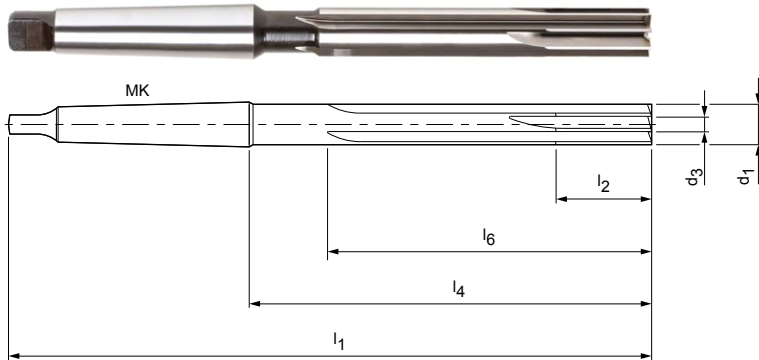
**Preferred series in H7**

Dimensions							z	Order no.
d ₁ H7	MK	d ₃	l ₁	l ₂	l ₄	l ₆		
3,000	1	1,5	114	12	48,5	33	6	30107526
3,500	1	1,5	120	12	54,5	39	6	30107527
4,000	1	1,7	124	16	58,5	44	6	30107528
4,500	1	1,7	128	16	62,5	48	6	30107530
5,000	1	1,7	133	20	67,5	53	6	30107532
5,500	1	2	138	20	72,5	59	6	30316948
6,000	1	2	138	20	72,5	59	6	30107534
6,500	1	2	144	20	78,5	65	6	30316951
7,000	1	2,5	150	22	84,5	69	6	30107536
7,500	1	2,5	150	22	84,5	69	6	30316954
8,000	1	3	156	24	90,5	71	6	30107538
8,500	1	3	156	24	90,5	71	6	30316955
9,000	1	3,5	162	24	96,5	77	6	30107540
9,500	1	3,5	162	24	96,5	77	6	30316957
10,000	1	4,5	168	26	102,5	84	6	30107542
10,500	1	4,5	168	26	102,5	84	6	30316958
11,000	1	4,5	175	26	109,5	89,5	6	30107544
11,500	1	4,5	175	26	109,5	89,5	6	30316959
12,000	1	4,5	182	26	116,5	96,5	6	30107546
13,000	1	4,5	182	26	116,5	96,5	6	30107548
14,000	1	5	189	28	123,5	103,5	8	30107550
15,000	2	5	204	28	124	104	8	30107552
16,000	2	6	210	30	130	108	8	30107554
17,000	2	6	214	30	134	112	8	30107556
18,000	2	6	219	30	139	117	8	30107558
19,000	2	8	223	32	143	119	8	30107560
20,000	2	8	228	32	148	124	8	30107562
21,000	2	8	232	32	152	128	8	30107564
22,000	2	10	237	34	157	133	8	30107566
24,000	3	10	268	34	169	139	8	30107568
25,000	3	12	268	36	169	139	8	30107570
26,000	3	12	273	36	174	144	8	30107572
27,000	3	14	277	38	178	148	10	30330852
28,000	3	14	277	38	178	148	10	30107574
29,000	3	14	281	42	182	150	10	30137427

Machine reamer WN 142 I B030811, fixed design Beck standard

Dimensions							z	Order no.
d ₁ H7	MK	d ₃	l ₁	l ₂	l ₄	l ₆		
30,000	3	16	281	42	182	150	10	30107576
31,000	3	16	285	44	186	154	10	30107578
32,000	4	16	317	44	193	157	10	30107579

Configurable features



Bore diameter tolerance ≥ IT6:
 - Diameter in increments of 0.001 mm freely selectable
 - Can be ordered in tolerance ≥ IT6



Specification:
 B030811[**Diameter**][**Tolerance**]

G variant (see page 303):
 - Diameter in increments of 0.001 mm freely selectable
 - Can be ordered from tolerances ≥ 4 μm

G variant specification:
 B030811[**Diameter**][**Tolerance**]

IT6 tolerance example:
 B030811-Ø16.350H6

Bore diameter d₁ = 16.350 H6

G variant example:
 B030811-Ø16.350-4

Special tool diameter d₁ = 16.350 -4 μm

Dimensions of configurable series IT6

d ₁	MK	d ₃	l ₁	l ₂	l ₄	l ₆	z
2,690-3,100 ⁽¹⁾	1	1,5	114	12	48,5	33	6
3,101-3,650	1	1,5	120	12	54,5	39	6
3,651-4,200	1	1,7	124	16	58,5	44	6
4,201-4,700	1	1,7	128	16	62,5	48	6
4,701-5,200	1	1,7	133	20	67,5	53	6
5,201-6,110	1	2	138	20	72,5	59	6
6,111-6,700	1	2	144	20	78,5	65	6
6,701-7,630	1	2,5	150	22	84,5	69	6
7,631-8,630	1	3	156	24	90,5	71	6
8,631-9,630	1	3,5	162	24	96,5	77	6
9,631-10,690	1	4,5	168	26	102,5	84	6
10,691-11,800	1	4,5	175	26	109,5	89,5	6
11,801-13,200	1	4,5	182	26	116,5	96,5	6
13,201-14,140	1	5	189	28	123,5	103,5	8
14,141-15,140	2	5	204	28	124	104	8
15,141-16,140	2	6	210	30	130	108	8
16,141-17,140	2	6	214	30	134	112	8
17,141-18,140	2	6	219	30	139	117	8
18,141-19,160	2	8	223	32	143	119	8
19,161-20,160	2	8	228	32	148	124	8
20,161-21,200	2	8	232	32	152	128	8
21,201-22,200	2	10	237	34	157	133	8
22,201-24,200	3	10	268	34	169	139	8
24,201-25,160	3	12	268	36	169	139	8
25,161-26,200	3	12	273	36	174	144	8
26,201-28,160	3	14	277	38	178	148	10
28,161-29,200	3	14	281	42	182	150	10
29,201-30,160	3	16	281	42	182	150	10
30,161-31,200	3	16	285	44	186	154	10
31,201-32,200	4	16	317	44	193	157	10

(1) ≤ d₁ 3.000 mm only IT7 possible

Dimensions in mm.

For cutting data recommendations, see end of chapter.

Special designs and possible coatings available upon request.

Hand reamer DIN 206 | B010011

Fixed design with cutting section, cylindrical shank and square end
(wrench size AF, see table)

Design:

Diameter:

0.950 - 60.200 mm

Cutting direction:

Right-hand cutting

Cutting material:

HSS (SU343)

Groove direction:

Spiral fluted

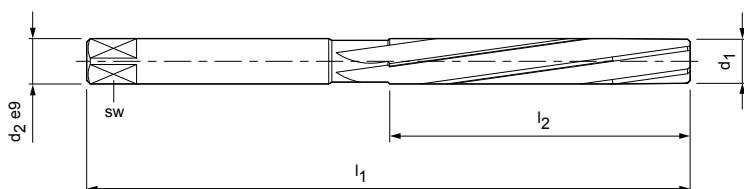
Preferred series in H7

Dimensions				AF	z	Order no.
d ₁ H7	d ₂ e9	l ₁	l ₂			
1,000	1	34	13		3	10070720
1,100	1,1	34	13		3	10070721
1,200	1,2	38	16		3	30611590
1,300	1,3	38	16		3	10070722
1,400	1,4	41	20	1,12	4	10070723
1,500	1,5	41	20	1,12	4	10070724
1,600	1,6	44	21	1,25	4	10070725
1,800	1,8	47	23	1,4	4	10070726
2,000	2	50	25	1,6	4	30101902
2,200	2,2	54	27	1,8	4	30101904
2,500	2,5	58	29	2,1	4	30101905
2,800	2,8	62	31	2,1	6	30101908
3,000	3	62	31	2,4	6	30101909
3,200	3,2	66	33	2,4	6	30345568
3,500	3,5	71	35	2,7	6	30101911
4,000	4	76	38	3	6	30101918
4,500	4,5	81	41	3,4	6	30101926
5,000	5	87	44	3,8	6	30101932
5,500	5,5	93	47	4,3	6	30101936
6,000	6	93	47	4,3	6	30101942
6,500	6,5	100	50	4,9	6	30101944
7,000	7	107	54	5,5	6	30101950
7,500	7,5	107	54	5,5	6	30101958
8,000	8	115	58	6,2	6	30101966
8,500	8,5	115	58	6,2	6	30101970
9,000	9	124	62	7	6	30101980
9,500	9,5	124	62	7	6	30101990
10,000	10	133	66	8	6	30101996
10,500	10,5	133	66	8	6	30101998
11,000	11	142	71	9	6	30102008
11,500	11,5	142	71	9	6	30102018
12,000	12	152	76	9	6	30102024
12,500	12,5	152	76	10	6	30102026
13,000	13	152	76	10	6	30102028
13,500	13,5	163	81	11	8	30102030

Hand reamer DIN 206 I B010011, fixed design

Dimensions				AF	z	Order no.
d ₁ H7	d ₂ e9	l ₁	l ₂			
14,000	14	163	81	11	8	30102032
14,500	14,5	163	81	12	8	30102034
15,000	15	163	81	12	8	30102036
15,500	15,5	175	87	12	8	30102038
16,000	16	175	87	12	8	30102040
16,500	16,5	175	87	13	8	30102042
17,000	17	175	87	13	8	30102044
17,500	17,5	188	93	14,5	8	30102046
18,000	18	188	93	14,5	8	30102048
18,500	18,5	188	93	14,5	8	30102050
19,000	19	188	93	14,5	8	30102052
19,500	19,5	201	100	16	8	30102054
20,000	20	201	100	16	8	30102056
21,000	21	201	100	16	8	30102058
22,000	22	215	107	18	8	30102060
23,000	23	215	107	18	8	30102062
24,000	24	231	115	18	8	30102064
25,000	25	231	115	20	8	30102066
26,000	26	231	115	20	8	30102068
27,000	27	247	124	22	10	30102070
28,000	28	247	124	22	10	30102072
29,000	29	247	124	22	10	30102074
30,000	30	247	124	22	10	30102076
31,000	31	265	133	24	10	30102078
32,000	32	265	133	24	10	30102080
33,000	33	265	133	26	10	30102082
34,000	34	284	142	26	10	30102084
35,000	35	284	142	26	10	30102086
36,000	36	284	142	29	10	30102088
37,000	37	284	142	29	10	30102090
38,000	38	305	152	29	10	30102092
39,000	39	305	152	29	10	30102094
40,000	40	305	152	32	10	30102096
45,000	45	326	163	35	12	30102100
50,000	50	347	174	39	12	30102103
60,000	60	367	184	49	12	30102105

Continued on next page.

Configurable features



Bore diameter tolerance \geq IT6:
 - Diameter in increments of 0.001 mm freely selectable
 - Can be ordered in tolerance \geq IT6



Specification:
 B010011[**Diameter**][**Tolerance**]

G variant (see page 303):
 - Diameter in increments of 0.001 mm freely selectable
 - Can be ordered from tolerances $\geq 4 \mu\text{m}$

G variant specification:
 B010011[**Diameter**][**Tolerance**]

IT6 tolerance example:
 B010011-**Ø16.350H6**

Bore diameter $d_1 = 16.350 \text{ H6}$

G variant example:
 B010011-**Ø16.350-4**

Special tool diameter $d_1 = 16.350 -4 \mu\text{m}$

Dimensions of configurable series IT6

d_1	l_1	l_2	sw	z
0,950 - 1,180	34	13	-	3
1,181 - 1,320	38	16	-	3
1,321 - 1,500	41	20	1,12	4
1,501 - 1,700	44	21	1,25	4
1,701 - 1,900	47	23	1,4	4
1,901 - 2,120	50	25	1,6	4
2,121 - 2,360	54	27	1,8	4
2,361 - 2,650	58	29	2,1	4
2,651 - 2,830	62	31	2,1	6
2,831 - 3,000	62	31	2,4	6
3,001 - 3,350	66	33	2,4	6
3,351 - 3,750	71	35	2,7	6
3,751 - 4,250	76	38	3	6
4,251 - 4,750	81	41	3,4	6
4,751 - 5,300	87	44	3,8	6
5,301 - 6,100	93	47	4,3	6
6,101 - 6,700	100	50	4,9	6
6,701 - 7,600	107	54	5,5	6
7,601 - 8,600	115	58	6,2	6
8,601 - 9,600	124	62	7	6
9,601 - 10,600	133	66	8	6
10,601 - 11,600	142	71	9	6
11,601 - 12,300	152	76	9	6
12,301 - 13,200	152	76	10	6
13,201 - 14,200	163	81	11	8
14,201 - 15,100	163	81	12	8
15,101 - 16,200	175	87	12	8
16,201 - 17,200	175	87	13	8
17,201 - 19,100	188	93	14,5	8
19,101 - 21,200	201	100	16	8
21,201 - 23,200	215	107	18	8
23,201 - 24,200	231	115	18	8
24,201 - 26,200	231	115	20	8
26,201 - 30,200	247	124	22	10
30,201 - 32,200	265	133	24	10
32,201 - 33,200	265	133	26	10
33,201 - 35,200	284	142	26	10
35,201 - 37,200	284	142	29	10
37,201 - 39,200	305	152	29	10
39,201 - 40,200	305	152	32	10
43,000 - 45,200	326	163	35	12
48,000 - 50,200	347	174	39	12
58,000 - 60,200	367	184	49	12

Hand reamer I B011010, B011011

Expanding design, adjustable with cutting section, cylindrical shank and square end (wrench size AF, see table)

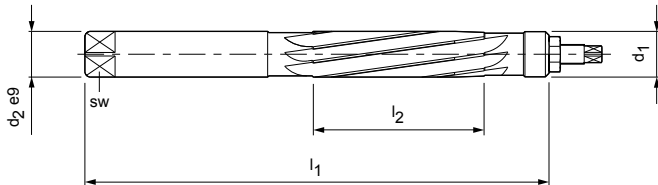

Design: **011010**
 Diameter: 4.000 - 5.500 mm
 Cutting direction: Right-hand cutting
 Cutting material: HSS (SU343)
 Groove direction: Straight fluted

Design: **011011**
 Diameter: 6.000 - 60.000 mm
 Cutting direction: Right-hand cutting
 Cutting material: HSS (SU343)
 Groove direction: Spiral fluted

Special feature:
 Adjustment range approx. 1/100 of d_1 .



Preferred series available from stock

Dimensions				AF	z	Order no.
d_1	$d_2 e9$	l_1	l_2			
4,000	4	76	24	3	6	30102107
4,500	4,5	81	27	3,4	6	30102109
5,000	5	87	30	3,8	6	30102111
5,500	5,5	93	33	4,3	6	30102113
6,000	6	93	33	4,9	6	30102239
6,500	6,5	100	34	4,9	6	30102241
7,000	7	107	38	5,5	9	30102243
7,500	7,5	107	38	6,2	9	30102245
8,000	8	115	42	6,2	9	30102247
8,500	8,5	115	42	7	9	30102249
9,000	9	124	46	7	9	30102251
9,500	9,5	124	46	8	9	30102253
10,000	10	133	50	8	9	30102255
10,500	10,5	133	50	8	9	30102257
11,000	11	142	51	9	9	30102259
11,500	11,5	142	51	9	9	30102261
12,000	12	152	56	9	9	30102263
12,500	12,5	152	56	10	9	30102265
13,000	13	152	56	10	9	30102267
13,500	13,5	163	61	11	9	30102269
14,000	14	163	61	11	9	30102271
14,500	14,5	163	61	11	9	30102273
15,000	15	163	61	12	9	30102275
15,500	15,5	175	67	12	9	30102277
16,000	16	175	67	12	9	30102279
16,500	16,5	175	67	13	9	30102281
17,000	17	175	67	13	9	30102283
17,500	17,5	188	68	14,5	9	30137431
18,000	18	188	68	14,5	9	30102285
18,500	18,5	188	68	14,5	9	30102286
19,000	19	188	68	14,5	9	30102288
19,500	19,5	201	75	16	9	30102289
20,000	20	201	75	16	9	30102291
21,000	21	201	75	16	9	30331489
22,000	22	215	82	18	12	30102293

Continued on next page.

Hand reamer, adjustable DIN 859 I B011011, expanding design

Dimensions				AF	z	Order no.
d ₁	d ₂ e9	l ₁	l ₂			
23,000	23	215	82	18	12	30331490
24,000	24	231	85	18	12	30102295
25,000	25	231	85	20	12	30102297
26,000	26	231	85	20	12	30102299
27,000	27	247	94	22	12	30102300
28,000	28	247	94	22	12	30102302
29,000	29	247	94	22	12	30102304
30,000	30	247	94	24	12	30102306
31,000	31	265	99	24	12	30102308
32,000	32	265	99	24	12	30102310
33,000	33	265	99	26	12	30331491
34,000	34	284	108	26	12	30102312
35,000	35	284	108	29	12	30102314
36,000	36	284	108	29	12	30102316
37,000	37	284	108	29	12	30331493
38,000	38	305	111	29	12	30102318
39,000	39	305	111	32	12	30102319
40,000	40	305	111	32	12	30102321
41,000	41	305	111	32	12	30102322
42,000	42	305	111	32	12	30331494
43,000	43	326	120	35	12	30331495
44,000	44	326	120	35	12	30331496
45,000	45	326	120	35	12	30102324
46,000	46	326	120	35	12	30102326
47,000	47	326	120	39	12	30331497
48,000	48	347	131	39	12	30331498
49,000	49	347	131	39	12	30102328
50,000	50	347	131	39	12	30102330
51,000	51	347	131	39	16	30331499
52,000	52	347	131	39	16	30331500
53,000	53	347	131	44	16	30331501
54,000	54	367	134	44	16	30331502
55,000	55	367	134	44	16	30102332
56,000	56	367	134	44	16	30331503
57,000	57	367	134	44	16	30331504
58,000	58	367	134	44	16	30102333
59,000	59	367	134	49	16	30331505
60,000	60	367	134	49	16	30102335

Configurable features



Bore diameter tolerance \geq IT6:
 - Diameter in increments of 0.001 mm freely selectable
 - Can be ordered in tolerance \geq IT6



Specification:
 B011010[Diameter][Tolerance]

G variant (see page 303):
 - Diameter in increments of 0.001 mm freely selectable
 - Can be ordered from tolerances $\geq 4 \mu\text{m}$

G variant specification:
 B011010[Diameter][Tolerance]

IT6 tolerance example:
 B011010-Ø16.350H6

Bore diameter $d_1 = 16.350 \text{ H6}$

G variant example:
 B011010-Ø16.350-4

Special tool diameter $d_1 = 16.350 -4 \mu\text{m}$

Dimensions of configurable series IT6

d_1	l_1	l_2	sw	z
3,900-4,200	76	24	3	6
4,201-4,700	81	27	3,4	6
4,701-5,200	87	30	3,8	6
5,201-6,200	93	33	4,3	6
6,201-6,700	100	34	4,9	6
6,701-7,200	107	38	5,5	9
7,201-7,630	107	38	6,2	9
7,631-8,200	115	42	6,2	9
8,201-8,630	115	42	7	9
8,631-9,200	124	46	7	9
9,201-9,630	124	46	8	9
9,631-10,600	133	50	8	9
10,601-11,800	142	51	9	9
11,801-12,400	152	56	9	9
12,401-13,200	152	56	10	9
13,201-14,640	163	61	11	9
14,641-15,140	163	61	12	9
15,141-16,140	175	67	12	9
16,141-17,140	175	67	13	9
17,141-19,160	188	68	14,5	9
19,161-21,200	201	75	16	9
21,201-23,200	215	82	18	12
23,201-24,200	231	85	18	12
24,201-26,200	231	85	20	12
26,201-29,200	247	94	22	12
29,201-30,200	247	94	24	12
30,201-32,200	265	99	24	12
32,201-33,200	265	99	26	12
33,201-34,200	284	108	26	12
34,201-37,200	284	108	29	12
37,201-38,200	305	111	29	12
38,201-32,200	305	111	32	12
42,201-46,200	326	120	35	12
46,201-47,200	326	120	39	12
47,201-50,200	347	131	39	12
50,201-52,200	347	131	39	16
52,201-53,200	347	131	44	16
53,201-58,200	367	134	44	16
58,201-60,200	367	134	49	16

Quick adjustment reamer WN 50 | B012011

With exchangeable blades, large adjustment range, especially suitable for repair work

Design:

Diameter:

Cutting direction:

Cutting material:

6.400 - 80.000 mm

Right-hand cutting

HSS (SU343)

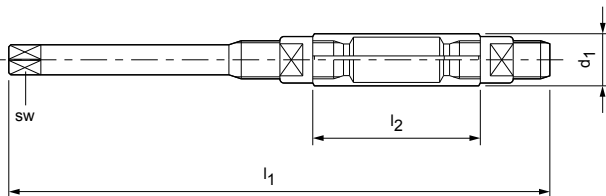

Preferred series available from stock

Dimensions						AF	z	Order no.
d ₁ ± 0.01	Size	∅ d ₁ -∅ d ₁ [mm]	∅ d ₁ -∅ d ₁ [inch]	l ₁	l ₂			
6,400	000	6,40-7,20	-	110	32	3	4	30102341
7,200	00	7,20-8,00	-	110	32	3,4	4	30102339
8,000	0	8,00-9,00	21/64-23/64	115	34	3,8	5	30102337
9,000	1	9,00-10,00	23/64-25/64	115	34	4,3	5	30102343
10,000	2	10,00-11,00	25/64-7/16	115	34	4,9	5	30102345
11,000	3	11,00-12,00	7/16-15/32	125	35	4,9	5	30102347
12,000	4	12,00-13,50	15/32-17/32	135	41	6,2	5	30102349
13,500	5	13,50-15,50	17/32-39/64	146	50	7	5	30102351
15,500	6	15,50-18,00	39/64-45/64	166	60	8	5	30102353
18,000	7	18,00-21,00	45/64-53/64	178	65	9	5	30102355
21,000	8	21,00-24,00	53/64-61/64	195	76	11	5	30102357
24,000	9	24,00-27,50	61/64-1 5/64	218	82	12	5	30102359
27,500	10	27,50-31,50	1 5/64-1 15/64	245	86	14,5	5	30102361
31,500	11	31,50-37,00	1 15/64-1 29/64	280	98	18	6	30102363
37,000	12	37,00-45,00	1 29/64-1 49/64	325	108	20	6	30102365
45,000	13	45,00-55,00	1 49/64-2 5/32	370	118	26	6	30102367
55,000	14	55,00-67,00	2 5/32-2 41/64	400	125	32	6	30102369
67,000	15	67,00-80,00	2 41/64-3 5/32	435	140	39	8	30102371
80,000	16	80,00-95,00	3 5/32-3 3/4	475	155	49	8	30102373

Sets quick adjustment reamer WN 50

Product code	Scope	Size	Area	Order no.
012015	11-part	0-10	8.000 - 31.500 mm	30135917
012016	13-part	0-12	8.000 - 45.000 mm	30135916

Spare blade sets I B012013

For quick adjustment reamer according to WN 50
Delivery only possible in sets.

Dimensions		z	Order no.
Size	l ₁		
000	32	4	30134531
00	32	4	30134519
0	34	5	30134496
1	34	5	30134534
2	34	5	30134535
3	35	5	30134536
4	41	5	30134537
5	50	5	30134538
6	60	5	30134539
7	65	5	30134540
8	76	5	30134541
9	82	5	30134542
10	86	5	30134543
11	98	6	30134544
12	108	6	30134545
13	118	6	30134546
14	125	6	30134547
15	140	8	30134548
16	155	8	30134549

Adjusting nuts I B012014

For quick adjustment reamer according to WN 50

Dimensions		Order no.
Size	M	
000	M5x0,75	10070246
00	M5,5x0,75	10070245
0	M6,5x0,75	10070244
1	M7x0,75	10070247
2	M7,5x0,75	10070248
3	M8x0,75	10070249
4	M9,5x1	10070250
5	M10,5x1	10070251
6	M12,5x1,25	10070252
7	M14,5x1,25	10070253
8	M16x1,25	10070254
9	M18x1,25	10070255
10	M22x1,5	10070256
11	M25x1,5	10070257
12	M30x1,5	10070258
13	M37x1,5	10070259
14	M46x1,5	10076837
15	M55x2	10076838
16	M68x2	10076839

Helical machine taper reamer I B021010

With taper 1:50 for reaming bores for taper pins according to DIN 1, DIN 258, DIN 7977 and DIN 7978 with cylindrical shank and driving element according to DIN 1809

Design:

Diameter:

Cutting direction:

Cutting material:

Groove direction:

1.000 - 12.000 mm

Right-hand cutting

HSS-E (SU344)

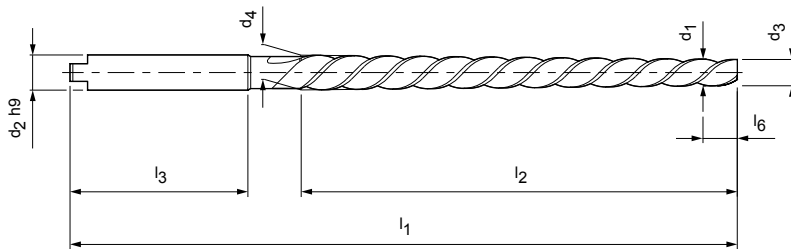
Spiral fluted with 45°
left-hand twist**Preferred series available from stock**

Dimensions								z	Order no.
d ₁	d ₂ h9	d ₃	d ₄	l ₁	l ₂	l ₃	l ₆		
1,000*	1,4	0,8	1,46	60	33	23	10	2	30102455
1,500*	2,1	1,4	2,14	70	37	29	5	2	30102456
2,000	3,15	1,9	2,86	86	48	29	5	3	30102457
2,500	3,15	2,4	3,36	86	48	29	5	3	30102458
3,000	4	2,9	4,06	100	58	32	5	3	30102459
4,000	5	3,9	5,26	112	68	34	5	3	30102461
5,000	6,3	4,9	6,36	122	73	38	5	3	30102463
6,000	8	5,9	8	160	105	42	5	3	30102465
6,500*	8,5	6,4	8,78	185	119	46	5	3	30102467
8,000	10	7,9	10,8	207	145	46	5	3	30102469
10,000	12,5	9,9	13,4	245	175	50	5	3	30102471
12,000	16	11,8	16	290	210	58	10	3	30102473

Dimensions in mm.

* Diameter not included in the standard.

Helical machine taper reamer I B021011

With taper 1:50 for reaming bores for taper pins according to DIN 1, DIN 258, DIN 7977 and DIN 7978 with morse taper shank

Design:

Diameter:

Cutting direction:

Cutting material:

Groove direction:

5.000 - 50.000 mm

Right-hand cutting

HSS-E (SU344)

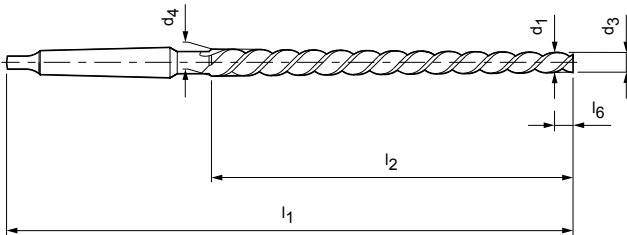
 Spiral fluted with 45°
left-hand twist

Preferred series available from stock

Dimensions							z	Order no.
d ₁	d ₃	d ₄	l ₁	l ₂	l ₆	MK		
5,000	4,9	6,36	155	73	5	1	3	30102475
6,000	5,9	8	187	105	5	1	3	30102477
8,000	7,9	10,8	227	145	5	1	3	30102479
10,000	9,9	13,4	257	175	5	1	3	30102481
12,000	11,8	16	315	210	10	2	3	30102483
13,000*	12,86	16,74	295	194	10	2	3	30102485
14,000*	13,86	17,74	295	194	10	2	3	30102487
16,000	15,8	20,4	335	230	10	2	3	30102489
20,000	19,8	24,8	377	250	10	3	3	30102491
25,000	24,7	30,7	427	300	15	3	3	30102493
30,000	29,7	36,1	475	320	15	4	4	30102495
40,000	39,7	46,5	495	340	15	4	6	30102497
50,000	49,7	56,9	550	360	15	5	8	30102499

Dimensions in mm.

* Diameter not included in the standard.

Hand taper reamer I B020011

Form B, with taper 1:50, with cylindrical shank and square end (wrench size AF, see table) for reaming bores for taper pins according to DIN 1, DIN 258, DIN 7977 and DIN 7978

Design:

Diameter:

Cutting direction:

Cutting material:

Groove direction:

3.000 - 50.000 mm

Right-hand cutting

HSS (SU343)

Spiral fluted

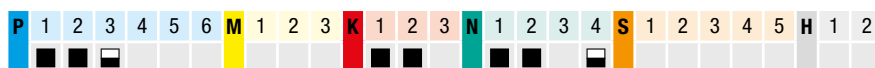
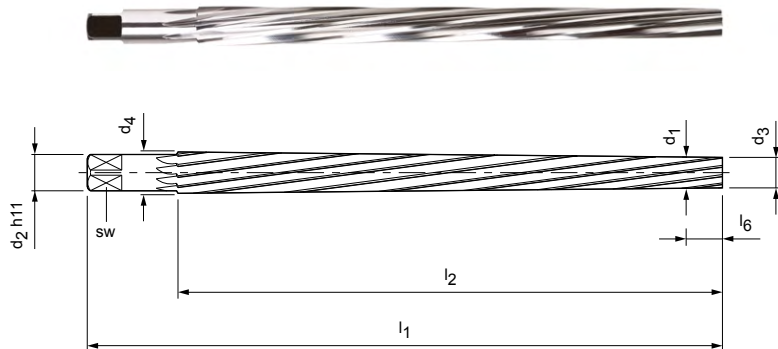
Preferred series available from stock

Dimensions							AF	z	Order no.
d ₁	d ₂ h11	d ₃	d ₄	l ₁	l ₂	l ₆			
3,000	4	2,9	4,06	80	58	5	3	5	30102415
3,500*	4,5	3,4	4,66	85	63	5	3,4	5	30102416
4,000	5	3,9	5,26	93	68	5	3,8	5	30102418
4,500*	5,6	4,4	5,8	95	70	5	4,3	5	30102420
5,000	6,3	4,9	6,36	100	73	5	4,9	5	30102422
5,500*	7,1	5,4	7,2	118	90	5	5,5	6	30102424
6,000	8	5,9	8	135	105	5	6,2	6	30102426
6,500*	8	6,4	8,6	140	110	5	6,2	6	30102428
7,000*	9	6,9	9,4	160	125	5	7	6	30102430
8,000	10	7,9	10,8	180	145	5	8	6	30102432
9,000*	11,2	8,9	12,1	195	160	5	9	6	30102434
10,000	12,5	9,9	13,4	215	175	5	10	6	30102436
12,000	14	11,8	16	255	210	10	11	8	30102438
13,000*	16	12,8	17	255	210	10	12	8	30102440
14,000*	16	13,8	18	255	210	10	12	8	30102442
16,000	18	15,8	20,4	280	230	10	14,5	8	30102444
20,000	22,4	19,8	24,8	310	250	10	18	8	30102446
25,000	28	24,7	30,7	370	300	15	22	10	30102448
30,000	31,5	29,7	36,1	400	320	15	24	10	30102450
40,000	40	39,7	46,5	430	340	15	32	12	30102452
50,000	50	49,7	56,9	460	360	15	39	12	30102454

Dimensions in mm.

* Diameter not included in the standard.

Hand taper reamer I B024011

Form A, with cylindrical shank and square end (width across flats (AF), see table), for finish-reaming of bores for morse taper

Design:

Cutting direction:

Right-hand cutting

Cutting material:

HSS (SU343)

Groove direction:

Straight fluted

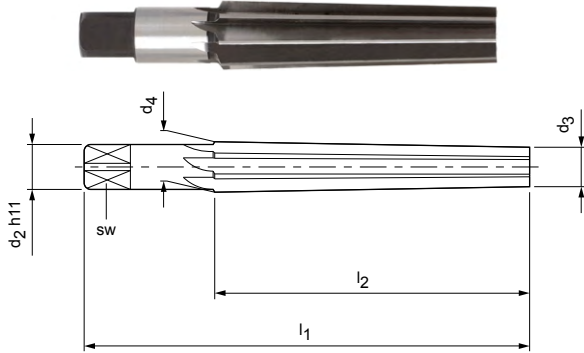
Preferred series available from stock

for MK	Dimensions					AF	z	Order no.
	d ₂ h11	d ₃	d ₄	l ₁	l ₂			
0	8	6,547	9,722	93	61	6,2	6	30102559
1	10	9,571	12,863	102	66	8	7	30102561
2	14	14,733	18,679	121	79	11	8	30102563
3	20	20,010	24,829	146	96	16	8	30102565
4	25	26,229	32,410	179	119	20	10	30102567
5	31,5	37,873	45,767	222	150	24	12	30102569
6	45	54,172	65,016	300	208	35	14	30102571

Shell reamer | B040910

Shell reamers with brazed blades

Design:

Diameter: 24.800 - 75.200 mm
 Cutting direction: Right-hand cutting
 Cutting material: Carbide, uncoated (HU613)
 Groove direction: Straight fluted

Special feature:

Clamping bore with taper 1:30 and cross slot according to DIN 138.

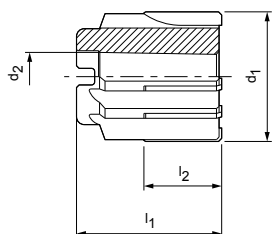

Preferred series in H7

Dimensions				z	Order no.
d_1 H7	d_2	l_1	l_2		
25,000	13	45	25	6	30110217
26,000	13	45	25	6	30168898
28,000	13	45	25	6	30200123
30,000	13	45	30	8	30110218
31,000	13	45	30	8	30264144
32,000	13	45	30	8	30110219
33,000	13	45	30	8	30271654
34,000	13	45	30	8	30110220
35,000	13	45	30	8	30110221
36,000	16	50	30	8	30110222
37,000	16	50	30	8	30110223
38,000	16	50	30	8	30110224
40,000	16	50	30	8	30110225
41,000	16	50	30	8	30284755
42,000	16	50	30	8	30110226
43,000	16	50	30	8	30250677
44,000	16	50	30	8	30110227
45,000	16	50	30	8	30110228
46,000	19	56	30	10	30263750
47,000	19	56	30	10	30241053
48,000	19	56	30	10	30110229
50,000	19	56	30	10	30110230
52,000	19	56	30	10	30110231
55,000	22	63	30	10	30110232
58,000	22	63	30	10	30110233
60,000	22	63	30	10	30110234
62,000	22	63	30	10	30217739
65,000	27	71	30	12	30205920
70,000	27	71	30	12	30110236
72,000	27	71	30	12	30110237
75,000	27	71	30	12	30110238

Configurable features



Bore diameter tolerance \geq IT6:
 - Diameter in a graduation of 0.001 mm freely selectable
 - Can be ordered in tolerance \geq IT6



Specification:
 B040910[Diameter][Tolerance]

G variant (see page 303):
 - Diameter in increments of 0.001 mm freely selectable
 - Can be ordered from tolerances $\geq 4 \mu\text{m}$

G variant specification:
 B040910[Diameter][Tolerance]

IT6 tolerance example:
 B040910-~~Ø~~39.350H6

Bore diameter $d_1 = 39.350 \text{ H6}$

G variant example:
 B040910-~~Ø~~39.350-4

Special tool diameter $d_1 = 39.350 -4 \mu\text{m}$

Dimensions of configurable series IT6

d_1	d_2^*	l_1^*	l_e^*	z
24,800-26,200	13	45	25	6
26,500-28,200	13	45	25	6
29,500-32,200	13	45	30	8
32,500-35,200	13	45	30	8
35,500-38,200	16	50	30	8
39,500-42,200	16	50	30	8
42,500-45,200	16	50	30	8
45,500-48,200	19	56	30	10
49,500-52,200	19	56	30	10
52,500-55,200	22	63	30	10
55,500-58,200	22	63	30	10
59,500-62,200	22	63	30	10
69,500-72,200	27	71	30	12
72,500-75,200	27	71	30	12

* Intermediate diameters that are not covered by the \varnothing ranges listed can be custom made on request.

Dimensions in mm.

d_2 = nominal diameter d_1 of the matching shell holder.

For cutting data recommendations, see end of chapter.

Shell reamer | B031211

Shell reamer

Design:

Diameter: 24.200 - 100.200 mm
 Cutting direction: Right-hand cutting
 Cutting material: HSS-E, uncoated (SU344)
 Groove direction: Spiral fluted

Special feature:

Clamping bore with taper 1:30 and cross slot according to DIN 138.

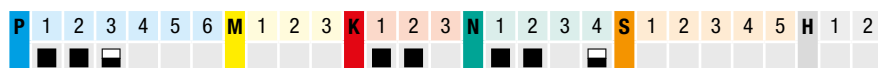
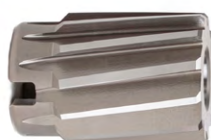
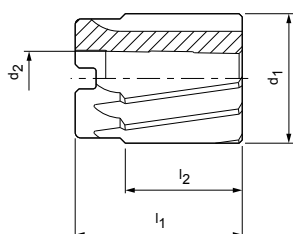
**Preferred series in H7**

Dimensions				z	Order no.
d_1 H7	d_2	l_1	l_2		
25,000	13	45	32	8	30107691
26,000	13	45	32	8	30107693
27,000	13	45	32	8	30107695
28,000	13	45	32	8	30107697
29,000	13	45	32	8	30107699
30,000	13	45	32	8	30107701
31,000	16	50	36	10	30107703
32,000	16	50	36	10	30107705
33,000	16	50	36	10	30107707
34,000	16	50	36	10	30107709
35,000	16	50	36	10	30107711
36,000	19	56	40	10	30107713
37,000	19	56	40	10	30107715
38,000	19	56	40	10	30107717
39,000	19	56	40	10	30331334
40,000	19	56	40	10	30107720
41,000	19	56	40	10	30331335
42,000	19	56	40	10	30107722
43,000	22	63	45	12	30243223
44,000	22	63	45	12	30107724
45,000	22	63	45	12	30107726
46,000	22	63	45	12	30107728
47,000	22	63	45	12	30107730
48,000	22	63	45	12	30107732
49,000	22	63	45	12	30331336
50,000	22	63	45	12	30107734
51,000	27	71	50	12	30331337
52,000	27	71	50	12	30107736
53,000	27	71	50	12	30209556
54,000	27	71	50	12	30306651
55,000	27	71	50	12	30107738
56,000	27	71	50	12	30209557
57,000	27	71	50	12	30331338
58,000	27	71	50	12	30107740
59,000	27	71	50	12	30562201

Shell reamer I B031211, clamping bore with taper 1:30 and cross slot according to DIN 138

Dimensions				z	Order no.
d ₁ H7	d ₂	l ₁	l ₂		
60,000	27	71	50	12	30107742
61,000	32	80	56	14	30331432
62,000	32	80	56	14	30107744
63,000	32	80	56	14	30331433
64,000	32	80	56	14	30331434
65,000	32	80	56	14	30107746
66,000	32	80	56	14	30528877
67,000	32	80	56	14	30562204
68,000	32	80	56	14	30107748
69,000	32	80	56	14	30331441
70,000	32	80	56	14	30107750
72,000	40	90	63	14	30107752
73,000	40	90	63	14	30331443
74,000	40	90	63	14	30331444
75,000	40	90	63	14	30107754
76,000	40	90	63	14	30216490
78,000	40	90	63	14	30107756
80,000	40	90	63	14	30107758
82,000	40	90	63	14	30107760
83,000	40	90	63	14	30331446
84,000	40	90	63	14	30331447
85,000	40	90	63	14	30107762
86,000	50	100	71	16	30331449
87,000	50	100	71	16	30331450
88,000	50	100	71	16	30107764
90,000	50	100	71	16	30107766
92,000	50	100	71	16	30107768
94,000	50	100	71	16	30403707
95,000	50	100	71	16	30107770
96,000	50	100	71	16	30331451
98,000	50	100	71	16	30107772
100,000	50	100	71	16	30107774

Continued on next page.

Configurable features

**Bore diameter tolerance \geq IT6:**

- Diameter in increments of 0.001 mm freely selectable
- Can be ordered in tolerance \geq IT6

**Specification:**B031211[**Diameter**][**Tolerance**]**G variant** (see page 303):

- Diameter in increments of 0.001 mm freely selectable
- Can be ordered from tolerances $\geq 4 \mu\text{m}$

G variant specification:B031211[**Diameter**][**Tolerance**]**IT6 tolerance example:**B031211-**Ø52.255H6**Bore diameter $d_1 = 52.255 \text{ H6}$ **G variant example:**B031211-**Ø52.255-4**Special tool diameter $d_1 = 52.255 -4 \mu\text{m}$

Dimensions of configurable series IT6

d_1	d_2^*	l_1^*	l_2^*	z
24,200-28,200	13	45	32	8
28,201-30,200 ⁽¹⁾	13	45	32	8
30,201-35,200	16	50	36	10
35,201-36,200 ⁽¹⁾	19	56	40	10
36,201-42,200	19	56	40	10
42,201-44,200 ⁽¹⁾	22	63	45	12
44,201-50,200	22	63	45	12
50,201-52,200 ⁽¹⁾	27	71	50	12
52,201-58,200	27	71	50	12
58,201-60,200 ⁽¹⁾	27	71	50	12
60,201-70,200	32	80	56	14
71,201-72,200 ⁽¹⁾	40	90	63	14
72,201-82,200	40	90	63	14
82,201-85,200 ⁽¹⁾	40	90	63	14
86,000-90,200	50	100	71	16
91,000-95,200	50	100	71	16
96,000-100,200	50	100	71	16

* Intermediate diameters that are not covered by the \varnothing ranges listed can be custom made on request!

(1) Minimum deviation from the standard for manufacturing reasons

Dimensions in mm.

 d_2 = nominal diameter d_1 of the matching shell holder.

For cutting data recommendations, see end of chapter.

Shell holder I B031610, B031611, B031612

Taper 1:30 with drive ring and release nut for shell reamers according to DIN 219, DIN 8054 and for shell core drills according to DIN 222

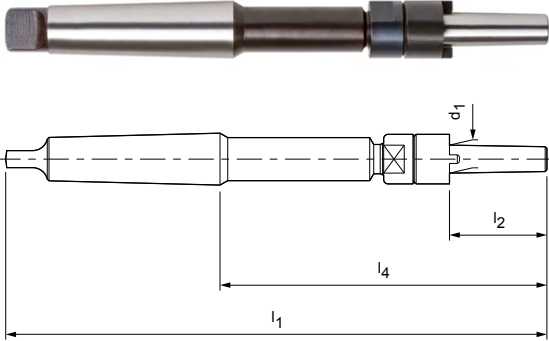

Preferred series available from stock

Dimensions								031610	031611	031612
d ₁	DIN 219	DIN 8054	DIN 222	l ₁	l ₂	l ₄	MK	Order no.	Order no.	Order no.
13,000	25-30	25-35	24-35	250	45	151	3	30107905		
16,000	31-35	36-45	36-45	261	50	162	3	30107907		
19,000	36-42	46-52	46-53	298	56	174	4	30107909		
19,000	36-42	46-52	46-53	273	56	174	3		30107921	
22,000	43-50	53-62	54-63	312	63	188	4	30107911		
22,000	43-50	53-62	54-63	287	63	188	3		30107923	
27,000	51-60	63-75	64-75	359	71	203	5	30107913		
27,000	51-60	63-75	64-75	327	71	203	4			30107925
32,000	61-71		76-90	376	80	220	5	30107915		
32,000	61-71		76-90	344	80	220	4			30107927
40,000	72-85		91-100	396	90	240	5	30107917		
50,000	86-100			416	100	260	5	30107919		

The following spare parts are also available from stock:

Driving rings I 031511

Release nuts I 031512

Washers I 031513

Cutting data recommendations for NC reamers

Feed f [mm/U], cutting speed v_c [m/min] and stock removal a [mm]

NC reamers

Cutting material: Carbide, uncoated, without internal coolant supply

ZG*		Workpiece material	Strength/hardness [N/mm ²] [HRC]
P	P1	P1.1 Structural, machining, case hardened and tempering steels, unalloyed	< 700 N/mm ²
		P1.2 Structural, machining, case hardened and tempering steels, unalloyed	< 1200 N/mm ²
	P2	P2.1 Nitriding, hardening and tempering steels, alloyed	< 900 N/mm ²
		P2.2 Nitriding, case-hardening and tempering steels, alloyed	< 1400 N/mm ²
	P3	P3.1 Tool steels, roller bearing steels, spring steels and high-speed steels	< 900 N/mm ²
		P3.2 Tool steels, roller bearing steels, spring steels and high-speed steels	< 1500 N/mm ²
	P5	P5.1 Cast steel	
K	K1	K1.1 Cast iron with lamellar graphite (grey cast iron), GJL	< 300 N/mm ²
		K2.1 Cast iron with spheroidal graphite, GJS	< 500 N/mm ²
	K2	K2.2 Cast iron with spheroidal graphite, GJS	500-800 N/mm ²
		K2.3 Cast iron with spheroidal graphite, GJS	> 800 N/mm ²
	K3	K3.1 Cast iron with vermicular graphite, GJV; malleable cast iron, GJM	< 500 N/mm ²
		K3.2 Cast iron with vermicular graphite, GJV; malleable cast iron, GJM	> 500 N/mm ²
N	N1	N1.1 Aluminium, unalloyed and alloyed < 3% Si	
		N1.2 Aluminium, alloyed \leq 7% Si	
	N2	N2.1 Copper, unalloyed and low alloyed	< 300 N/mm ²
		N2.2 Copper, alloyed	> 300 N/mm ²
		N2.3 Brass, bronze, gunmetal	< 1200 N/mm ²
	N4	N4.1 Plastic, thermoplastics	
		N4.2 Plastic, duroplastics	
		N4.3 Plastic, foam materials	

	<5 [mm]			>5 - 8 [mm]			>8 - 12 [mm]			>12 - 16 [mm]			>16 - 30 [mm]			>30 - 50 [mm]		
	v _c	f	a	v _c	f	a	v _c	f	a	v _c	f	a	v _c	f	a	v _c	f	a
	20	0.10	0.10	20	0.15	0.15	20	0.20	0.20	20	0.25	0.20	20	0.30	0.30	20	0.40	0.30
	12	0.10	0.10	12	0.15	0.15	12	0.20	0.20	12	0.25	0.20	12	0.30	0.30	12	0.40	0.30
	15	0.10	0.10	15	0.15	0.15	15	0.20	0.20	15	0.25	0.20	15	0.30	0.30	15	0.40	0.30
	12	0.10	0.10	12	0.15	0.15	12	0.20	0.20	12	0.25	0.20	12	0.30	0.30	12	0.40	0.30
	15	0.10	0.10	15	0.15	0.15	15	0.20	0.20	15	0.25	0.20	15	0.30	0.30	15	0.40	0.30
	12	0.10	0.10	12	0.15	0.15	12	0.20	0.20	12	0.25	0.20	12	0.30	0.30	12	0.40	0.30
	15	0.10	0.10	15	0.15	0.15	15	0.20	0.20	15	0.25	0.20	15	0.30	0.30	15	0.40	0.30
	18	0.10	0.10	18	0.20	0.15	18	0.30	0.20	18	0.30	0.20	18	0.40	0.30	18	0.50	0.30
	15	0.10	0.10	15	0.20	0.15	15	0.30	0.20	15	0.30	0.20	15	0.40	0.30	15	0.50	0.30
	10	0.10	0.10	10	0.20	0.15	10	0.30	0.20	10	0.30	0.20	10	0.40	0.30	10	0.50	0.30
	10	0.10	0.10	10	0.20	0.15	10	0.30	0.20	10	0.30	0.20	10	0.40	0.30	10	0.50	0.30
	15	0.10	0.10	15	0.20	0.15	15	0.30	0.20	15	0.30	0.20	15	0.40	0.30	15	0.50	0.30
	10	0.10	0.10	10	0.20	0.15	10	0.30	0.20	10	0.30	0.20	10	0.40	0.30	10	0.50	0.30
	40	0.15	0.10	40	0.20	0.15	40	0.25	0.20	40	0.30	0.20	40	0.40	0.30	40	0.50	0.30
	25	0.15	0.10	25	0.20	0.15	25	0.25	0.20	25	0.30	0.20	25	0.40	0.30	25	0.50	0.30
	30	0.15	0.10	30	0.20	0.15	30	0.25	0.20	30	0.30	0.20	30	0.40	0.30	30	0.50	0.30
	30	0.15	0.10	30	0.20	0.15	30	0.25	0.20	30	0.30	0.20	30	0.40	0.30	30	0.50	0.30
	30	0.15	0.10	30	0.20	0.15	30	0.25	0.20	30	0.30	0.20	30	0.40	0.30	30	0.50	0.30
	40	0.15	0.10	40	0.20	0.15	40	0.25	0.20	40	0.30	0.20	40	0.40	0.30	40	0.50	0.30
	40	0.15	0.10	40	0.20	0.15	40	0.25	0.20	40	0.30	0.20	40	0.40	0.30	40	0.50	0.30
	40	0.15	0.10	40	0.20	0.15	40	0.25	0.20	40	0.30	0.20	40	0.40	0.30	40	0.50	0.30
	40	0.15	0.10	40	0.20	0.15	40	0.25	0.20	40	0.30	0.20	40	0.40	0.30	40	0.50	0.30

The specified cutting data are guide values.

The optimum data for the respective machining task should be determined during the test or machining.

Cutting data recommendations for machine reamers

Feed f [mm/U], cutting speed v_c [m/min] and stock removal a [mm]

Machine reamers

Cutting material: HSS-E, uncoated and HSS-E, coated, without internal coolant supply

ZG*		Workpiece material	Strength/hardness [N/mm ²] [HRC]
P	P1	P1.1 Structural, machining, case hardened and tempering steels, unalloyed	< 700 N/mm ²
		P1.2 Structural, machining, case hardened and tempering steels, unalloyed	< 1200 N/mm ²
	P2	P2.1 Nitriding, hardening and tempering steels, alloyed	< 900 N/mm ²
		P2.2 Nitriding, case-hardening and tempering steels, alloyed	< 1400 N/mm ²
	P3	P3.1 Tool steels, roller bearing steels, spring steels and high-speed steels	< 900 N/mm ²
		P3.2 Tool steels, roller bearing steels, spring steels and high-speed steels	< 1500 N/mm ²
K	K1	K1.1 Cast iron with lamellar graphite (grey cast iron), GJL	< 300 N/mm ²
		K2.1 Cast iron with spheroidal graphite, GJS	< 500 N/mm ²
	K2	K2.2 Cast iron with spheroidal graphite, GJS	500-800 N/mm ²
		K2.3 Cast iron with spheroidal graphite, GJS	> 800 N/mm ²
	K3	K3.1 Cast iron with vermicular graphite, GJV; malleable cast iron, GJM	< 500 N/mm ²
		K3.2 Cast iron with vermicular graphite, GJV; malleable cast iron, GJM	> 500 N/mm ²
N	N1	N1.1 Aluminium, unalloyed and alloyed < 3% Si	
		N2.1 Copper, unalloyed and low alloyed	< 300 N/mm ²
	N2	N2.2 Copper, alloyed	> 300 N/mm ²
		N2.3 Brass, bronze, gunmetal	< 1200 N/mm ²
	N4	N4.1 Plastic, thermoplastics	
		N4.2 Plastic, duroplastics	
		N4.3 Plastic, foam materials	

	<5 [mm]			>5 - 8 [mm]			>8 - 12 [mm]			>12 - 16 [mm]			>16 - 30 [mm]			>30 - 50 [mm]		
	v _c	f	a	v _c	f	a	v _c	f	a	v _c	f	a	v _c	f	a	v _c	f	a
	12	0.10	0.10	12	0.15	0.15	12	0.20	0.20	12	0.25	0.20	12	0.30	0.30	12	0.40	0.30
	10	0.10	0.10	10	0.15	0.15	10	0.20	0.20	10	0.25	0.20	10	0.30	0.30	10	0.40	0.30
	12	0.10	0.10	12	0.15	0.15	12	0.20	0.20	12	0.25	0.20	12	0.30	0.30	12	0.40	0.30
	10	0.10	0.10	10	0.15	0.15	10	0.20	0.20	10	0.25	0.20	10	0.30	0.30	10	0.40	0.30
	12	0.10	0.10	12	0.15	0.15	12	0.20	0.20	12	0.25	0.20	12	0.30	0.30	12	0.40	0.30
	10	0.10	0.10	10	0.15	0.15	10	0.20	0.20	10	0.25	0.20	10	0.30	0.30	10	0.40	0.30
	12	0.15	0.10	12	0.20	0.15	12	0.25	0.20	12	0.30	0.20	12	0.35	0.30	12	0.40	0.30
	10	0.15	0.10	10	0.20	0.15	10	0.25	0.20	10	0.30	0.20	10	0.35	0.30	10	0.40	0.30
	10	0.15	0.10	10	0.20	0.15	10	0.25	0.20	10	0.30	0.20	10	0.35	0.30	10	0.40	0.30
	10	0.15	0.10	10	0.20	0.15	10	0.25	0.20	10	0.30	0.20	10	0.35	0.30	10	0.40	0.30
	10	0.15	0.10	10	0.20	0.15	10	0.25	0.20	10	0.30	0.20	10	0.35	0.30	10	0.40	0.30
	10	0.15	0.10	10	0.20	0.15	10	0.25	0.20	10	0.30	0.20	10	0.35	0.30	10	0.40	0.30
	15	0.15	0.10	15	0.20	0.15	15	0.20	0.20	15	0.25	0.20	15	0.30	0.30	15	0.40	0.30
	20	0.15	0.10	20	0.20	0.15	20	0.20	0.20	20	0.25	0.20	20	0.30	0.30	20	0.40	0.30
	20	0.15	0.10	20	0.20	0.15	20	0.20	0.20	20	0.25	0.20	20	0.30	0.30	20	0.40	0.30
	20	0.15	0.10	20	0.20	0.15	20	0.20	0.20	20	0.25	0.20	20	0.30	0.30	20	0.40	0.30
	25	0.15	0.10	25	0.20	0.15	25	0.20	0.20	25	0.25	0.20	25	0.30	0.30	25	0.40	0.30
	25	0.15	0.10	25	0.20	0.15	25	0.20	0.20	25	0.25	0.20	25	0.30	0.30	25	0.40	0.30
	25	0.15	0.10	25	0.20	0.15	25	0.20	0.20	25	0.25	0.20	25	0.30	0.30	25	0.40	0.30

The specified cutting data are guide values.

The optimum data for the respective machining task should be determined during the test or machining.

Cutting data recommendations for shell reamers

Feed f [mm/U], cutting speed v_c [m/min] and stock removal a [mm]

Shell reamers

Cutting material: Carbide, uncoated, without internal coolant supply

ZG*		Workpiece material	Strength/hardness [N/mm ²] [HRC]
P	P1	P1.1 Structural, machining, case hardened and tempering steels, unalloyed	< 700 N/mm ²
		P1.2 Structural, machining, case hardened and tempering steels, unalloyed	< 1200 N/mm ²
	P2	P2.1 Nitriding, hardening and tempering steels, alloyed	< 900 N/mm ²
		P2.2 Nitriding, case-hardening and tempering steels, alloyed	< 1400 N/mm ²
	P3	P3.1 Tool steels, roller bearing steels, spring steels and high-speed steels	< 900 N/mm ²
		P3.2 Tool steels, roller bearing steels, spring steels and high-speed steels	< 1500 N/mm ²
	P5	P5.1 Cast steel	
M	M1	M1.1 Stainless steels, austenitic	< 700 N/mm ²
		M1.2 Stainless steels, ferritic/austenitic (Duplex)	< 1000 N/mm ²
	M2	M2.1 Stainless cast steel, austenitic	< 700 N/mm ²
	M3	M3.1 Stainless cast steel, ferritic/austenitic (Duplex)	< 1000 N/mm ²
K	K1	K1.1 Cast iron with lamellar graphite (grey cast iron), GJL	< 300 N/mm ²
		K2.1 Cast iron with spheroidal graphite, GJS	< 500 N/mm ²
	K2	K2.2 Cast iron with spheroidal graphite, GJS	500-800 N/mm ²
		K2.3 Cast iron with spheroidal graphite, GJS	> 800 N/mm ²
	K3	K3.1 Cast iron with vermicular graphite, GJV; malleable cast iron, GJM	< 500 N/mm ²
		K3.2 Cast iron with vermicular graphite, GJV; malleable cast iron, GJM	> 500 N/mm ²
S	S1	S1.1 Titanium, titanium alloys	< 400 N/mm ²
		S2.1 Titanium, titanium alloys	< 1200 N/mm ²
	S2	S2.2 Titanium, titanium alloys	> 1200 N/mm ²
		S3.1 Nickel, unalloyed and alloyed	< 900 N/mm ²
	S3	S3.2 Nickel, unalloyed and alloyed	> 900 N/mm ²
		S4	S4.1 High-temperature super alloy, Ni-, Co-, and Fe-based
	S5	S5.1 Molybdenum and tungsten alloys	
H	H1	H1.1 Hardened steel/cast steel	45-55 HRC
		H1.2 Hardened steel/cast steel	55-64 HRC
	H2	H2.3 Wear-resistant cast / chill casting, GJN	

	<5 [mm]			>5 - 8 [mm]			>8 - 12 [mm]			>12 - 16 [mm]			>16 - 30 [mm]			>30 - 50 [mm]		
	v _c	f	a	v _c	f	a	v _c	f	a	v _c	f	a	v _c	f	a	v _c	f	a
	30	0.10	0.10	30	0.15	0.10	30	0.20	0.20	30	0.25	0.20	30	0.30	0.30	30	0.40	0.30
	15	0.10	0.10	15	0.15	0.10	15	0.20	0.20	15	0.25	0.20	15	0.30	0.30	15	0.40	0.30
	25	0.10	0.10	25	0.15	0.10	25	0.20	0.20	25	0.25	0.20	25	0.30	0.30	25	0.40	0.30
	15	0.10	0.10	15	0.15	0.10	15	0.20	0.20	15	0.25	0.20	15	0.30	0.30	15	0.40	0.30
	25	0.10	0.10	25	0.15	0.10	25	0.20	0.20	25	0.25	0.20	25	0.30	0.30	25	0.40	0.30
	15	0.10	0.10	15	0.15	0.10	15	0.20	0.20	15	0.25	0.20	15	0.30	0.30	15	0.40	0.30
	25	0.10	0.10	25	0.15	0.10	25	0.20	0.20	25	0.25	0.20	25	0.30	0.30	25	0.40	0.30
	15	0.08	0.08	15	0.10	0.10	15	0.15	0.10	15	0.20	0.20	15	0.25	0.20	15	0.30	0.30
	10	0.08	0.08	10	0.10	0.10	10	0.15	0.10	10	0.20	0.20	10	0.25	0.20	10	0.30	0.30
	15	0.08	0.08	15	0.10	0.10	15	0.15	0.10	15	0.20	0.20	15	0.25	0.20	15	0.30	0.30
	10	0.08	0.08	10	0.10	0.10	10	0.15	0.10	10	0.20	0.20	10	0.25	0.20	10	0.30	0.30
	30	0.10	0.10	30	0.20	0.10	30	0.30	0.20	30	0.30	0.20	30	0.40	0.30	30	0.50	0.30
	25	0.10	0.10	25	0.20	0.10	25	0.30	0.20	25	0.30	0.20	25	0.40	0.30	25	0.50	0.30
	20	0.10	0.10	20	0.20	0.10	20	0.30	0.20	20	0.30	0.20	20	0.40	0.30	20	0.50	0.30
	20	0.10	0.10	20	0.20	0.10	20	0.30	0.20	20	0.30	0.20	20	0.40	0.30	20	0.50	0.30
	25	0.10	0.10	25	0.20	0.10	25	0.30	0.20	25	0.30	0.20	25	0.40	0.30	25	0.50	0.30
	20	0.10	0.10	20	0.20	0.10	20	0.30	0.20	20	0.30	0.20	20	0.40	0.30	20	0.50	0.30
	10	0.06	0.05	10	0.10	0.10	10	0.12	0.10	10	0.18	0.15	10	0.20	0.20	10	0.25	0.20
	10	0.06	0.05	10	0.10	0.10	10	0.12	0.10	10	0.18	0.15	10	0.20	0.20	10	0.25	0.20
	10	0.06	0.05	10	0.10	0.10	10	0.12	0.10	10	0.18	0.15	10	0.20	0.20	10	0.25	0.20
	10	0.06	0.05	10	0.10	0.10	10	0.12	0.10	10	0.18	0.15	10	0.20	0.20	10	0.25	0.20
	10	0.06	0.05	10	0.10	0.10	10	0.12	0.10	10	0.18	0.15	10	0.20	0.20	10	0.25	0.20
	10	0.06	0.05	10	0.10	0.10	10	0.12	0.10	10	0.18	0.15	10	0.20	0.20	10	0.25	0.20
	10	0.06	0.05	10	0.10	0.10	10	0.12	0.10	10	0.18	0.15	10	0.20	0.20	10	0.25	0.20
	10	0.06	0.05	10	0.10	0.10	10	0.12	0.10	10	0.18	0.15	10	0.20	0.20	10	0.25	0.20
	8	0.05	0.05	8	0.08	0.05	8	0.10	0.10	8	0.13	0.10	8	0.15	0.15	8	0.20	0.20
	8	0.05	0.05	8	0.08	0.05	8	0.10	0.10	8	0.13	0.10	8	0.15	0.15	8	0.20	0.20
	8	0.05	0.05	8	0.08	0.05	8	0.10	0.10	8	0.13	0.10	8	0.15	0.15	8	0.20	0.20

The specified cutting data are guide values.

The optimum data for the respective machining task should be determined during the test or machining.

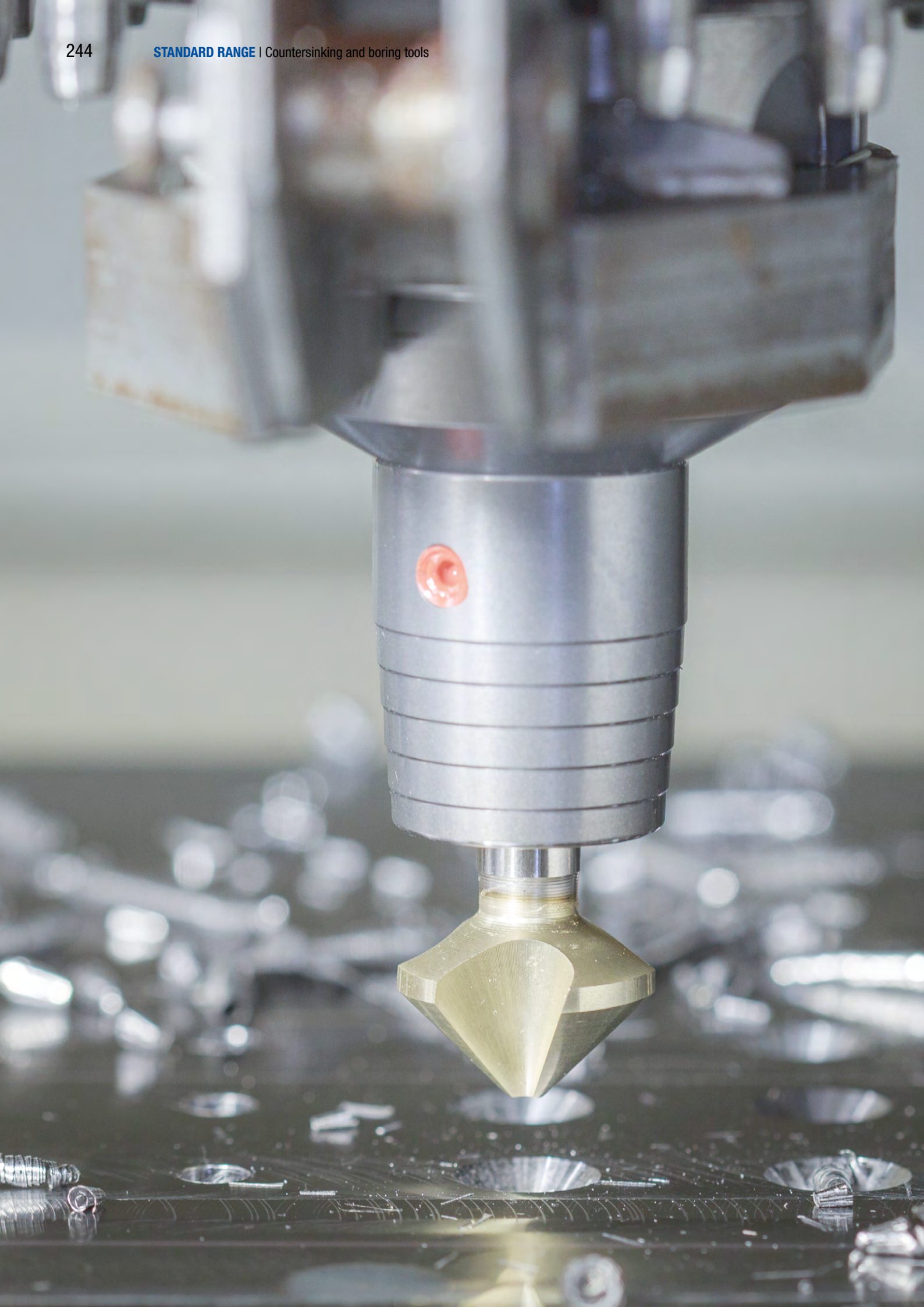

COUNTERSINKING AND BORING TOOLS

Introduction

Product overview	246
Countersink	248
Counterbores	267
Boring tools	278

Technical appendix

Cutting data recommendations	292
------------------------------------	-----

PRODUCT OVERVIEW

Countersinking and boring tools

Countersinking and deburring tools form a comprehensive addition to bore machining. Countersinking operations are performed on practically all parts that have to be machined. Countersinking tools are required in particular for flush screw joints. The spectrum extends from simple deburring tools right up to high-tech countersinking tools with extremely unequal cutting edge spacing and highly wear-resistant coating.

Diameters up to 100 mm are available ex stock depending on the type of tool. Designs made of HSS, solid carbide and various coatings provide the right tool for every application. The coatings also make a significant contribution to improving the tool life and performance. Ground chip spaces ensure reliable chip removal and good support in the bore is ensured by the radial undercut.



Countersink



Countersink

EUC-Speed countersinks 90° with extremely unequal cutting edge spacing.
Precision design made of HSS and solid carbide with special coating.
Countersink 90°/60° in accordance with DIN and factory standard with even cutting edge spacing.
Precision design made of HSS and solid carbide with various coatings.

∅ area: 4.300 - 80.000* mm



Counterbores

With solid and replaceable pilots.
Designs made of HSS and HSS with TiN coating.

∅ area: 6.000 - 63.000* mm



Boring tools



Boring tools

HSS boring tools are used to create the necessary initial size of a bore for the subsequent reaming. They are characterised by their simple handling. More important, however, is the matching of the diameter to the reaming operation. This eliminates the need for expensive drilling tools with intermediate diameters. Longer tool lives are achieved due to the chip space ground design.

Ø area: 4.800 - 100.000* mm

EUC-Speed I B044210

Precision design, extremely unequal spacing

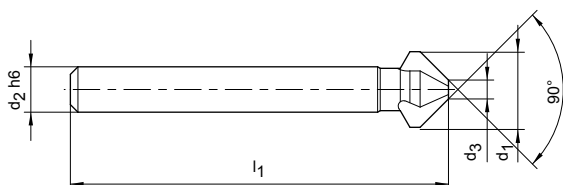

Design:

Diameter:

6.300 - 31.000 mm

Cutting direction:

Right-hand cutting

Cutting material:

Solid carbide, special coating (HP437)

Special feature:

Radially relieved.

Shank tolerance h6 (suitable for hydraulic chucks and shrink chucks).



Preferred series available from stock

Dimensions				z	Order no.
d ₁	d ₂ h6	d ₃	l ₁		
6,300	5	1,5	45	3	30729770
8,300	6	2,0	50	3	30729772
10,400	6	2,5	50	3	30729774
12,400	8	2,8	56	3	30729776
16,500	10	3,2	60	3	30729778
20,500	10	3,5	63	3	30729780
25,000	10	3,8	67	3	30729782
31,000	12	4,2	71	3	30729783

Dimensions in mm.

For cutting data recommendations, see end of chapter.

EUC-Speed I B054210

Precision design, extremely unequal spacing

Design:

Diameter:

Cutting direction:

Cutting material:

4.300 - 31.000 mm

Right-hand cutting

HSS, special coating (SP345)

Special feature:

Radially relieved.

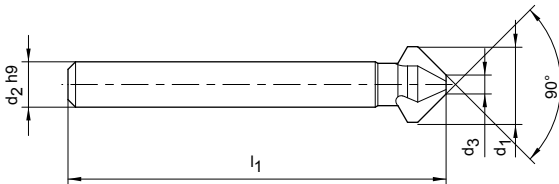

Preferred series available from stock

Dimensions				z	Order no.
d ₁	d ₂ h9	d ₃	l ₁		
4,300	4	1,3	40	3	30662977
6,000	5	1,5	45	3	30662978
6,300	5	1,5	45	3	30602669
8,000	6	2,0	50	3	30662979
8,300	6	2,0	50	3	30662980
10,000	6	2,5	50	3	30662982
10,400	6	2,5	50	3	30602672
11,500	8	2,8	56	3	30662984
12,400	8	2,8	56	3	30662985
15,000	10	3,2	60	3	30662986
16,500	10	3,2	60	3	30602673
19,000	10	3,5	63	3	30662987
20,500	10	3,5	63	3	30602674
23,000	10	3,8	67	3	30662988
25,000	10	3,8	67	3	30602675
31,000	12	4,2	71	3	30662989

Countersink set, EUC-Speed 054218, HSS design

Set	Diameter	EUC-Speed, HSS 054218 Order no.
5-piece	6.30 / 10.40 / 16.50 / 20.50 / 25.00	30602967



Dimensions in mm.

For cutting data recommendations, see end of chapter.

EUC-Speed | B054207 | B054209

Precision design, extremely unequal spacing

Design:

Diameter:
Cutting direction:
Cutting material:

4.300 - 31.000 mm
Right-hand cutting
HSS, special coating
(SP345)

Special feature:

Radially relieved.

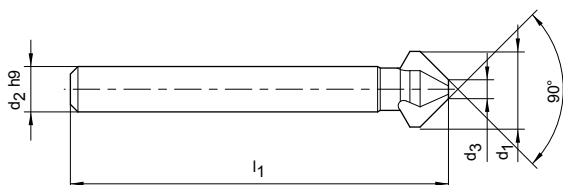

Preferred series available from stock | Shank with three clamping surfaces, B054207

Dimensions					90° design with surface
d_1	d_2 h9	d_3	l_1	z	Order no.
4,300	4	1,3	40	3	30881866
6,000	5	1,5	45	3	30881867
6,300	5	1,5	45	3	30881868
8,000	6	2,0	50	3	30881869
8,300	6	2,0	50	3	30881870
10,000	6	2,5	50	3	30881871
10,400	6	2,5	50	3	30881872
11,500	8	2,8	56	3	30881873
12,400	8	2,8	56	3	30881874
15,000	10	3,2	60	3	30881875
16,500	10	3,2	60	3	30881876
19,000	10	3,5	63	3	30881877
20,500	10	3,5	63	3	30881878
23,000	10	3,8	67	3	30881879
25,000	10	3,8	67	3	30881880
31,000	12	4,2	71	3	30881881

Preferred series available from stock | Long design, B054209

6.300	5	1.5	104	3	31006152
8.300	6	2.0	105	3	31006153
10.400	6	2.5	107	3	31006154
12.400	8	2.8	108	3	31006155
16.500	10	3.2	111	3	31006156
20.500	10	3.5	114	3	31006157
25.000	10	3.8	118	3	31006158
31.000	12	4.2	140	3	31006159

Countersink sets, EUC-Speed | B054217

Set	Diameter	HSS, 3 clamping surfaces B054217
		Order no.
5-piece	6.30 / 10.40 / 16.50 / 20.50 / 25.00	30897967



Dimensions in mm.

For cutting data recommendations, see end of chapter.

EUC-Speed 60° | B054110 | B054107

Precision design, extremely unequal spacing

Design:

Diameter:

6.300 - 25.000 mm

Cutting direction:

Right-hand cutting

Cutting material:

HSS, special coating (SP345)

Special feature:

Radially relieved.

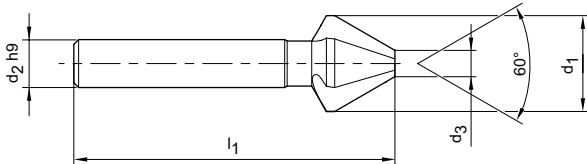

Preferred series available from stock

Dimensions					60° design	60° design with surface
d ₁	d ₂ h9	d ₃	l ₁	z	Order no.	Order no.
6,300	5	1,6	45	3	31051748	31051765
8,000	6	2,0	50	3	31051749	31051766
10,000	6	2,5	50	3	31051760	31051767
12,500	8	3,2	56	3	31051761	31051768
16,000	10	4,0	63	3	31051762	31051769
20,000	10	5,0	67	3	31051763	31051770
25,000	10	6,3	71	3	31051764	31051771

Dimensions in mm.

For cutting data recommendations, see end of chapter.

90° countersink I B041020

Precision design

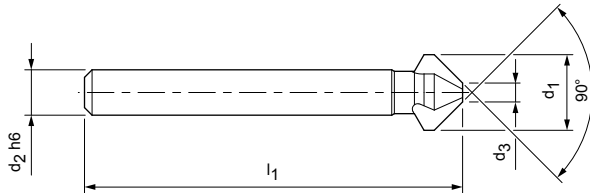

Design:

Diameter:

Cutting direction:

Cutting material:

6.300 - 31.000 mm

Right-hand cutting

Solid carbide, uncoated
(HU318)

Special feature:

Radially relieved.

Shank tolerance h6 (suitable for hydraulic chucks
and shrink chucks).



Preferred series available from stock

Dimensions				z	Order no.
d ₁	d ₂ h6	d ₃	l ₁		
6,300	5	1,5	45	3	30110278
8,300	6	2	50	3	30110280
10,400	6	2,5	50	3	30110282
12,400	8	2,8	56	3	30110284
16,500	10	3,2	60	3	30110286
20,500	10	3,5	63	3	30110288
25,000	10	3,8	67	3	30110290
31,000	12	4,2	71	3	30110292

Dimensions in mm.

For cutting data recommendations, see end of chapter.

90° countersink | B051210

Precision design

Design:

Diameter:

4.300 - 31.000 mm

Cutting direction:

Right-hand cutting

Cutting material:

HSS, uncoated
(SU343)

Special feature:

Radially relieved.

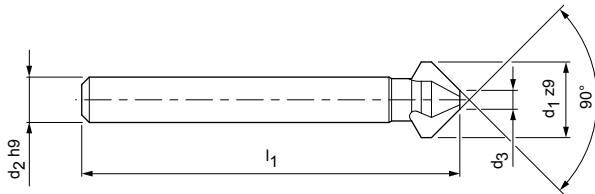

Preferred series available from stock

Dimensions				z	Order no.
d ₁ z ₉	d ₂ h ₉	d ₃	l ₁		
4,300	4	1,3	40	3	30111110
4,800	4	1,5	40	3	30111112
5,000	4	1,5	40	3	30111114
5,300	4	1,5	40	3	30111116
5,800	5	1,5	45	3	30111118
6,000	5	1,5	45	3	30111120
6,300	5	1,5	45	3	30111122
7,000	6	1,8	50	3	30111124
7,300	6	1,8	50	3	30111126
8,000	6	2	50	3	30111128
8,300	6	2	50	3	30111130
9,400	6	2,2	50	3	30111132
10,000	6	2,5	50	3	30111134
10,400	6	2,5	50	3	30111136
11,500	8	2,8	56	3	30111138
12,400	8	2,8	56	3	30111140
13,400	8	2,9	56	3	30111142
14,400	8	3	56	3	30111144
15,000	10	3,2	60	3	30111146
16,500	10	3,2	60	3	30111148
19,000	10	3,5	63	3	30111150
20,500	10	3,5	63	3	30111152
23,000	10	3,8	67	3	30111154
25,000	10	3,8	67	3	30111156
26,000	10	3,8	67	3	30111158
28,000	12	4	71	3	30111160
30,000	12	4,2	71	3	30111162
31,000	12	4,2	71	3	30111164

Countersink set, 90°, 051218, precision design, uncoated

Set	Diameter	Order no.
5-piece	6.30/10.40/16.50/20.50/25.00	30111176



Dimensions in mm.

For cutting data recommendations, see end of chapter.

90° countersink | B053212

Precision design

Design:

Diameter:

Cutting direction:

Cutting material:

6.300 - 31.000 mm

Right-hand cutting

HSS, TiAlN-coated
(SP348)

Special feature:

Radially relieved.

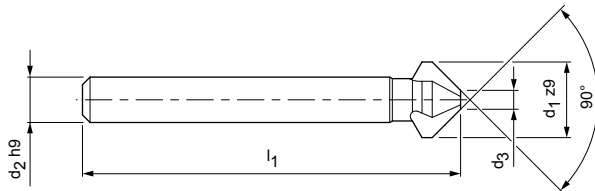

Preferred series available from stock

Dimensions				z	Order no.
d ₁ z ₉	d ₂ h ₉	d ₃	l ₁		
6,300	5	1,5	45	3	30117700
8,300	6	2	50	3	30117702
10,400	6	2,5	50	3	30117704
12,400	8	2,8	56	3	30117706
15,000	10	3,2	60	3	30117709
16,500	10	3,2	60	3	30117711
20,500	10	3,5	63	3	30117713
25,000	10	3,8	67	3	30117715
31,000	12	4,2	71	3	30117717

Dimensions in mm.

For cutting data recommendations, see end of chapter.

90° countersink | B053210

Precision design

Design:

Diameter:

4.800 - 31.000 mm

Cutting direction:

Right-hand cutting

Cutting material:

HSS, TiN-coated
(SP347)

Special feature:

Radially relieved.

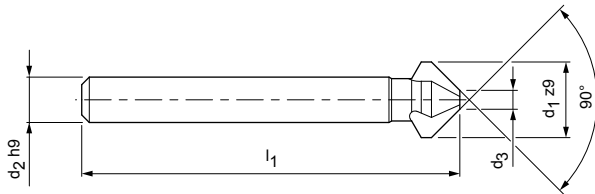

Preferred series available from stock

Dimensions				z	Order no.
d ₁ z ₉	d ₂ h ₉	d ₃	l ₁		
4,800	4	1,5	40	3	30117658
5,000	4	1,5	40	3	30117660
6,000	5	1,5	45	3	30117662
6,300	5	1,5	45	3	30117664
7,000	6	1,8	50	3	30117666
7,300	6	1,8	50	3	30117668
8,000	6	2	50	3	30117670
8,300	6	2	50	3	30117672
9,400	6	2,2	50	3	30117674
10,000	6	2,5	50	3	30117676
10,400	6	2,5	50	3	30117678
11,500	8	2,8	56	3	30117680
12,400	8	2,8	56	3	30117682
15,000	10	3,2	60	3	30117684
16,500	10	3,2	60	3	30117686
19,000	10	3,5	63	3	30117688
20,500	10	3,5	63	3	30117690
23,000	10	3,8	67	3	30117692
25,000	10	3,8	67	3	30117694
31,000	12	4,2	71	3	30117696

Countersink set, 90°, 053220, precision design, TiN-coated

Set	Diameter	Order no.
5-piece	6.30/10.40/16.50/20.50/25.00	30359531



Dimensions in mm.

For cutting data recommendations, see end of chapter.

90° countersink | B051207

Precision design, shank with 3 clamping surfaces

Design:

Diameter:
Cutting direction:
Cutting material:

4.300 - 31.000 mm
Right-hand cutting
HSS, uncoated
(SU343)

Special feature:

Radially relieved.

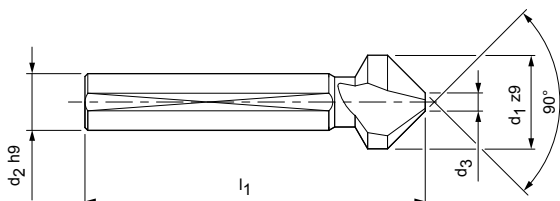

Preferred series available from stock

Dimensions				z	Order no.
d ₁ z ₉	d ₂ h ₉	d ₃	l ₁		
4,300	4	1,3	40	3	31304665
6,000	5	1,5	45	3	31304666
6,300	5	1,5	45	3	31304667
8,000	6	2	50	3	31304668
8,300	6	2	50	3	31304669
10,000	6	2,5	50	3	31304670
10,400	6	2,5	50	3	31304671
11,500	8	2,8	56	3	30111000
12,400	8	2,8	56	3	30111002
13,400	8	2,9	56	3	30111004
15,000	10	3,2	60	3	30111006
16,500	10	3,2	60	3	30111008
19,000	10	3,5	63	3	30111010
20,500	10	3,5	63	3	30111012
23,000	10	3,8	67	3	30111014
25,000	10	3,8	67	3	30111016
26,000	10	3,8	67	3	30111018
28,000	12	4	71	3	30111020
30,000	12	4,2	71	3	30111022
31,000	12	4,2	71	3	30111024

Dimensions in mm.

For cutting data recommendations, see end of chapter.

90° countersink | B053207

Precision design, shank with 3 clamping surfaces

Design:

Diameter:

4.300 - 31.000 mm

Cutting direction:

Right-hand cutting

Cutting material:

HSS, TiN-coated
(SP347)

Special feature:

Radially relieved.

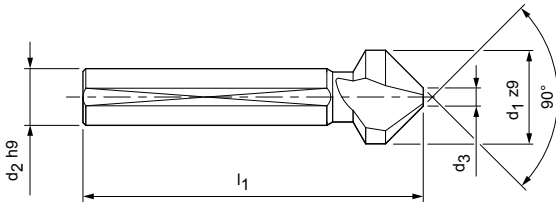

Preferred series available from stock

Dimensions				z	Order no.
d ₁ z ₉	d ₂ h ₉	d ₃	l ₁		
4,300	4	1,3	40	3	31304672
6,000	5	1,5	45	3	31304673
6,300	5	1,5	45	3	31304674
8,000	6	2	50	3	31304675
8,300	6	2	50	3	31304676
10,000	6	2,5	50	3	31304677
10,400	6	2,5	50	3	31304678
11,500	8	2,8	56	3	30117648
12,400	8	2,8	56	3	30117649
13,400	8	2,9	56	3	30117650
15,000	10	3,2	60	3	30117651
16,500	10	3,2	60	3	30117652
19,000	10	3,5	63	3	30117653
20,500	10	3,5	63	3	30117654
23,000	10	3,8	67	3	30117655
25,000	10	3,8	67	3	30117656
31,000	12	4,2	71	3	30136388

Dimensions in mm.

For cutting data recommendations, see end of chapter.

90° countersink | B051310

Precision design, morse taper shank

Design:

Diameter:
Cutting direction:
Cutting material:

15.000 - 100.000 mm
Right-hand cutting
HSS, uncoated
(SU343)

Special feature:

Radially relieved.

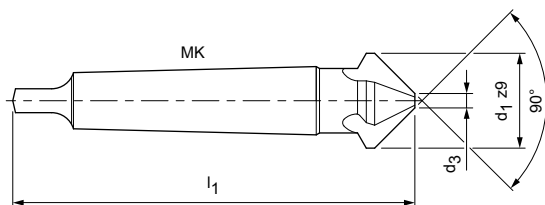

Preferred series available from stock

Dimensions				z	Order no.
d ₁ z ₉	d ₃	l ₁	MK		
15,000	3,2	85	1	3	30111220
16,500	3,2	85	1	3	30111222
19,000	3,5	100	2	3	30111224
20,500	3,5	100	2	3	30111226
23,000	3,8	106	2	3	30111228
25,000	3,8	106	2	3	30111230
26,000	3,8	106	2	3	30111232
28,000	4	112	2	3	30111234
30,000	4,2	112	2	3	30111236
31,000	4,2	112	2	3	30111238
34,000	4,5	118	2	3	30111240
37,000	4,8	118	2	3	30111242
40,000	10	140	3	3	30111244
50,000	14	150	3	3	30111246
63,000	16	180	4	3	30111248
80,000	22	190	4	3	30111250
100,000	28	200	4	3	30111252

Dimensions in mm.

For cutting data recommendations, see end of chapter.

90° countersink | B053310

Precision design, morse taper shank

Design:

Diameter:

25.000 - 63.000 mm

Cutting direction:

Right-hand cutting

Cutting material:

HSS, TiN-coated
(SP347)

Special feature:

Radially relieved.

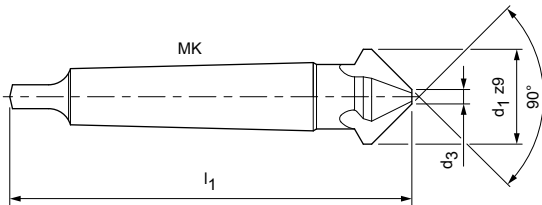

Preferred series available from stock

Dimensions				z	Order no.
d ₁ z ₉	d ₃	l ₁	MK		
25,000	3,8	106	2	3	30117720
31,000	4,2	112	2	3	30117722
37,000	4,8	118	2	3	30117724
40,000	10	140	3	3	30117726
50,000	14	150	3	3	30117728
63,000	16	180	4	3	30117730

Dimensions in mm.

For cutting data recommendations, see end of chapter.

90° countersink | B050810

Multi-fluted countersink for machining high-strength materials

Design:

Diameter:

Cutting direction:

Cutting material:

8.000 - 20.000 mm

Right-hand cutting

HSS, uncoated

(SU343)

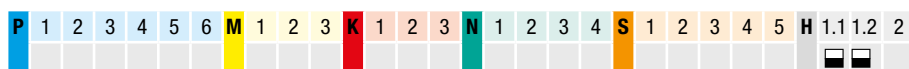
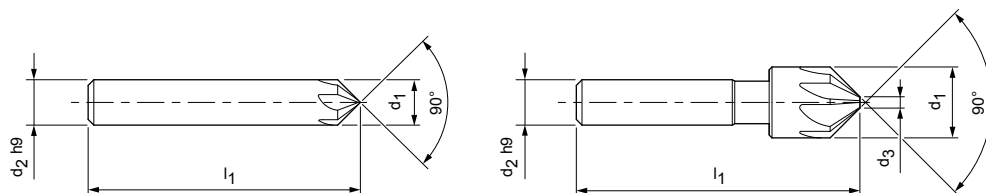
Preferred series available from stock

Dimensions				z	Order no.
d ₁	d ₂ h9	d ₃	l ₁		
8,000	8		48	5	30110910
12,500	8	2	48	5	30110912
16,000	10	3,2	56	7	30110914
20,000	10	5	60	7	30110916

Dimensions in mm.

For cutting data recommendations, see end of chapter.

Countersink WN 181, 90° | B051011

Single-edged design



Design:

Diameter:

Cutting direction:

Cutting material:

6.000 - 31.500 mm

Right-hand cutting

HSS, uncoated
(SU343)

Special feature:

Radially relieved.

Sharp point.

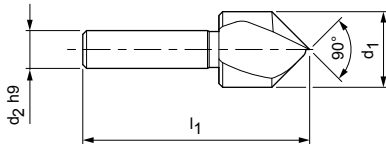

Preferred series available from stock

Dimensions				Order no.
d_1	d_2 h9	l_1		
6,000*	6	45		30110944
8,000	8	50		30110946
10,000	8	49		30110948
12,500	8	49		30110950
16,000	10	56		30110952
20,000	10	60		30110954
25,000	12	75		30110956
31,500	12	80		30110958

* Cuts on both sides

Dimensions in mm.

For cutting data recommendations, see end of chapter.

60° countersink | B051110

Precision design

Design:

Diameter:

Cutting direction:

Cutting material:

6.300 - 25.000 mm

Right-hand cutting

HSS, uncoated

(SU343)

Special feature:

Radially relieved.

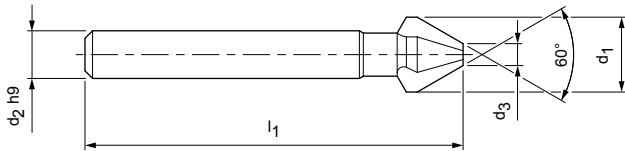

Preferred series available from stock

Dimensions				z	Order no.
d ₁	d ₂ h9	d ₃	l ₁		
6,300	5	1,6	45	3	30110968
8,000	6	2	50	3	30110970
10,000	6	2,5	50	3	30110972
12,500	8	3,2	56	3	30110974
16,000	10	4	63	3	30110976
20,000	10	5	67	3	30110978
22,500	10	5,6	71	3	30110980
25,000	10	6,3	71	3	30110982

Dimensions in mm.

For cutting data recommendations, see end of chapter.

60° countersink | B053320

Precision design

Design:

Diameter:

Cutting direction:

Cutting material:

6.300 - 25.000 mm

Right-hand cutting

HSS, TiN-coated
(SP347)

Special feature:

Radially relieved.

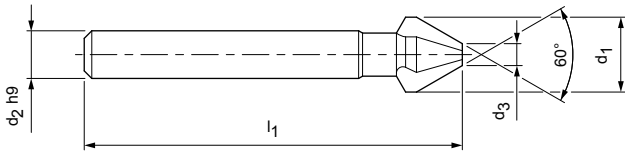

Preferred series available from stock

Dimensions				z	Order no.
d ₁	d ₂ h9	d ₃	l ₁		
6,300	5	1,6	45	3	30117732
8,000	6	2	50	3	30117734
10,000	6	2,5	50	3	30117736
12,500	8	3,2	56	3	30117738
16,000	10	4	63	3	30117740
20,000	10	5	67	3	30117742
22,500	10	5,6	71	3	30117744
25,000	10	6,3	71	3	30117746

Dimensions in mm.

For cutting data recommendations, see end of chapter.

60° countersink | B051111

Precision design with morse taper shank

Design:

Diameter:

Cutting direction:

Cutting material:

16.000 - 80.000 mm

Right-hand cutting

HSS, uncoated
(SU343)

Special feature:

Radially relieved.

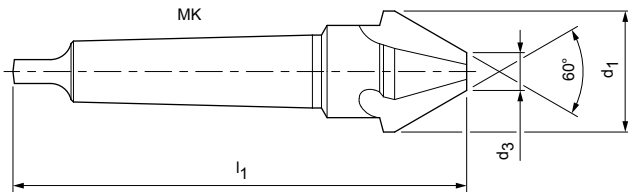
Preferred series available from stock

Dimensions				z	Order no.
d ₁	d ₃	l ₁	MK		
16,000	4	90	1	3	30110984
20,000	5	106	2	3	30110986
25,000	6,3	112	2	3	30110988
31,500	10	118	2	3	30110990
40,000	12,5	150	3	3	30110992
50,000	16	160	3	3	30110994
63,000	20	190	4	3	30110996
80,000	25	200	4	3	30110998

Dimensions in mm.

For cutting data recommendations, see end of chapter.

60° countersink I B050610

Multi-fluted countersink für machining high-strength materials

Design:

Diameter:

Cutting direction:

Cutting material:

8.000 - 20.000 mm

Right-hand cutting

HSS, uncoated

(SU343)

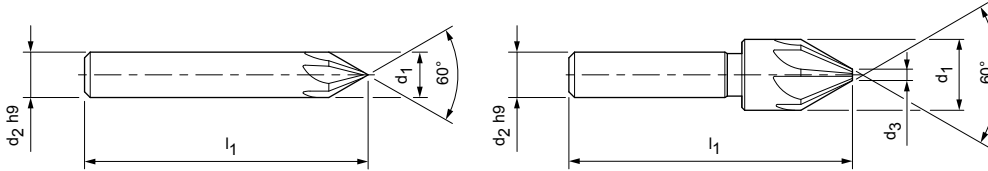

Preferred series available from stock

Dimensions				z	Order no.
d_1	d_2 h9	d_3	l_1		
8,000	8		50	5	30110881
12,500	8	2	50	5	30110883
16,000	10	3,2	60	7	30110885
20,000	10	5	63	7	30110887

Dimensions in mm.

For cutting data recommendations, see end of chapter.

Countersink WN 180, 60° | B051010

Single-edged design



Design:

Diameter:

Cutting direction:

Cutting material:

6.000 - 31.500 mm

Right-hand cutting

HSS, uncoated

(SU343)

Special feature:

Radially relieved.

Sharp point.

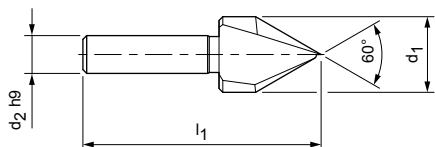

Preferred series available from stock

Dimensions				Order no.
d ₁	d ₂ h9	l ₁		
6,000	6	45		30135229
8,000	8	50		30110930
10,000	8	52		30110932
12,500	8	52		30110934
16,000	10	60		30110936
20,000	10	63		30110938
25,000	12	82		30110940
31,500	12	90		30110942

Dimensions in mm.

For cutting data recommendations, see end of chapter.

Counterbore | B051510

For fine through bore

Design:

Diameter:

6.000 - 20.000 mm

Cutting direction:

Right-hand cutting

Cutting material:

HSS, uncoated
(SU343)

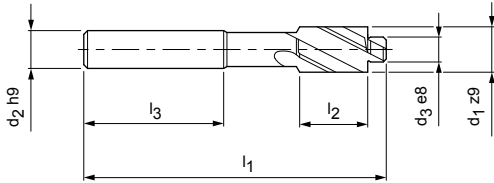

Preferred series available from stock

Dimensions							z	Order no.
d ₁ z9	d ₂ h9	d ₃ e8	Thread of	l ₁	l ₂	l ₃		
6,000	5	3,2	M3	71	14	31,5	3	30165316
6,500	5	3,2	M3	71	14	31,5	3	30111323
6,500	5	3,7	M3,5	71	14	31,5	3	30111325
8,000	5	4,3	M4	71	14	31,5	3	30111327
10,000	8	5,3	M5	80	18	35,5	3	30111329
11,000	8	6,4	M6	80	18	35,5	3	30111331
15,000	12,5	8,4	M8	100	22	40	3	30111333
18,000	12,5	10,5	M10	100	22	40	3	30111335
20,000	12,5	13	M12	100	22	40	3	30111337



Counterbore set for fine through bore 051513, in metal case, uncoated

Set	Thread of	Order no.
6-piece	M3, M4, M5, M6, M8, M10	30111371

Dimensions in mm.

For cutting data recommendations, see end of chapter.

Counterbore | B053510

For fine through bore

Design:

Diameter:

Cutting direction:

Cutting material:

6.000 - 20.000 mm

Right-hand cutting

HSS, TiN-coated

(SP347)

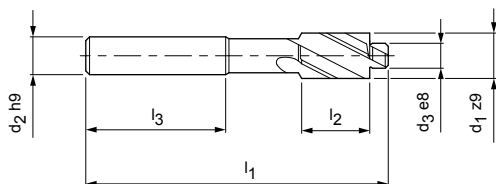

Preferred series available from stock

Dimensions							z	Order no.
d ₁ z9	d ₂ h9	d ₃ e8	Thread of	l ₁	l ₂	l ₃		
6,000	5	3,2	M3	71	14	31,5	3	30117754
6,500	5	3,2	M3	71	14	31,5	3	30117755
8,000	5	4,3	M4	71	14	31,5	3	30117756
10,000	8	5,3	M5	80	18	35,5	3	30117757
11,000	8	6,4	M6	80	18	35,5	3	30117758
15,000	12,5	8,4	M8	100	22	40	3	30117759
18,000	12,5	10,5	M10	100	22	40	3	30117760
20,000	12,5	13	M12	100	22	40	3	30117761

Dimensions in mm.

For cutting data recommendations, see end of chapter.

Counterbore | B051511

For medium through bore

Design:

Diameter:

6.00 - 20.000 mm

Cutting direction:

Right-hand cutting

Cutting material:

HSS, uncoated
(SU343)

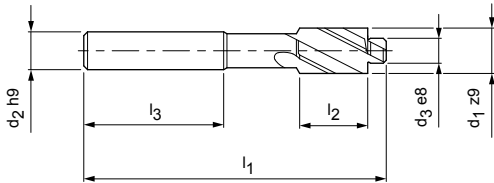

Preferred series available from stock

Dimensions							z	Order no.
d ₁ z ₉	d ₂ h ₉	d ₃ e ₈	Thread of	l ₁	l ₂	l ₃		
6,000	5	3,4	M3	71	14	31,5	3	30165317
6,500	5	3,4	M3	71	14	31,5	3	30111339
6,500	5	3,9	M3,5	71	14	31,5	3	30111341
8,000	5	4,5	M4	71	14	31,5	3	30111343
10,000	8	5,5	M5	80	18	35,5	3	30111345
11,000	8	6,6	M6	80	18	35,5	3	30111347
15,000	12,5	9	M8	100	22	40	3	30111349
18,000	12,5	11	M10	100	22	40	3	30111351
20,000	12,5	13,5	M12	100	22	40	3	30111353



Counterbore set for through bore, medium drilling

051514, in metal case, uncoated

Set	Thread of	Order no.
6-piece	M3, M4, M5, M6, M8, M10	30111372

Dimensions in mm.

For cutting data recommendations, see end of chapter.

Counterbore | B053511

For medium through bore

Design:

Diameter:

Cutting direction:

Cutting material:

6.000 - 20.000 mm

Right-hand cutting

HSS, TiN-coated

(SP347)

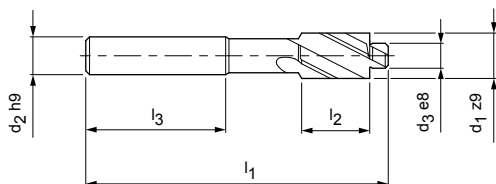

Preferred series available from stock

Dimensions							z	Order no.
d ₁ z9	d ₂ h9	d ₃ e8	Thread of	l ₁	l ₂	l ₃		
6,000	5	3,4	M3	71	14	31,5	3	30117762
6,500	5	3,4	M3	71	14	31,5	3	30117763
8,000	5	4,5	M4	71	14	31,5	3	30117764
10,000	8	5,5	M5	80	18	35,5	3	30117765
11,000	8	6,6	M6	80	18	35,5	3	30117766
15,000	12,5	9	M8	100	22	40	3	30117767
18,000	12,5	11	M10	100	22	40	3	30117768
20,000	12,5	13,5	M12	100	22	40	3	30117769

Dimensions in mm.

For cutting data recommendations, see end of chapter.

Counterbore | B051512

For tapping bore

Design:

Diameter:

Cutting direction:

Cutting material:

6.000 - 20.000 mm

Right-hand cutting

HSS, uncoated

(SU343)

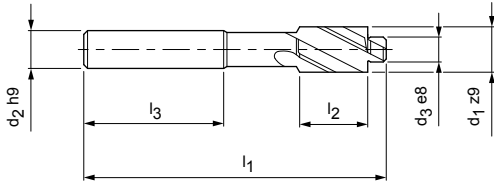

Preferred series available from stock

Dimensions							z	Order no.
d ₁ z9	d ₂ h9	d ₃ e8	Thread of	l ₁	l ₂	l ₃		
6,000	5	2,5	M3	71	14	31,5	3	30165315
6,500	5	2,5	M3	71	14	31,5	3	30111355
6,500	5	2,9	M3,5	71	14	31,5	3	30111357
8,000	5	3,3	M4	71	14	31,5	3	30111359
10,000	8	4,2	M5	80	18	35,5	3	30111361
11,000	8	5	M6	80	18	35,5	3	30111363
15,000	12,5	6,8	M8	100	22	40	3	30111365
18,000	12,5	8,5	M10	100	22	40	3	30111367
20,000	12,5	10,2	M12	100	22	40	3	30111369



Counterbore set for tapping bore 051515, in metal case, uncoated

Set	Thread of	Order no.
6-piece	M3, M4, M5, M6, M8, M10	30359523

Dimensions in mm.

For cutting data recommendations, see end of chapter.

Counterbore WN 178 | B051710

With morse taper shank, for fine through bore

Design:

Diameter:

Cutting direction:

Cutting material:

18.000 - 40.000 mm

Right-hand cutting

HSS, uncoated
(SU343)

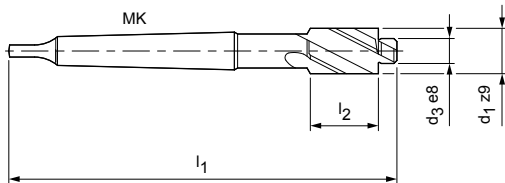

Preferred series available from stock

Dimensions						z	Order no.
d ₁ z ₉	d ₃ e ₈	Thread of	l ₁	l ₂	MK		
18,000	10,5	M10	150	25	2	3	30111529
20,000	13	M12	150	25	2	3	30111531
24,000	15	M14	162	30	2	3	30111533
26,000	17	M16	192	35	3	3	30111535
30,000	19	M18	192	35	3	3	30111537
33,000	21	M20	204	40	3	3	30111539
36,000	23	M22	204	40	3	3	30111541
40,000	25	M24	204	40	3	3	30111543

Dimensions in mm.

For cutting data recommendations, see end of chapter.

Counterbore WN 178 | B051711

With morse taper shank, for medium through bore

Design:

Diameter:

18.000 - 40.000 mm

Cutting direction:

Right-hand cutting

Cutting material:

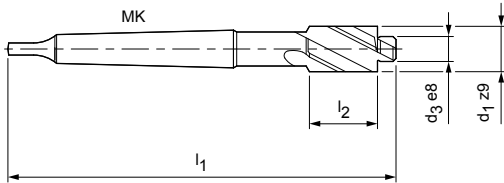
 HSS, uncoated
(SU343)

Preferred series available from stock

Dimensions						z	Order no.
d ₁ z9	d ₃ e8	Thread of	l ₁	l ₂	MK		
18,000	11	M10	150	25	2	3	30111545
20,000	13,5	M12	150	25	2	3	30111547
24,000	15,5	M14	162	30	2	3	30111549
26,000	17,5	M16	192	35	3	3	30111551
30,000	20	M18	192	35	3	3	30111553
33,000	22	M20	204	40	3	3	30111555
36,000	24	M22	204	40	3	3	30111557
40,000	26	M24	204	40	3	3	30111559

Dimensions in mm.

For cutting data recommendations, see end of chapter.

Counterbore | B051610

With morse taper shank, for interchangeable pilots DIN 1868

Design:

Diameter:

Cutting direction:

Cutting material:

15.000 - 63.000 mm

Right-hand cutting

HSS, uncoated

(SU343)

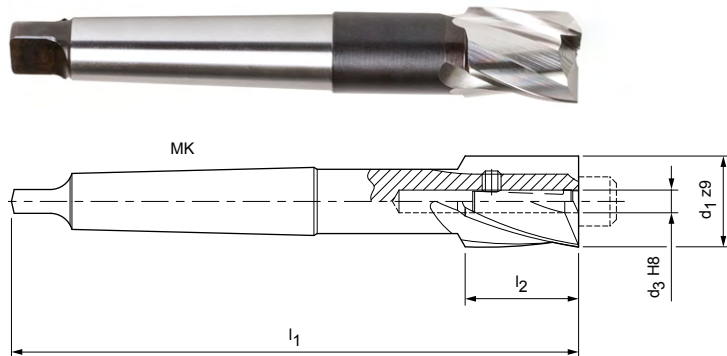
Preferred series available from stock

Dimensions					z	Order no.
d ₁ z9	d ₃ H8	l ₁	l ₂	MK		
15,000	4	132	22	2	3	30111374
18,000	5	140	25	2	3	30111376
20,000	5	140	25	2	3	30111378
24,000	6	150	30	2	3	30111380
26,000	8	180	35	3	3	30111382
30,000	8	180	35	3	3	30111384
33,000	10	190	40	3	3	30111386
36,000	10	190	40	3	3	30111388
40,000	10	190	40	3	3	30111390
43,000	12	236	50	4	4	30111392
46,000	12	236	50	4	4	30111394
50,000	12	236	50	4	4	30111397
54,000	16	250	63	4	4	30111399
58,000	16	250	63	4	4	30111401
61,000	16	250	63	4	4	30111403
63,000	16	250	63	4	4	30111405

Dimensions in mm.

For cutting data recommendations, see end of chapter.

Pilots I B051611

For counterbore DIN 375, for fine through bore

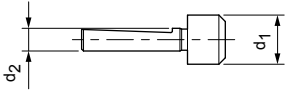

Preferred series available from stock

Dimensions			Countersink \emptyset	Order no.
d_1	d_2 f7	Thread of		
8,400	4	M 8	15	30111409
8,400	5	M 8	18 / 20	30111424
10,500	5	M 10	18 / 20	30111414
10,500	6	M 10	24	30111432
13,000	5	M 12	20	30111418
13,000	6	M 12	24	30111438
13,000	8	M 12	26	30111452
15,000	6	M 14	24	30111442
15,000	8	M 14	26 / 30	30111458
17,000	8	M 16	26 / 30	30111462
17,000	10	M 16	33	30111474
19,000	8	M 18	30	30111466
19,000	10	M 18	33 / 36	30111478
21,000	10	M 20	33 / 36 / 40	30111484
23,000	10	M 22	36 / 40	30111488
23,000	12	M 22	43	30111500
25,000	10	M 24	40	30111492
25,000	12	M 24	43 / 46	30111504

Pilots I B051611

For counterbore DIN 375, for medium through bore

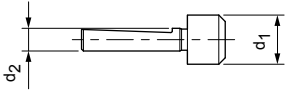

DIN
1868

Preferred series available from stock

Dimensions			Countersink \emptyset	Order no.
d_1	d_2 f7	Thread of		
9,000	4	M 8	15	30111411
9,000	5	M 8	18 / 20	30111428
11,000	5	M 10	18 / 20	30111416
11,000	6	M 10	24	30111434
13,500	5	M 12	20	30111420
13,500	6	M 12	24	30111440
13,500	8	M 12	26	30111454
15,500	6	M 14	24	30111444
15,500	8	M 14	26 / 30	30111460
17,500	8	M 16	26 / 30	30111464
17,500	10	M 16	33	30111476
20,000	8	M 18	30	30111468
20,000	10	M 18	33 / 36	30111482
22,000	10	M 20	33 / 36 / 40	30111486
24,000	10	M 22	36 / 40	30111490
24,000	12	M 22	43	30111502
26,000	10	M 24	40	30111494
26,000	12	M 24	43 / 46	30111505
30,000	12	M 27	43 / 46	30111509
30,000	16	M 27	54	30111519
33,000	12	M 30	50	30111511
33,000	16	M 30	54 / 61	30111523
36,000	16	M 33	54 / 58 / 63	30111525
39,000	16	M 36	58 / 61	30111527

Pilots I B051611

For counterbore DIN 375, for tapping bore

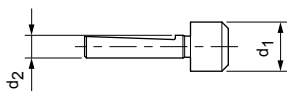

Preferred series available from stock

Dimensions			Countersink \emptyset	Order no.
d_1	d_2 f7	Thread of		
6,800	4	M 8	15	30111407
6,800	5	M 8	18 / 20	30111422
8,500	5	M 10	18 / 20	30111426
8,500	6	M 10	24	30111446
10,200	5	M 12	20	30111412
10,200	6	M 12	24	30111430
10,200	8	M 12	26	30111448
12,000	6	M 14	24	30111436
12,000	8	M 14	26 / 30	30111450
14,000	8	M 16	26 / 30	30111456
14,000	10	M 16	33	30111470
15,500	8	M 18	30	30111460
15,500	10	M 18	33 / 36	30111472
17,500	10	M 20	33 / 36 / 40	30111476
19,500	10	M 22	36 / 40	30111480
19,500	12	M 22	43	30111496
21,000	10	M 24	40	30111484
21,000	12	M 24	43 / 46	30111498
24,000	12	M 27	43 / 46	30111502
24,000	16	M 27	54	30111513
26,500	12	M 30	50	30111507
26,500	16	M 30	54 / 61	30111515
29,500	16	M 33	54 / 58 / 63	30111517
32,000	16	M 36	58 / 61	30111521

Core drill – full size | B050010

Fixed design with cylindrical shank and driving element according to DIN 1809

Design:

Diameter:

Cutting direction:

Cutting material:

Groove direction:

4.700 - 20.200 mm

Right-hand cutting

HSS (SU343)

Approx. 27° right-hand twist

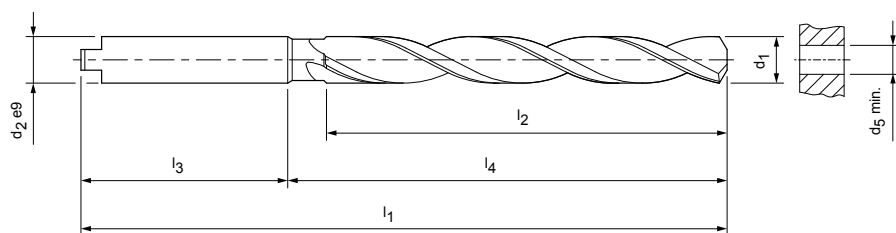

Preferred series available from stock

Dimensions							z	Order no.
d ₁ h8	d ₂ e9	l ₁	l ₂	l ₃	l ₄	d ₅ min.		
5,000	5	108	65	32	76	3,5	3	30110316
6,000	6	116	71	34	82	4,2	3	30110318
7,000	7	133	84	39	94	4,9	3	30110320
8,000	8	142	91	41	101	5,6	3	30110322
9,000	9	151	98	43	108	6,3	3	30110324
10,000	10	162	107	45	117	7,0	3	30110326
11,000	11	173	114	45	128	7,7	3	30110328
12,000	12	184	123	47	137	8,4	3	30110330
13,000	13	184	123	47	137	9,1	3	30110332
14,000	14	194	132	47	147	9,8	3	30110334
15,000	15	202	137	50	152	10,5	3	30110336
16,000	16	211	143	53	158	11,2	3	30110338
17,000	17	218	146	52	166	11,9	3	30110340
18,000	18	226	152	56	170	12,6	3	30110342
19,000	19	234	158	58	176	13,3	3	30110344
20,000	20	242	164	60	182	14,0	3	30110346

Configurable features



Bore diameter tolerance \geq IT8:
 - Diameter in increments of 0.001 mm freely selectable
 - Can be ordered in tolerance \geq IT6



Specification:
 B050010[Diameter][Tolerance]

G variant (see page 303):
 - Diameter in increments of 0.001 mm freely selectable
 - Can be ordered from tolerances \geq 4 μ m

G variant specification:
 B050010[Diameter][Tolerance]

IT8 tolerance example:
 B050010- \emptyset 16.350H8

Bore diameter $d_1 = 16.350$ H8

G variant example:
 B050010- \emptyset 16.350-4

Special tool diameter $d_1 = 16.350 -4$ μ m

Dimensions of configurable series IT8

d_1	d_2 e9	l_1	l_2	l_3	l_4	$d_{5 \text{ min}}$	z
4,700-5,200	5	108	65	32	76	3,5	3
5,201-5,700	5,5	116	71	34	82	4,2	3
5,701-6,200	6	116	71	34	82	4,2	3
6,201-6,700	6,5	124	77	36	93	4,2	3
6,701-7,200	7	133	84	39	94	4,9	3
7,201-7,700	7,5	133	84	39	94	4,9	3
7,701-8,200	8	142	91	41	101	5,6	3
8,201-8,700	8,5	142	91	41	101	5,6	3
8,701-9,200	9	151	98	43	108	6,3	3
9,201-9,700	9,5	151	98	43	108	6,3	3
9,701-10,200	10	162	107	45	117	7,0	3
10,201-10,600	10,5	162	107	45	117	7,0	3
10,601-11,200	11	173	114	45	128	7,7	3
11,201-11,700	11,5	173	114	45	128	7,7	3
11,701-12,200	12	184	123	47	137	8,4	3
12,401-13,200	13	184	123	47	137	9,1	3
13,401-14,200	14	194	132	47	147	9,8	3
14,401-15,200	15	202	137	50	152	10,5	3
15,401-16,200	16	211	143	53	158	11,2	3
16,401-17,200	17	218	146	52	166	11,9	3
17,401-18,200	18	226	152	56	170	12,6	3
18,401-19,200	19	234	158	58	176	13,3	3
19,201-20,200	20	242	164	60	182	14,0	3

Core drill – under size I B050011

Fixed design with cylindrical shank and driving element according to DIN 1809

Design:

Diameter:

Cutting direction:

Cutting material:

Groove direction:

4.800 - 19.700 mm

Right-hand cutting

HSS (SU343)

Approx. 27° right-hand twist

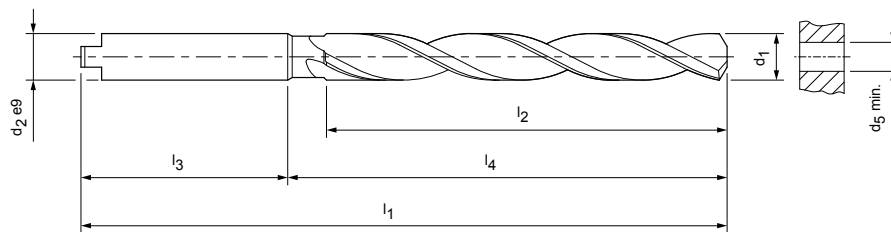
Preferred series available from stock

Dimensions							z	Order no.
d ₁ h8	d ₂ e9	l ₁	l ₂	l ₃	l ₄	d ₅ min.		
4,800	5	108	65	32	76	3,5	3	30110348
5,800	6	116	71	34	82	4,2	3	30110350
6,800	7	133	84	39	94	4,9	3	30110352
7,800	8	142	91	41	101	5,6	3	30110354
8,800	9	151	98	43	108	6,3	3	30110356
9,800	10	162	107	45	117	7,0	3	30110358
10,750	11	173	114	45	128	7,7	3	30110360
11,750	12	184	123	47	137	8,4	3	30110362
12,750	13	184	123	47	137	9,1	3	30110364
13,750	14	194	132	47	147	9,8	3	30110366
14,750	15	202	137	50	152	10,5	3	30110369
15,750	16	211	143	53	158	11,2	3	30110371
16,750	17	218	146	52	166	11,9	3	30110373
17,750	18	226	152	56	170	12,6	3	30110375
18,700	19	234	158	58	176	13,3	3	30110377
19,700	20	242	164	60	182	14,0	3	30110379

Notes

Core drill – full size | B050110

Fixed design with morse taper shank

Design:

Diameter:
Cutting direction:
Cutting material:
Groove direction:

8.000 - 50.000 mm
Right-hand cutting
HSS (SU343)
Approx. 27° right-hand twist

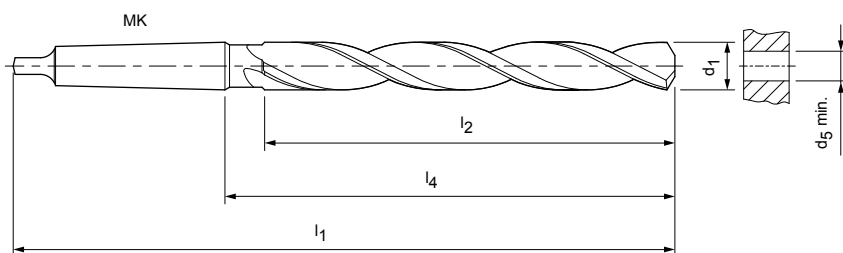

Preferred series available from stock

Dimensions						z	Order no.
d ₁ h8	l ₁	l ₂	l ₄	MK	d ₅ min.		
8,000	156	68	90,5	1	5,6	3	30110381
9,000	162	74	96,5	1	6,3	3	30110383
10,000	168	80	102,5	1	7,0	3	30110385
11,000	175	84	109,5	1	7,7	3	30110387
12,000	182	91	116,5	1	8,4	3	30110389
13,000	182	91	116,5	1	9,1	3	30110391
14,000	189	98	123,5	1	9,8	3	30110393
15,000	212	106	132	2	10,5	3	30110395
16,000	218	108	138	2	11,2	3	30110397
17,000	223	113	143	2	11,9	3	30110399
18,000	228	118	148	2	12,6	3	30110401
19,000	233	123	153	2	13,3	3	30110403
20,000	238	128	158	2	14,0	3	30110405
21,000	243	129	163	2	14,6	3	30110407
22,000	248	134	168	2	15,3	3	30110409
23,000	253	139	173	2	16,0	3	30110411
24,000	281	148	182	3	16,6	3	30110413
25,000	281	144	182	3	17,3	3	30110415
26,000	286	149	187	3	18,0	3	30110417
27,000	291	154	192	3	18,6	3	30110419
28,000	291	162	192	3	19,3	3	30110421
29,000	296	167	197	3	20,0	3	30110423
30,000	296	167	197	3	20,5	3	30110425
31,000	301	170	202	3	21,0	3	30110427
32,000	334	178	210	4	22,0	3	30110429
33,000	334	178	210	4	23,0	3	30110431
34,000	339	183	215	4	24,0	3	30110433
35,000	339	181	215	4	25,0	3	30110435
36,000	344	186	220	4	25,5	3	30110437
37,000	344	186	220	4	26,0	3	30110439
38,000	349	191	225	4	26,5	3	30110441
39,000	349	189	225	4	27,0	3	30110443
40,000	349	189	225	4	28,0	3	30110445
41,000	354	194	230	4	28,5	3	30110447
42,000	354	194	230	4	29,0	3	30110449

Core drill - full size | B050110, fixed design, with morse taper shank

Dimensions						z	Order no.
d ₁ h8	l ₁	l ₂	l ₄	MK	d ₅ min.		
43,000	359	197	235	4	30,0	3	30110451
44,000	359	197	235	4	30,5	3	30110453
45,000	359	197	235	4	31,0	3	30110455
46,000	364	202	240	4	32,0	3	30110457
47,000	364	200	240	4	32,5	3	30110459
48,000	369	205	245	4	33,0	3	30110461
49,000	369	205	245	4	34,0	3	30110463
50,000	369	205	245	4	34,5	3	30110465

Configurable features



Bore diameter tolerance ≥ IT8:
- Diameter in increments of 0.001 mm freely selectable
- Can be ordered in tolerance ≥ IT6



Specification:
B050110[**Diameter**][**Tolerance**]

G variant (see page 303):
- Diameter in increments of 0.001 mm freely selectable
- Can be ordered from tolerances ≥ 4 μm

G variant specification:
B050110[**Diameter**][**Tolerance**]

IT8 tolerance example:
B050110-Ø16.350H8

Bore diameter d₁ = 16.350 H8

G variant example:
B050110-Ø16.350-4

Special tool diameter d₁ = 10.350 -4 μm

Dimensions of configurable series IT8

d ₁	l ₁	l ₂	l ₄	MK	d ₅ min	z
7,600 - 8,700	156	68	90.5	1	5.6	3
8,701 - 9,700	162	74	96.5	1	6.3	3
9,701 - 10,700	168	80	102.5	1	7.0	3
10,701 - 11,700	175	84	109.5	1	7.7	3
11,701 - 12,200	182	91	116.5	1	8.4	3
12,201 - 13,200	182	91	116.5	1	9.1	3
13,201 - 14,200	189	98	123.5	1	9.8	3
14,201 - 15,200	212	106	132	2	10.5	3
15,201 - 16,200	218	108	138	2	11.2	3
16,201 - 17,200	223	113	143	2	11.9	3
17,201 - 18,200	228	118	148	2	12.6	3
18,201 - 19,200	233	123	153	2	13.3	3
19,201 - 20,200	238	128	158	2	14.0	3
20,201 - 21,200	243	129	163	2	14.6	3
21,201 - 22,200	248	134	168	2	15.3	3
22,201 - 23,200	253	139	173	2	16.0	3
23,201 - 24,200	281	148	182	3	16.6	3
24,201 - 25,200	281	144	182	3	17.3	3
25,201 - 26,200	286	149	187	3	18.0	3
26,201 - 27,200	291	154	192	3	18.6	3
27,201 - 28,200	291	162	192	3	19.3	3
28,201 - 29,200	296	167	197	3	20.0	3
29,201 - 30,200	296	167	197	3	20.5	3
30,201 - 31,200	301	170	202	3	21.0	3
31,201 - 32,200	334	178	210	4	22.0	3
32,201 - 33,200	334	178	210	4	23.0	3
33,201 - 34,200	339	183	215	4	24.0	3
34,201 - 35,200	339	181	215	4	25.0	3
35,201 - 36,200	344	186	220	4	25.5	3
36,201 - 37,200	344	186	220	4	26.0	3
37,201 - 38,200	349	191	225	4	26.5	3
38,201 - 39,200	349	189	225	4	27.0	3
39,201 - 40,200	349	189	225	4	28.0	3
40,201 - 41,200	354	194	230	4	28.5	3
41,201 - 42,200	354	194	230	4	29.0	3
42,201 - 43,200	359	197	235	4	30.0	3
43,201 - 44,200	359	197	235	4	30.5	3
44,201 - 45,200	359	197	235	4	31.0	3
45,201 - 46,200	364	202	240	4	32.0	3
46,201 - 47,200	364	200	240	4	32.5	3
47,201 - 48,200	369	205	245	4	33.0	3
48,201 - 49,200	369	205	245	4	34.0	3
49,201 - 50,200	369	205	245	4	34.5	3

Dimensions in mm.

Intermediate diameters that are not covered by the Ø ranges listed can be custom made on request.

Core drill – under size I B050111

Fixed design with morse taper shank

Design:

Diameter:
Cutting direction:
Cutting material:
Groove direction:

7.800 - 49.600 mm
Right-hand cutting
HSS (SU343)
Approx. 27° right-hand twist

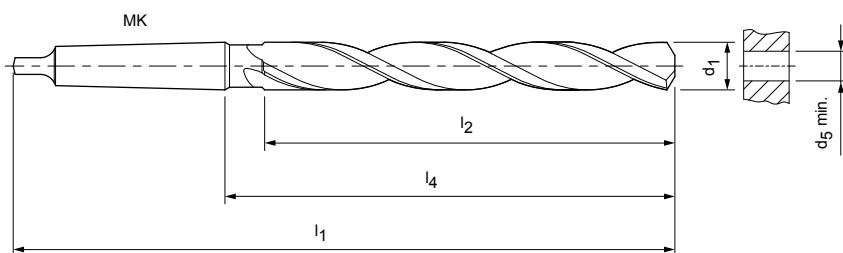

Preferred series available from stock

Dimensions						z	Order no.
d ₁ h8	l ₁	l ₂	l ₄	MK	d ₅ min.		
7,800	156	68	90,5	1	5,6	3	30110467
8,800	162	74	96,5	1	6,3	3	30110469
9,800	168	80	102,5	1	7,0	3	30110471
10,750	175	84	109,5	1	7,7	3	30110473
11,750	182	91	116,5	1	8,4	3	30110475
12,750	182	91	116,5	1	9,1	3	30110477
13,750	189	98	123,5	1	9,8	3	30110479
14,750	212	106	132	2	10,5	3	30110481
15,750	218	108	138	2	11,2	3	30110483
16,750	223	113	143	2	11,9	3	30110485
17,750	228	118	148	2	12,6	3	30110487
18,700	233	123	153	2	13,3	3	30110489
19,700	238	128	158	2	14,0	3	30110491
20,700	243	129	163	2	14,6	3	30110493
21,700	248	134	168	2	15,3	3	30110495
22,700	253	139	173	2	16,0	3	30110497
23,700	281	148	182	3	16,6	3	30110499
24,700	281	144	182	3	17,3	3	30110501
25,700	286	149	187	3	18,0	3	30110503
26,700	291	154	192	3	18,6	3	30110505
27,700	291	162	192	3	19,3	3	30110507
28,700	296	167	197	3	20,0	3	30110509
29,700	296	167	197	3	20,5	3	30110511
30,600	301	170	202	3	21,0	3	30110513
31,600	334	178	210	4	22,0	3	30110515
32,600	334	178	210	4	23,0	3	30110517
33,600	339	183	215	4	24,0	3	30110519
34,600	339	181	215	4	25,0	3	30110521
35,600	344	186	220	4	25,5	3	30110523
36,600	344	186	220	4	26,0	3	30110525
37,600	349	191	225	4	26,5	3	30110527
38,600	349	189	225	4	27,0	3	30110529
39,600	349	189	225	4	28,0	3	30110531
40,600	354	194	230	4	28,5	3	30110533
41,600	354	194	230	4	29,0	3	30110535

Core drill - under size I B050111, fixed design, with morse taper shank

Dimensions						z	Order no.
d ₁ h8	l ₁	l ₂	l ₄	MK	d ₅ min.		
42,600	359	197	235	4	30,0	3	30110537
43,600	359	197	235	4	30,5	3	30110539
44,600	359	197	235	4	31,0	3	30110541
45,600	364	202	240	4	32,0	3	30110543
46,600	364	200	240	4	32,5	3	30110545
47,600	369	205	245	4	33,0	3	30110547
48,600	369	205	245	4	34,0	3	30110549
49,600	369	205	245	4	34,5	3	30110551

Shell core drill, full size | B050310

Locating bore with taper 1:30 and driving slot according DIN 138 suitable for tool holders mounting on tool holder DIN 217

Design:

Diameter:

Cutting direction:

Cutting material:

Groove direction:

23.200 - 100.200 mm

Right-hand cutting

HSS (SU343)

Approx. 15° right-hand twist

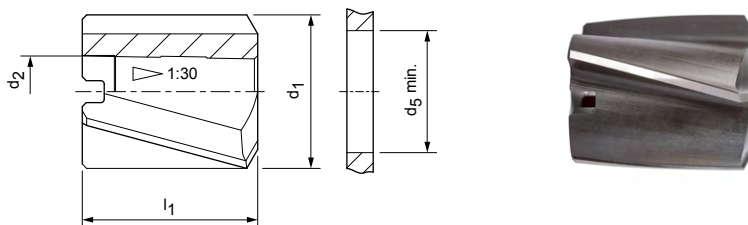

Preferred series available from stock

Dimensions				z	Order no.
d ₁ h8	l ₁	d ₂	d ₅ min.		
24,000	45	13	20	4	30110598
25,000	45	13	21	4	30110600
26,000	45	13	22	4	30110602
27,000	45	13	23	4	30110604
28,000	45	13	24	4	30110606
29,000	45	13	25	4	30110608
30,000	45	13	26	4	30110610
31,000	45	13	27	4	30110612
32,000	45	13	28	4	30110614
33,000	45	13	29	4	30110616
34,000	45	13	30	4	30110618
35,000	45	13	31	4	30110620
36,000	50	16	31	4	30110622
37,000	50	16	32	4	30110624
38,000	50	16	33	4	30110626
39,000	50	16	34	4	30110628
40,000	50	16	35	4	30110630
42,000	50	16	37	4	30110632
44,000	50	16	39	4	30110634
45,000	50	16	40	4	30110636
46,000	56	19	40	4	30110638
47,000	56	19	41	4	30110640
48,000	56	19	42	4	30110642
50,000	56	19	44	4	30110644
52,000	56	19	46	4	30110646
55,000	63	22	48	4	30110648
58,000	63	22	51	4	30110650
60,000	63	22	53	4	30110652
62,000	63	22	55	4	30110654
65,000	71	27	57	4	30110656
68,000	71	27	60	4	30110658
70,000	71	27	62	4	30110660
72,000	71	27	64	4	30110662
75,000	71	27	67	4	30110664
78,000	80	32	68	6	30110666

Shell core drill, full size I B050310, with taper 1:30

Dimensions				z	Order no.
d ₁ h8	l ₁	d ₂	d ₅ min.		
80,000	80	32	70	6	30110668
82,000	80	32	72	6	30110670
85,000	80	32	75	6	30110672
88,000	80	32	78	6	30110674
90,000	80	32	80	6	30110676
95,000	90	40	83	6	30110678
98,000	90	40	86	6	30110680
100,000	90	40	88	6	30110682

Configurable features



Bore diameter tolerance ≥ IT8:

- Diameter in increments of 0.001 mm freely selectable
- Can be ordered in tolerance ≥ IT6



Specification:
B050310[Diameter][Tolerance]

G variant (see page 303):

- Diameter in increments of 0.001 mm freely selectable
- Can be ordered from tolerances ≥ 4 μm

G variant specification:
B050310[Diameter][Tolerance]

IT8 tolerance example:
B050310-Ø37.350H6

Bore diameter d₁ = 37.350 H8

G variant example:
B050310-Ø37.350-4

Special tool diameter d₁ = 37.350 -4 μm

Dimensions of configurable series IT8

d ₁	l ₁	d ₂	d ₅ min	z
23,200-24,200	45	13	20	4
24,201-25,200	45	13	21	4
25,201-26,200	45	13	22	4
26,201-27,200	45	13	23	4
27,201-28,200	45	13	24	4
28,201-29,200	45	13	25	4
29,201-30,200	45	13	26	4
30,201-31,200	45	13	27	4
31,201-32,200	45	13	28	4
32,201-33,200	45	13	29	4
33,201-34,200	45	13	30	4
34,201-35,200	45	13	31	4
35,201-36,200	50	16	31	4
36,201-37,200	50	16	32	4
37,201-38,200	50	16	33	4
38,201-39,200	50	16	34	4
39,201-40,200	50	16	35	4
41,201-42,200	50	16	37	4
43,201-44,200	50	16	39	4
44,201-45,200	50	16	40	4
45,201-46,200	56	19	40	4
46,201-47,200	56	19	41	4
47,201-48,200	56	19	42	4
49,201-50,200	56	19	44	4
51,201-52,200	56	19	46	4
54,201-55,200	63	22	48	4
57,201-58,200	63	22	51	4
59,201-60,200	63	22	53	4
61,201-62,200	63	22	55	4
64,201-65,200	71	27	57	4
67,201-68,200	71	27	60	4
69,201-70,200	71	27	62	4
70,201-72,200	71	27	64	4
74,201-75,200	71	27	67	4
76,201-78,200	80	32	68	6
79,201-80,200	80	32	70	6
81,201-82,200	80	32	72	6
84,201-85,200	80	32	75	6
86,501-88,200	80	32	78	6
88,501-90,200	80	32	80	6
93,501-95,200	90	40	83	6
96,501-98,200	90	40	86	6
98,501-100,200	90	40	88	6

Dimensions in mm.

d₂ = nominal diameter d₁ of the matching shell holder!

Intermediate diameters that are not covered by the Ø ranges listed can be custom made on request.

Shell core drill, under size | B050311

Locating bore with taper 1:30 and driving slot according DIN 138 suitable for tool holders mounting on tool holder DIN 217

Design:

Diameter:

Cutting direction:

Cutting material:

Groove direction:

23.700 - 99.500 mm

Right-hand cutting

HSS (SU343)

Approx. 15° right-hand twist

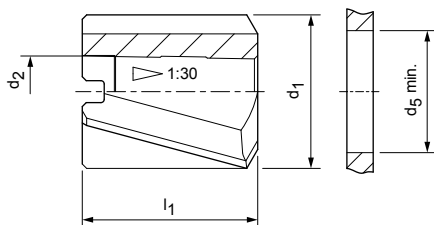
Preferred series available from stock

Dimensions				z	Order no.
d ₁ h8	l ₁	d ₂	d ₅ min.		
23,700	45	13	20	4	30110684
24,700	45	13	21	4	30110686
25,700	45	13	22	4	30110688
26,700	45	13	23	4	30110690
27,700	45	13	24	4	30110692
28,700	45	13	25	4	30110694
29,700	45	13	26	4	30110696
30,600	45	13	27	4	30110698
31,600	45	13	28	4	30110700
32,600	45	13	29	4	30110702
33,600	45	13	30	4	30110704
34,600	45	13	31	4	30110706
35,600	50	16	31	4	30110708
36,600	50	16	32	4	30110710
37,600	50	16	33	4	30110712
38,600	50	16	34	4	30110714
39,600	50	16	35	4	30110716
41,600	50	16	37	4	30110718
43,600	50	16	39	4	30110720
44,600	50	16	40	4	30110722
45,600	56	19	40	4	30110724
46,600	56	19	41	4	30110726
47,600	56	19	42	4	30110728
49,600	56	19	44	4	30110730
51,500	56	19	46	4	30110732
54,500	63	22	48	4	30110734
57,500	63	22	51	4	30110736
59,500	63	22	53	4	30110738
61,500	63	22	55	4	30110740
64,500	71	27	57	4	30110742
67,500	71	27	60	4	30110744
69,500	71	27	62	4	30110746
71,500	71	27	64	4	30110748
74,500	71	27	67	4	30110750
77,500	80	32	68	6	30110752

Shell core drill, under size I B050311, with taper 1:30

Dimensions				z	Order no.
d ₁ h8	l ₁	d ₂	d ₅ min.		
79,500	80	32	70	6	30110754
81,500	80	32	72	6	30110756
84,500	80	32	75	6	30110758
87,500	80	32	78	6	30110760
89,500	80	32	80	6	30110762
94,500	90	40	83	6	30110764
97,500	90	40	86	6	30110766
99,500	90	40	88	6	30110768

Dimensions in mm.

d₂ = nominal diameter d₁ of the matching shell holder!

Intermediate diameters that are not covered by the \emptyset ranges listed can be custom made on request.

Shell holder I B031610, B031611, B031612

Taper 1:30 with driving ring and release nut according to DIN 219, DIN 8054 and for shell core drills according to DIN 222

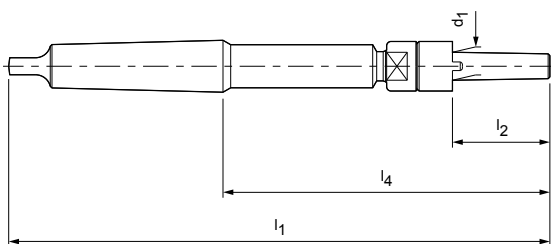

Preferred series available from stock

Dimensions								031610	031611	031612
d ₁	DIN 219	DIN 8054	DIN 222	l ₁	l ₂	l ₄	MK	Order no.	Order no.	Order no.
13,000	25-30	25-35	24-35	250	45	151	3	30107905		
16,000	31-35	36-45	36-45	261	50	162	3	30107907		
19,000	36-42	46-52	46-53	298	56	174	4	30107909		
19,000	36-42	46-52	46-53	273	56	174	3		30107921	
22,000	43-50	53-62	54-63	312	63	188	4	30107911		
22,000	43-50	53-62	54-63	287	63	188	3		30107923	
27,000	51-60	63-75	64-75	359	71	203	5	30107913		
27,000	51-60	63-75	64-75	327	71	203	4			30107925
32,000	61-71		76-90	376	80	220	5	30107915		
32,000	61-71		76-90	344	80	220	4			30107927
40,000	72-85		91-100	396	90	240	5	30107917		
50,000	86-100			416	100	260	5	30107919		

The following spare parts are also available from stock:

Driving rings | 031511

Release nuts | 031512

Washers | 031513

Notes

Cutting data recommendations for countersinks

Feed f [mm/U], cutting speed v_c [m/min]

EUC-Speed | Countersink with extremely unequal spacing

Cutting material: HSS-coated

ZG*		Workpiece material	Strength/hardness [N/mm ²] [HRC]
P	P1	P1.1 Structural, machining, case hardened and tempering steels, unalloyed	< 700 N/mm ²
		P1.2 Structural, machining, case hardened and tempering steels, unalloyed	< 1200 N/mm ²
	P2	P2.1 Nitriding, hardening and tempering steels, alloyed	< 900 N/mm ²
		P2.2 Nitriding, case-hardening and tempering steels, alloyed	< 1400 N/mm ²
	P3	P3.1 Tool steels, roller bearing steels, spring steels and high-speed steels	< 900 N/mm ²
		P3.2 Tool steels, roller bearing steels, spring steels and high-speed steels	< 1500 N/mm ²
	P4	P4.1 Stainless steels, ferritic and martensitic	
	P5	P5.1 Cast steel	
P6	P6.1 Stainless cast steels, ferritic and martensitic		
M	M1	M1.1 Stainless steels, austenitic	< 700 N/mm ²
		M1.2 Stainless steels, ferritic/austenitic (Duplex)	< 1000 N/mm ²
	M2	M2.1 Stainless cast steel, austenitic	< 700 N/mm ²
	M3	M3.1 Stainless cast steel, ferritic/austenitic (Duplex)	< 1000 N/mm ²
K	K1	K1.1 Cast iron with lamellar graphite (grey cast iron), GJL	< 300 N/mm ²
		K2.1 Cast iron with spheroidal graphite, GJS	< 500 N/mm ²
	K2	K2.2 Cast iron with spheroidal graphite, GJS	500-800 N/mm ²
		K2.3 Cast iron with spheroidal graphite, GJS	> 800 N/mm ²
	K3	K3.1 Cast iron with vermicular graphite, GJV; malleable cast iron, GJM	< 500 N/mm ²
		K3.2 Cast iron with vermicular graphite, GJV; malleable cast iron, GJM	> 500 N/mm ²
N	N1	N1.1 Aluminium, unalloyed and alloyed < 3% Si	
		N1.2 Aluminium, alloyed ≤ 7% Si	
		N1.3 Aluminium, alloyed > 7-12% Si	
		N1.4 Aluminium, alloyed > 12% Si	
	N2	N2.1 Copper, unalloyed and low alloyed	< 300 N/mm ²
		N2.2 Copper, alloyed	> 300 N/mm ²
		N2.3 Brass, bronze, gunmetal	< 1200 N/mm ²
	N3	N3.1 Graphite	
	N4	N4.1 Plastic, thermoplastics	
		N4.2 Plastic, duroplastics	
N4.3 Plastic, foam materials			
S	S1	S1.1 Titanium, titanium alloys	< 400 N/mm ²
		S2.1 Titanium, titanium alloys	< 1200 N/mm ²
	S2	S2.2 Titanium, titanium alloys	> 1200 N/mm ²
		S3.1 Nickel, unalloyed and alloyed	< 900 N/mm ²
	S3	S3.2 Nickel, unalloyed and alloyed	> 900 N/mm ²
		S4	S4.1 High-temperature super alloy, Ni-, Co-, and Fe-based
	S5	S5.1 Molybdenum and tungsten alloys	
H	H1	H1.1 Hardened steel/cast steel	45-55 HRC
		H1.2 Hardened steel/cast steel	55-64 HRC
		H1.3 Hardened steel/cast steel	64-70 HRC
	H2	H2.3 Wear-resistant cast / chill casting, GJN	

	ø < 5 [mm]		ø > 5 - 8 [mm]		ø > 8 - 12.4 [mm]		ø > 12.4 - 16.5 [mm]		ø > 16.5 - 20.5 [mm]		ø > 20.5 - 25 [mm]		ø > 25 - 31 [mm]	
	v _c	f	v _c	f	v _c	f	v _c	f	v _c	f	v _c	f	v _c	f
	40	0.06	40	0.08	40	0.10	40	0.12	40	0.14	40	0.18	40	0.22
	30	0.04	30	0.06	30	0.08	30	0.10	30	0.12	30	0.14	30	0.18
	30	0.04	30	0.06	30	0.08	30	0.10	30	0.12	30	0.14	30	0.18
	12	0.03	12	0.04	12	0.05	12	0.06	12	0.08	12	0.10	12	0.12
	30	0.04	30	0.06	30	0.08	30	0.10	30	0.12	30	0.14	30	0.18
	12	0.03	12	0.04	12	0.05	12	0.06	12	0.08	12	0.10	12	0.12
	15	0.04	15	0.05	15	0.06	15	0.07	15	0.08	15	0.09	15	0.12
	30	0.04	30	0.06	30	0.08	30	0.10	30	0.12	30	0.14	30	0.18
	15	0.04	15	0.05	15	0.06	15	0.07	15	0.08	15	0.09	15	0.12
	15	0.04	15	0.05	15	0.06	15	0.07	15	0.08	15	0.09	15	0.12
	10	0.04	10	0.05	10	0.06	10	0.07	10	0.08	10	0.09	10	0.12
	15	0.04	15	0.05	15	0.06	15	0.07	15	0.08	15	0.09	15	0.12
	20	0.06	20	0.10	20	0.12	20	0.14	20	0.18	20	0.20	20	0.25
	20	0.06	20	0.10	20	0.12	20	0.14	20	0.18	20	0.20	20	0.25
	20	0.06	20	0.10	20	0.12	20	0.14	20	0.18	20	0.20	20	0.25
	20	0.06	20	0.10	20	0.12	20	0.14	20	0.18	20	0.20	20	0.25
	20	0.06	20	0.10	20	0.12	20	0.14	20	0.18	20	0.20	20	0.25
	20	0.06	20	0.10	20	0.12	20	0.14	20	0.18	20	0.20	20	0.25
	50	0.08	50	0.10	50	0.12	50	0.14	50	0.18	50	0.22	50	0.26
	50	0.08	50	0.10	50	0.12	50	0.14	50	0.18	50	0.22	50	0.26
	40	0.08	40	0.10	40	0.12	40	0.14	40	0.18	40	0.22	40	0.26
	40	0.08	40	0.10	40	0.12	40	0.14	40	0.18	40	0.22	40	0.26
	40	0.10	40	0.12	40	0.14	40	0.18	40	0.20	40	0.24	40	0.30
	40	0.10	40	0.12	40	0.14	40	0.18	40	0.20	40	0.24	40	0.30
	40	0.10	40	0.12	40	0.14	40	0.18	40	0.20	40	0.24	40	0.30
	40	0.10	40	0.12	40	0.14	40	0.18	40	0.20	40	0.24	40	0.30
	40	0.10	40	0.12	40	0.14	40	0.18	40	0.20	40	0.24	40	0.30
	40	0.10	40	0.12	40	0.14	40	0.18	40	0.20	40	0.24	40	0.30
	10	0.04	10	0.05	10	0.06	10	0.07	10	0.08	10	0.09	10	0.12
	10	0.04	10	0.05	10	0.06	10	0.07	10	0.08	10	0.09	10	0.12
	10	0.04	10	0.05	10	0.06	10	0.07	10	0.08	10	0.09	10	0.12
	10	0.04	10	0.05	10	0.06	10	0.07	10	0.08	10	0.09	10	0.12
	10	0.04	10	0.05	10	0.06	10	0.07	10	0.08	10	0.09	10	0.12
	10	0.04	10	0.05	10	0.06	10	0.07	10	0.08	10	0.09	10	0.12
	10	0.04	10	0.05	10	0.06	10	0.07	10	0.08	10	0.09	10	0.12
	6	0.04	6	0.05	6	0.06	6	0.08	6	0.08	6	0.10		

The specified cutting data are guide values.

The optimum data for the respective machining task should be determined during the test or machining.

Next page:
Solid carbide version

Cutting data recommendations for countersinks

Feed f [mm/U], cutting speed v_c [m/min]

EUC-Speed | Countersink with extremely unequal spacing

Cutting material: Solid carbide coated

ZG*	Workpiece material	Strength/hardness [N/mm ²] [HRC]
P	P1.1 Structural, machining, case hardened and tempering steels, unalloyed	< 700 N/mm ²
	P1.2 Structural, machining, case hardened and tempering steels, unalloyed	< 1200 N/mm ²
	P2.1 Nitriding, hardening and tempering steels, alloyed	< 900 N/mm ²
	P2.2 Nitriding, case-hardening and tempering steels, alloyed	< 1400 N/mm ²
	P3.1 Tool steels, roller bearing steels, spring steels and high-speed steels	< 900 N/mm ²
	P3.2 Tool steels, roller bearing steels, spring steels and high-speed steels	< 1500 N/mm ²
	P4.1 Stainless steels, ferritic and martensitic	
	P5.1 Cast steel	
P6.1 Stainless cast steels, ferritic and martensitic		
M	M1.1 Stainless steels, austenitic	< 700 N/mm ²
	M1.2 Stainless steels, ferritic/austenitic (Duplex)	< 1000 N/mm ²
	M2.1 Stainless cast steel, austenitic	< 700 N/mm ²
	M3.1 Stainless cast steel, ferritic/austenitic (Duplex)	< 1000 N/mm ²
K	K1.1 Cast iron with lamellar graphite (grey cast iron), GJL	< 300 N/mm ²
	K2.1 Cast iron with spheroidal graphite, GJS	< 500 N/mm ²
	K2.2 Cast iron with spheroidal graphite, GJS	500-800 N/mm ²
	K2.3 Cast iron with spheroidal graphite, GJS	> 800 N/mm ²
	K3.1 Cast iron with vermicular graphite, GJV; malleable cast iron, GJM	< 500 N/mm ²
	K3.2 Cast iron with vermicular graphite, GJV; malleable cast iron, GJM	> 500 N/mm ²
N	N1.1 Aluminium, unalloyed and alloyed < 3% Si	
	N1.2 Aluminium, alloyed ≤ 7% Si	
	N1.3 Aluminium, alloyed > 7-12% Si	
	N1.4 Aluminium, alloyed > 12% Si	
	N2.1 Copper, unalloyed and low alloyed	< 300 N/mm ²
	N2.2 Copper, alloyed	> 300 N/mm ²
	N2.3 Brass, bronze, gunmetal	< 1200 N/mm ²
	N3.1 Graphite	
	N4.1 Plastic, thermoplastics	
	N4.2 Plastic, duroplastics	
N4.3 Plastic, foam materials		
C	C1.1 Plastic range, reinforced with aramid fibre (AFK)	
	C1.2 Plastic range (duroplastic), CFK/GFK	
	C1.3 Plastic range (thermoplastic), CFK/GFK	
	C2.1 Carbon range, reinforced with carbon fibre (CFC)	
	C3.1 Metal matrix (MMC)	
	C4.1 Sandwich construction, honeycomb core made from paper	
	C4.2 Sandwich construction, honeycomb core made from aluminium	
	C4.3 Sandwich construction, honeycomb core made from plastic and fibre composite material	
	C4.4 Sandwich construction, core made from rigid foam sheets	
	C5.1 Stack (hybrid structure), CFK aluminium	
C5.2 Stack (hybrid structure), CFK titanium/stainless steel		
S	S1.1 Titanium, titanium alloys	< 400 N/mm ²
	S2.1 Titanium, titanium alloys	< 1200 N/mm ²
	S2.2 Titanium, titanium alloys	> 1200 N/mm ²
	S3.1 Nickel, unalloyed and alloyed	< 900 N/mm ²
	S3.2 Nickel, unalloyed and alloyed	> 900 N/mm ²
	S4.1 High-temperature super alloy, Ni-, Co-, and Fe-based	
	S5.1 Molybdenum and tungsten alloys	
H	H1.1 Hardened steel/cast steel	45-55 HRC
	H1.2 Hardened steel/cast steel	55-64 HRC
	H1.3 Hardened steel/cast steel	64-70 HRC
	H2.3 Wear-resistant cast / chill casting, GJN	

	Ø < 5 [mm]		Ø < 5-8 [mm]		Ø < 8 - 12.4 [mm]		Ø < 12.4 - 16.5 [mm]		Ø < 16.5 - 20.5 [mm]		Ø < 20.5 - 25 [mm]		Ø < 25 - 31 [mm]	
	v _c	f	v _c	f	v _c	f	v _c	f	v _c	f	v _c	f	v _c	f
	60	0.06	60	0.08	60	0.10	60	0.12	60	0.14	60	0.18	60	0.22
	50	0.04	50	0.06	50	0.08	50	0.10	50	0.12	50	0.14	50	0.18
	50	0.04	50	0.06	50	0.08	50	0.10	50	0.12	50	0.14	50	0.18
	40	0.03	40	0.04	40	0.05	40	0.06	40	0.08	40	0.10	40	0.12
	50	0.04	50	0.06	50	0.08	50	0.10	50	0.12	50	0.14	50	0.18
	40	0.03	40	0.04	40	0.05	40	0.06	40	0.08	40	0.10	40	0.12
	30	0.04	30	0.05	30	0.06	30	0.07	30	0.08	30	0.09	30	0.12
	50	0.04	50	0.06	50	0.08	50	0.10	50	0.12	50	0.14	50	0.18
	30	0.04	30	0.05	30	0.06	30	0.07	30	0.08	30	0.09	30	0.12
	30	0.04	30	0.05	30	0.06	30	0.07	30	0.08	30	0.09	30	0.12
	25	0.04	25	0.05	25	0.06	25	0.07	25	0.08	25	0.09	25	0.12
	30	0.04	30	0.05	30	0.06	30	0.07	30	0.08	30	0.09	30	0.12
	25	0.04	25	0.05	25	0.06	25	0.07	25	0.08	25	0.09	25	0.12
	50	0.06	50	0.10	50	0.12	50	0.14	50	0.18	50	0.20	50	0.25
	45	0.06	45	0.10	45	0.12	45	0.14	45	0.18	45	0.20	45	0.25
	45	0.06	45	0.10	45	0.12	45	0.14	45	0.18	45	0.20	45	0.25
	45	0.06	45	0.10	45	0.12	45	0.14	45	0.18	45	0.20	45	0.25
	35	0.06	35	0.10	35	0.12	35	0.14	35	0.18	35	0.20	35	0.25
	35	0.06	35	0.10	35	0.12	35	0.14	35	0.18	35	0.20	35	0.25
	80	0.08	80	0.10	80	0.12	80	0.14	80	0.18	80	0.22	80	0.26
	80	0.08	80	0.10	80	0.12	80	0.14	80	0.18	80	0.22	80	0.26
	60	0.08	60	0.10	60	0.12	60	0.14	60	0.18	60	0.22	60	0.26
	60	0.08	60	0.10	60	0.12	60	0.14	60	0.18	60	0.22	60	0.26
	70	0.10	70	0.12	70	0.14	70	0.18	70	0.20	70	0.24	70	0.30
	70	0.10	70	0.12	70	0.14	70	0.18	70	0.20	70	0.24	70	0.30
	70	0.10	70	0.12	70	0.14	70	0.18	70	0.20	70	0.24	70	0.30
	25	0.06	25	0.10	25	0.12	25	0.14	25	0.18	25	0.20	25	0.25
	70	0.10	70	0.12	70	0.14	70	0.18	70	0.20	70	0.24	70	0.30
	70	0.10	70	0.12	70	0.14	70	0.18	70	0.20	70	0.24	70	0.30
	70	0.10	70	0.12	70	0.14	70	0.18	70	0.20	70	0.24	70	0.30
	25	0.06	25	0.10	25	0.12	25	0.14	25	0.18	25	0.20	25	0.25
	25	0.06	25	0.10	25	0.12	25	0.14	25	0.18	25	0.20	25	0.25
	25	0.06	25	0.10	25	0.12	25	0.14	25	0.18	25	0.20	25	0.25
	25	0.06	25	0.10	25	0.12	25	0.14	25	0.18	25	0.20	25	0.25
	25	0.06	25	0.10	25	0.12	25	0.14	25	0.18	25	0.20	25	0.25
	25	0.06	25	0.10	25	0.12	25	0.14	25	0.18	25	0.20	25	0.25
	25	0.06	25	0.10	25	0.12	25	0.14	25	0.18	25	0.20	25	0.25
	25	0.06	25	0.10	25	0.12	25	0.14	25	0.18	25	0.20	25	0.25
	25	0.06	25	0.10	25	0.12	25	0.14	25	0.18	25	0.20	25	0.25
	25	0.06	25	0.10	25	0.12	25	0.14	25	0.18	25	0.20	25	0.25
	15	0.05	15	0.06	15	0.07	15	0.08	15	0.09	15	0.10	15	0.12
	15	0.05	15	0.06	15	0.07	15	0.08	15	0.09	15	0.10	15	0.12
	15	0.05	15	0.06	15	0.07	15	0.08	15	0.09	15	0.10	15	0.12
	15	0.05	15	0.06	15	0.07	15	0.08	15	0.09	15	0.10	15	0.12
	15	0.05	15	0.06	15	0.07	15	0.08	15	0.09	15	0.10	15	0.12
	15	0.05	15	0.06	15	0.07	15	0.08	15	0.09	15	0.10	15	0.12
	12	0.04	12	0.05	12	0.06	12	0.08	12	0.08	12	0.10		
	8	0.04	8	0.05	8	0.06	8	0.08	8	0.08	8	0.10		
	12	0.04	12	0.05	12	0.06	12	0.08	12	0.08	12	0.10		

Cutting data recommendations for countersinks

Feed f [mm/U], cutting speed v_c [m/min]

90°

Cutting material: Solid carbide, uncoated

ZG*		Workpiece material	Strength/hardness [N/mm ²] [HRC]
P	P1	P1.1 Structural, machining, case hardened and tempering steels, unalloyed	< 700 N/mm ²
		P1.2 Structural, machining, case hardened and tempering steels, unalloyed	< 1200 N/mm ²
	P2	P2.1 Nitriding, hardening and tempering steels, alloyed	< 900 N/mm ²
		P2.2 Nitriding, case-hardening and tempering steels, alloyed	< 1400 N/mm ²
	P3	P3.1 Tool steels, roller bearing steels, spring steels and high-speed steels	< 900 N/mm ²
		P3.2 Tool steels, roller bearing steels, spring steels and high-speed steels	< 1500 N/mm ²
	P4	P4.1 Stainless steels, ferritic and martensitic	
	P5	P5.1 Cast steel	
P6	P6.1 Stainless cast steels, ferritic and martensitic		
M	M1	M1.1 Stainless steels, austenitic	< 700 N/mm ²
		M1.2 Stainless steels, ferritic/austenitic (Duplex)	< 1000 N/mm ²
	M2	M2.1 Stainless cast steel, austenitic	< 700 N/mm ²
	M3	M3.1 Stainless cast steel, ferritic/austenitic (Duplex)	< 1000 N/mm ²
K	K1	K1.1 Cast iron with lamellar graphite (grey cast iron), GJL	< 300 N/mm ²
		K2.1 Cast iron with spheroidal graphite, GJS	< 500 N/mm ²
	K2	K2.2 Cast iron with spheroidal graphite, GJS	500-800 N/mm ²
		K2.3 Cast iron with spheroidal graphite, GJS	> 800 N/mm ²
	K3	K3.1 Cast iron with vermicular graphite, GJV; malleable cast iron, GJM	< 500 N/mm ²
		K3.2 Cast iron with vermicular graphite, GJV; malleable cast iron, GJM	> 500 N/mm ²
N	N1	N1.1 Aluminium, unalloyed and alloyed < 3% Si	
		N1.2 Aluminium, alloyed ≤ 7% Si	
		N1.3 Aluminium, alloyed > 7-12% Si	
		N1.4 Aluminium, alloyed > 12% Si	
	N2	N2.1 Copper, unalloyed and low alloyed	< 300 N/mm ²
		N2.2 Copper, alloyed	> 300 N/mm ²
		N2.3 Brass, bronze, gunmetal	< 1200 N/mm ²
	N3	N3.1 Graphite	
	N4	N4.1 Plastic, thermoplastics	
		N4.2 Plastic, duroplastics	
N4.3 Plastic, foam materials			
S	S1	S1.1 Titanium, titanium alloys	< 400 N/mm ²
		S2.1 Titanium, titanium alloys	< 1200 N/mm ²
	S2	S2.2 Titanium, titanium alloys	> 1200 N/mm ²
		S3.1 Nickel, unalloyed and alloyed	< 900 N/mm ²
	S3	S3.2 Nickel, unalloyed and alloyed	> 900 N/mm ²
		S4	S4.1 High-temperature super alloy, Ni-, Co-, and Fe-based
S5	S5.1 Molybdenum and tungsten alloys		
H	H1	H1.1 Hardened steel/cast steel	45-55 HRC
		H1.2 Hardened steel/cast steel	55-64 HRC
		H1.3 Hardened steel/cast steel	64-70 HRC
	H2	H2.3 Wear-resistant cast / chill casting, GJN	

	ø > 5 - 8 [mm]		ø > 8 - 12.4 [mm]		ø > 12.4 - 16.5 [mm]		ø > 16.5 - 20.5 [mm]		ø > 20.5 - 25 [mm]		ø > 25 - 31 [mm]	
	v _c	f	v _c	f	v _c	f	v _c	f	v _c	f	v _c	f
	40	0.08	40	0.10	40	0.12	40	0.14	40	0.18	40	0.22
	18	0.04	18	0.05	18	0.06	18	0.08	18	0.10	18	0.12
	30	0.06	30	0.08	30	0.10	30	0.12	30	0.14	30	0.18
	18	0.04	18	0.05	18	0.06	18	0.08	18	0.10	18	0.12
	30	0.06	30	0.08	30	0.10	30	0.12	30	0.14	30	0.18
	18	0.04	18	0.05	18	0.06	18	0.08	18	0.10	18	0.12
	16	0.05	16	0.06	16	0.07	16	0.08	16	0.09	16	0.12
	30	0.06	30	0.08	30	0.10	30	0.12	30	0.14	30	0.18
	16	0.05	16	0.06	16	0.07	16	0.08	16	0.10	16	0.12
	16	0.05	16	0.06	16	0.07	16	0.08	16	0.09	16	0.12
	16	0.05	16	0.06	16	0.07	16	0.08	16	0.09	16	0.12
	16	0.05	16	0.06	16	0.07	16	0.08	16	0.09	16	0.12
	25	0.10	25	0.12	25	0.14	25	0.18	25	0.20	25	0.25
	25	0.10	25	0.12	25	0.14	25	0.18	25	0.20	25	0.25
	18	0.10	18	0.12	18	0.14	18	0.18	18	0.20	18	0.25
	18	0.10	18	0.12	18	0.14	18	0.18	18	0.20	18	0.25
	25	0.10	25	0.12	25	0.14	25	0.18	25	0.20	25	0.25
	18	0.10	18	0.12	18	0.14	18	0.18	18	0.20	18	0.25
	60	0.10	60	0.12	60	0.14	60	0.18	60	0.22	60	0.26
	60	0.10	60	0.12	60	0.14	60	0.18	60	0.22	60	0.26
	45	0.10	45	0.12	45	0.14	45	0.18	45	0.22	45	0.26
	45	0.10	45	0.12	45	0.14	45	0.18	45	0.22	45	0.26
	50	0.12	50	0.14	50	0.18	50	0.20	50	0.20	50	0.30
	50	0.12	50	0.14	50	0.18	50	0.20	50	0.20	50	0.30
	50	0.12	50	0.14	50	0.18	50	0.20	50	0.20	50	0.30
	50	0.12	50	0.14	50	0.18	50	0.20	50	0.20	50	0.30
	50	0.12	50	0.14	50	0.18	50	0.20	50	0.20	50	0.30
	50	0.12	50	0.14	50	0.18	50	0.20	50	0.20	50	0.30
	12	0.04	12	0.05	12	0.06	12	0.07	12	0.08	12	0.10
	12	0.04	12	0.05	12	0.06	12	0.07	12	0.08	12	0.10
	12	0.04	12	0.05	12	0.06	12	0.07	12	0.08	12	0.10
	12	0.04	12	0.05	12	0.06	12	0.07	12	0.08	12	0.10
	12	0.04	12	0.05	12	0.06	12	0.07	12	0.08	12	0.10
	12	0.04	12	0.05	12	0.06	12	0.07	12	0.08	12	0.10
	12	0.04	12	0.05	12	0.06	12	0.07	12	0.08	12	0.10
	8	0.05	8	0.06	8	0.08	8	0.08	8	0.10	8	0.12
	---	---	---	---	---	---	---	---	---	---	---	---
	---	---	---	---	---	---	---	---	---	---	---	---
	---	---	---	---	---	---	---	---	---	---	---	---

The specified cutting data are guide values.

The optimum data for the respective machining task should be determined during the test or machining.

Cutting data recommendations for countersinks

Feed f [mm/U], cutting speed v_c [m/min]

90° and 60°

Cutting material: HSS, coated and uncoated

ZG*	Workpiece material	Strength/hardness [N/mm ²] [HRC]
P	P1.1 Structural, machining, case hardened and tempering steels, unalloyed	< 700 N/mm ²
	P1.2 Structural, machining, case hardened and tempering steels, unalloyed	< 1200 N/mm ²
	P2.1 Nitriding, hardening and tempering steels, alloyed	< 900 N/mm ²
	P2.2 Nitriding, case-hardening and tempering steels, alloyed	< 1400 N/mm ²
	P3.1 Tool steels, roller bearing steels, spring steels and high-speed steels	< 900 N/mm ²
	P3.2 Tool steels, roller bearing steels, spring steels and high-speed steels	< 1500 N/mm ²
	P4.1 Stainless steels, ferritic and martensitic	
	P5.1 Cast steel	
P6.1 Stainless cast steels, ferritic and martensitic		
M	M1.1 Stainless steels, austenitic	< 700 N/mm ²
	M1.2 Stainless steels, ferritic/austenitic (Duplex)	< 1000 N/mm ²
	M2.1 Stainless cast steel, austenitic	< 700 N/mm ²
	M3.1 Stainless cast steel, ferritic/austenitic (Duplex)	< 1000 N/mm ²
K	K1.1 Cast iron with lamellar graphite (grey cast iron), GJL	< 300 N/mm ²
	K2.1 Cast iron with spheroidal graphite, GJS	< 500 N/mm ²
	K2.2 Cast iron with spheroidal graphite, GJS	500-800 N/mm ²
	K2.3 Cast iron with spheroidal graphite, GJS	> 800 N/mm ²
	K3.1 Cast iron with vermicular graphite, GJV; malleable cast iron, GJM	< 500 N/mm ²
	K3.2 Cast iron with vermicular graphite, GJV; malleable cast iron, GJM	> 500 N/mm ²
N	N1.1 Aluminium, unalloyed and alloyed < 3% Si	
	N1.2 Aluminium, alloyed ≤ 7% Si	
	N1.3 Aluminium, alloyed > 7-12% Si	
	N1.4 Aluminium, alloyed > 12% Si	
	N2.1 Copper, unalloyed and low alloyed	< 300 N/mm ²
	N2.2 Copper, alloyed	> 300 N/mm ²
	N2.3 Brass, bronze, gunmetal	< 1200 N/mm ²
	N3.1 Graphite	
	N4.1 Plastic, thermoplastics	
	N4.2 Plastic, duroplastics	
N4.3 Plastic, foam materials		
S	S1.1 Titanium, titanium alloys	< 400 N/mm ²
	S2.1 Titanium, titanium alloys	< 1200 N/mm ²
	S2.2 Titanium, titanium alloys	> 1200 N/mm ²
	S3.1 Nickel, unalloyed and alloyed	< 900 N/mm ²
	S3.2 Nickel, unalloyed and alloyed	> 900 N/mm ²
	S4.1 High-temperature super alloy, Ni-, Co-, and Fe-based	
	S5.1 Molybdenum and tungsten alloys	
H	H1.1 Hardened steel/cast steel	45-55 HRC
	H1.2 Hardened steel/cast steel	55-64 HRC
	H1.3 Hardened steel/cast steel	64-70 HRC
	H2.3 Wear-resistant cast / chill casting, GJN	

	Ø > 5 [mm]		Ø > 5 - 8 [mm]		Ø > 8 - 12.4 [mm]		Ø > 12.4 - 16.5 [mm]		Ø > 16.5 - 20.5 [mm]		Ø > 20.5 - 25 [mm]		Ø > 25 - 40 [mm]		Ø > 40 - 63 [mm]		Ø > 63 - 100 [mm]	
	v _c	f	v _c	f	v _c	f	v _c	f	v _c	f	v _c	f	v _c	f	v _c	f	v _c	f
	30	0.06	30	0.08	30	0.10	30	0.12	30	0.14	30	0.18	30	0.22	30	0.30	30	0.35
	10	0.03	10	0.04	10	0.05	10	0.06	10	0.08	10	0.10	10	0.12	10	0.16	10	0.20
	25	0.04	25	0.06	25	0.08	25	0.10	25	0.12	25	0.14	25	0.18	25	0.25	25	0.30
	10	0.03	10	0.04	10	0.05	10	0.06	10	0.08	10	0.10	10	0.12	10	0.16	10	0.20
	10	0.03	10	0.04	10	0.05	10	0.06	10	0.08	10	0.10	10	0.12	10	0.16	10	0.20
	10	0.03	10	0.04	10	0.05	10	0.06	10	0.08	10	0.10	10	0.12	10	0.16	10	0.20
	25	0.04	25	0.06	25	0.08	25	0.10	25	0.12	25	0.14	25	0.18	25	0.25	25	0.30
	8	0.04	8	0.05	8	0.06	8	0.07	8	0.08	8	0.09	8	0.12	8	0.14	8	0.20
	8	0.04	8	0.05	8	0.06	8	0.07	8	0.08	8	0.09	8	0.12	8	0.14	8	0.20
	8	0.04	8	0.05	8	0.06	8	0.07	8	0.08	8	0.09	8	0.12	8	0.14	8	0.20
	8	0.04	8	0.05	8	0.06	8	0.07	8	0.08	8	0.09	8	0.12	8	0.14	8	0.20
	12	0.06	12	0.10	12	0.12	12	0.14	12	0.18	12	0.20	12	0.25	12	0.28	12	0.33
	12	0.06	12	0.10	12	0.12	12	0.14	12	0.18	12	0.20	12	0.25	12	0.28	12	0.33
	10	0.06	10	0.10	10	0.12	10	0.14	10	0.18	10	0.20	10	0.25	10	0.28	10	0.33
	10	0.06	10	0.10	10	0.12	10	0.14	10	0.18	10	0.20	10	0.25	10	0.28	10	0.33
	12	0.06	12	0.10	12	0.12	12	0.14	12	0.18	12	0.20	12	0.25	12	0.28	12	0.33
	10	0.06	10	0.10	10	0.12	10	0.14	10	0.18	10	0.20	10	0.25	10	0.28	10	0.33
	35	0.08	35	0.10	35	0.12	35	0.14	35	0.18	35	0.22	35	0.26	35	0.30	35	0.35
	35	0.08	35	0.10	35	0.12	35	0.14	35	0.18	35	0.22	35	0.26	35	0.30	35	0.35
	25	0.08	25	0.10	25	0.12	25	0.14	25	0.18	25	0.22	25	0.26	25	0.30	25	0.35
	25	0.08	25	0.10	25	0.12	25	0.14	25	0.18	25	0.22	25	0.26	25	0.30	25	0.35
	35	0.10	35	0.12	35	0.14	35	0.18	35	0.20	35	0.24	35	0.30	35	0.40	35	0.45
	35	0.10	35	0.12	35	0.14	35	0.18	35	0.20	35	0.24	35	0.30	35	0.40	35	0.45
	35	0.10	35	0.12	35	0.14	35	0.18	35	0.20	35	0.24	35	0.30	35	0.40	35	0.45
	35	0.10	35	0.12	35	0.14	35	0.18	35	0.20	35	0.24	35	0.30	35	0.40	35	0.45
	8	0.04	8	0.05	8	0.06	8	0.07	8	0.08	8	0.09	8	0.12	8	0.14	8	0.18
	8	0.04	8	0.05	8	0.06	8	0.07	8	0.08	8	0.09	8	0.12	8	0.14	8	0.18
	8	0.04	8	0.05	8	0.06	8	0.07	8	0.08	8	0.09	8	0.12	8	0.14	8	0.18
	8	0.04	8	0.05	8	0.06	8	0.07	8	0.08	8	0.09	8	0.12	8	0.14	8	0.18
	8	0.04	8	0.05	8	0.06	8	0.07	8	0.08	8	0.09	8	0.12	8	0.14	8	0.18
	8	0.04	8	0.05	8	0.06	8	0.07	8	0.08	8	0.09	8	0.12	8	0.14	8	0.18
	8	0.04	8	0.05	8	0.06	8	0.07	8	0.08	8	0.09	8	0.12	8	0.14	8	0.18
	4	0.04	4	0.05	4	0.06	4	0.08	4	0.10								

The specified cutting data are guide values.

The optimum data for the respective machining task should be determined during the test or machining.

TECHNICAL APPENDIX

Notes on application and handling.



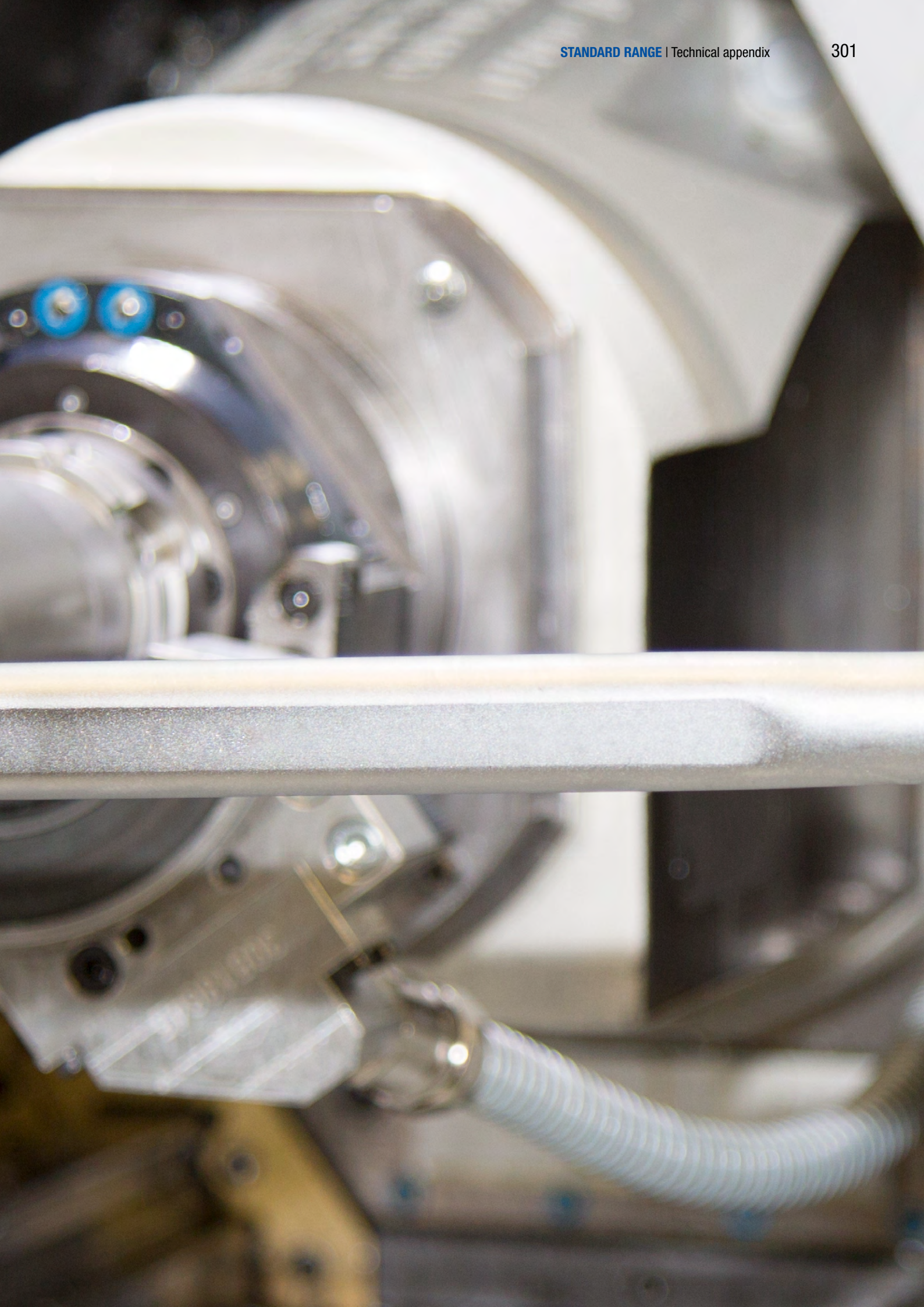

Lead geometries, rake angles and tolerances for high-performance reamers

Lead geometries and rake angles for high-performance reamers

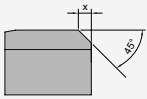
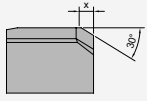
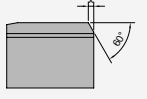
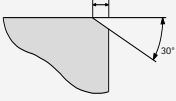
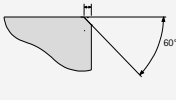
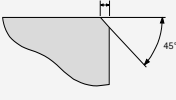
Series	Geometry	Lead geometry				
		Series	Lead	∅ area	Lead length x	Geometry
HNC-Plus		B043565	MJ	3.701 - 4.200 mm	0.30 mm	45°
		B043575, B043585	MM	4.201 - 4.700 mm	0.40 mm	
		B043555	MQ	4.701 - 20.200 mm	0.55 mm	
FixReam 700		B042200, B042700	LA	9.900 - 11.700 mm	0.80 mm	30°
				11.701 - 32.200 mm	1.00 mm	
		B042201, B042701	LB	9.900 - 32.000 mm	0.25 mm	60°
HNC		B040260, B043260, B043250	MG	2.810 - 3.700 mm	0.70 mm	30°
				3.710 - 6.200 mm	0.90 mm	
				6.210 - 12.200 mm	1.20 mm	
		12.210 - 20.200 mm	1.50 mm			
		B043270, B043290, B043280, B043272	MF	2.810 - 3.700 mm	0.70 mm	
				3.710 - 6.200 mm	0.90 mm	
	6.210 - 12.200 mm			1.20 mm		
		B040261, B043261, B043291, B043251	MV	2.810 - 6.200 mm	0.30 mm	60°
				6.210 - 10.700 mm	0.40 mm	
				10.710 - 16.200 mm	0.50 mm	
	B043271, B043281, B043273	MT	16.210 - 20.200 mm	0.60 mm		
			2.810 - 6.200 mm	0.30 mm	60°	
			6.210 - 10.700 mm	0.40 mm		
		B043265	MC	10.710 - 16.200 mm		0.50 mm
				16.210 - 20.200 mm	0.60 mm	
2.810 - 3.350 mm				0.30 mm		
3.360 - 4.050 mm				0.40 mm		
4.060 - 5.600 mm				0.50 mm		
5.610 - 6.600 mm				0.60 mm		
B040356	MH	6.610 - 7.600 mm	0.70 mm	45°		
		7.610 - 11.600 mm	0.80 mm			
		11.610 - 20.100 mm	1.00 mm			
B040356	MH	MH	3.001 - 3.710 mm	0.15 mm	45°	
			3.711 - 6.210 mm	0.25 mm		
			6.211 - 10.200 mm	0.30 mm		
B40366	MI	MI	3.001 - 3.710 mm	0.10 mm	60°	
			3.711 - 6.210 mm	0.15 mm		
			6.211 - 10.200 mm	0.20 mm		

Tolerances for the G variant/fixed variant FXRXX

Cutting material	Tolerance
Uncoated CU111	-0.003
Coated (layer thickness 0.8–1 µm) HP622	-0.004
Coated (layer thickness 2–4 µm) HP141 HP900	-0.005

Chip shape / rake angle

Rake angle	
Description	Angle
1G	6°

G variant

The G variant indicates the tool diameter of the reamer with our manufacturing tolerances. The manufacturing tolerances depend on the cutting material (see permissible smallest tolerances for the G variant).

Handling notes for replaceable heads XR 01, XR 06

The universal replaceable heads in the XR series are part of a complete and particularly user-friendly range. The XS connection ensures the replaceable heads can be changed quickly and easily with high accuracy of repetition. At the same time, perfect retention with maximum stability and rigidity is achieved.

The replaceable head is tightened to the stipulated tightening torque and produces a joint with force and form fit. The key features of this system are high radial run-out accuracy in conjunction with very good rigidity.

Assembly of the replaceable heads XR

Note:

To minimise the risk of injuries, it is recommended to wear gloves for the following actions.

Comment:

For trained personnel only.

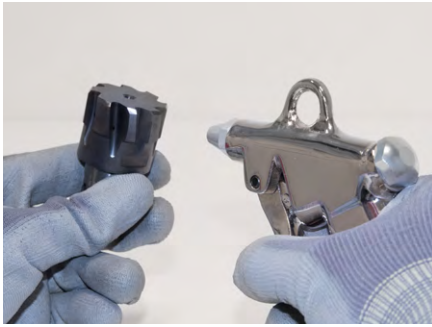

1. Clean the taper, thread and face surface on the replaceable head using compressed air and a cloth.



2. Clean the taper, thread and face surface on the replaceable head holder using compressed air and a cloth.

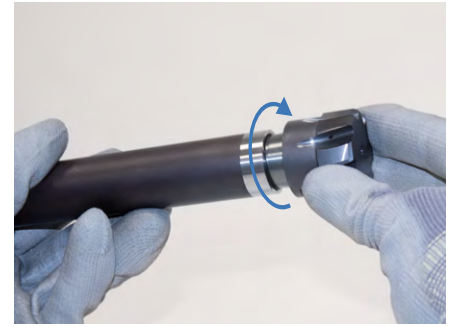

3. Screw the replaceable head clockwise into the replaceable head holder so it is hand-tight. Then clamp the replaceable head holder with the tool in the machine holder.

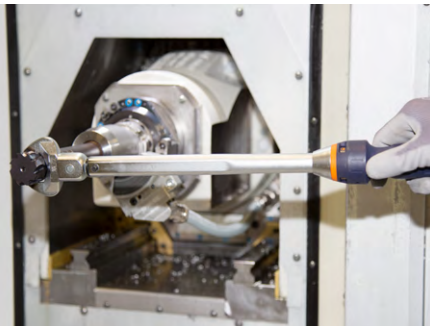

4. Place the torque wrench on the replaceable head so it is as horizontal as possible; do not tilt the faces on the wrench.



5. Tighten the replaceable head to the stated tightening torque with the aid of the torque wrench and the appropriate combination wrench (see table "Tightening torques for the replaceable heads").



Result:

The gap between the replaceable head and replaceable head holder is closed and a joint with a force and form fit is formed. The replaceable head XR is now ready to use.

Tightening torques for replaceable heads

Connection size XS	Tightening torque [Nm]
6	5
8	12,5
10	15
12	20
16	25
20	30

BECK machining groups

Machining group	Workpiece material	Strength/hardness [N/mm ²] [HRC]	Frequently machined workpiece materials	
P	P1.1	Structural, machining, case hardened and tempering steels, unalloyed	< 700 N/mm ²	1.0122 (S235/St 37), 1.0401 (C15), 1.0503 (C45), 1.0570 (S355/St 52), 1.1213 (Cf53)
	P1.2	Structural, machining, case hardened and tempering steels, unalloyed	< 1,200 N/mm ²	1.1249 (Cf70)
	P2.1	Nitriding, hardening and tempering steels, alloyed	< 900 N/mm ²	1.7131 (16MnCr5)
	P2.2	Nitriding, hardening and tempering steels, alloyed	< 1,400 N/mm ²	1.7227 (42CrMoS4)
	P3.1	Tool steels, roller bearing steels, spring steels and high-speed steels*	< 800 N/mm ²	1.2343 (X37CrMoV5-1), 1.2762 (75CrMoNiW6-7)
	P3.2	Tool steels, roller bearing steels, spring steels and high-speed steels*	< 1,000 N/mm ²	1.2367 (X38CrMoV5-3), 1.2713 (55NiCrMoV6)
	P3.3	Tool steels, roller bearing steels, spring steels and high-speed steels*	< 1,500 N/mm ²	1.2379 (X153CrMoV12) 1.2738 (40CrMnNiMo8-6-4)
	P4.1	Stainless steels, ferritic and martensitic		1.4510 (X3CrTi17), 1.4589 (X5CrNiMoTi15-2)
	P5.1	Cast steel		1.7231 (G42CrMo4)
	P6.1	Stainless cast steels, ferritic and martensitic		
M	M1.1	Stainless steels, austenitic	< 700 N/mm ²	1.4301 (V2A), 1.4571 (V4A)
	M1.2	Stainless steels, ferritic/austenitic (duplex)	< 1,000 N/mm ²	1.4362 (Alloy 2304), 1.4501, 1.4662 (LDX 2404)
	M2.1	Stainless cast steel, austenitic	< 700 N/mm ²	
M3.1	Stainless cast steel, ferritic/austenitic (duplex)	< 1,000 N/mm ²		
K	K1.1	Cast iron with lamellar graphite (grey cast iron), GJL	< 300 N/mm ²	GJL-250 (GG-25), GJL-260 (GG-26 Cr)
	K2.1	Cast iron with spheroidal graphite, GJS	< 500 N/mm ²	GJS-400 (GGG-40), GJS-450 (GGG-45)
	K2.2	Cast iron with spheroidal graphite, GJS	≤ 800 N/mm ²	GJS-600 (GGG-60), GJS-800-2 (GGG-80), GJS-800-8 (ADI 800)
	K2.3	Cast iron with spheroidal graphite, GJS	> 800 N/mm ²	GJS-900-2 (GGG-90), GJS-1000-5 (ADI 1000), GJS-1200-2 (ADI 1200), GJS-1400-1 (ADI 1400)
	K3.1	Cast iron with vermicular graphite, GJV; malleable cast iron, GJM	< 500 N/mm ²	GJV-300, GJV-400, GJMW-400-5 (GTW-40)
K3.2	Cast iron with vermicular graphite, GJV; malleable cast iron, GJM	> 500 N/mm ²	GJV-500, GJV-700	
N	N1.1	Aluminium, unalloyed and alloyed < 3% Si		Alloy 2024, Alloy 7075, Al99
	N1.2	Aluminium, alloyed ≤ 7% Si		AlSi7
	N1.3	Aluminium, alloyed > 7 - 12% Si		AlSi9, AlSi9Cu
	N1.4	Aluminium, alloyed > 12% Si		AlSi12, AlSi17
	N2.1	Copper, unalloyed and low alloyed	< 300 N/mm ²	SE-Cu
	N2.2	Copper, alloyed	> 300 N/mm ²	CuSn6
	N2.3	Brass, bronze, gunmetal	< 1,200 N/mm ²	CuZn33, CuAl9Mn3
	N3.1	Graphite, > 8 µm		
	N3.2	Graphite, ≤ 8 µm		
	N4.1	Plastic, thermoplastics		PA, PE, PC, PS, PVC, PP, PTFE, POM, PMMA
N4.2	Plastic, duroplastics		PU, PF, EP, UP, VE, CR	
N4.3	Plastic, foam materials		EPS, PUR, PVC-E, PS-E, PP-E	
C	C1.1	Plastic range, reinforced with aramid fibre (AFK)		Nomex, Kevlar, Twaron, KOREX
	C1.2	Plastic range (duroplastic), CFK/GFK		IMS, HTA
	C1.3	Plastic range (thermoplastic), CFK/GFK		GMT-PP, PEEK
	C2.1	Carbon range, reinforced with carbon fibre (CFC)		CF222, CF225, CF226, CF227, CF260
	C3.1	Metal matrix (MMC)		CeramTec AO-403 (AlSi9MgMn-Al2O3), Al/Cu/Mg-SiO2/Al2O3/AlN/TiC/SiC/BN/TiB2
	C4.1	Sandwich construction, honeycomb core (Honeycomb)		
	C4.2	Sandwich construction, foam core		PLASCORE PAMG-XR1 5052, PCGA-XR1 3003, PAMG-XR1 5056, Micro-Cell (core made of alloy 5052/5056)
	C5.1	Multilayer composite (stack), non-metallic non-ferrous metal composite		CFK-aluminium, IMS/HTA + Alloy 2024/6061/7075
	C5.2	Multilayer composite (stack), non-metallic metal composite		CFK-titanium, IMS/HTA + TiAl6V4/AMS4905
	C5.3	Multilayer composite (stack), non-metallic non-metal composite		CFK-CFK
C5.4	Multilayer composite (stack), non-ferrous metallic non-ferrous metal composite		Aluminium-aluminium	
C5.5	Multilayer composite (stack), non-ferrous metallic metal composite		Aluminium-titanium	
C5.6	Multilayer composite (stack), metallic metal composite		Titanium Inox	
S	S1.1	Titanium, titanium alloys	< 400 N/mm ²	
	S2.1	Titanium, titanium alloys	< 1,200 N/mm ²	TiAl6V4
	S2.2	Titanium, titanium alloys	> 1,200 N/mm ²	
	S3.1	Nickel, unalloyed and alloyed	< 900 N/mm ²	1.3912 (Invar, Ni36)
	S3.2	Nickel, unalloyed and alloyed	> 900 N/mm ²	
S4.1	High-temperature super alloy, Ni-, Co-, and Fe-based		Hardox, Hastelloy, Incoloy, Inconel, NIMONIC, Stellite, Waspaloy	
S5.1	Molybdenum and tungsten alloys			
H	H1.1	Hardened steel / cast steel	< 44 HRC	1.2738 HH, 1.2085, Toolox 33, Toolox 44
	H1.2	Hardened steel / cast steel	< 55 HRC	1.2343, 1.2311, 1.2312, 1.2714, 1.2083, 1.2738
	H2.1	Hardened steel / cast steel	< 60 HRC	1.1730, 1.2379, 1.2358, 1.2767, 1.4112, ASP 2012
	H2.2	Hardened steel / cast steel	< 65 HRC	1.2379, 1.2363, 1.2436, 1.2842, ASP 2005, Vanadis 23
	H2.3	Hardened steel / cast steel	< 68 HRC	ASP 2017, ASP 2023, Vanadis 30, Vanadis 60
H3.1	Wear-resistant cast / chill casting, GJN			

* If the alloy parts Cr, Mo, Ni, V, W are in total > 8%, select the next highest BECK machining group.

The specialist for multi-bladed reamers
and counterboring tools

High-performance reamers with internal coolant supply
in a monoblock design and as modular system

Machine reamers without internal coolant supply
in accordance with DIN or similar to DIN

Hand reamers and taper reamers

Boring tools

Countersinks / counterbores / deburring tools

